

DEPARTMENT OF PUBLIC SERVICE  
ENGINEERING DIVISION

PROJECT SPECIFICATIONS

for

**2021 SANITARY AND STORM SEWER REPAIRS**

Kevin Brubaker  
Safety-Service Director

John Schneider, P.E.  
City Engineer

Signature: \_\_\_\_\_

Date: \_\_\_\_\_

## TABLE OF CONTENTS

	PAGE
Invitation to Bid	3-4
Instructions to Bidders	5-16
Agreement Form	17-26
Notice to Commence Work	27
Finance Director's Certification Form	28
Resolution of Directors	29
Bid Form	30-35
Bid Guaranty and Contract Bond	36
Consent of Surety Form	37
Bidder's Insurance Agent's Affidavit Form	38
Bidder's Insurance Certificate	39
Bidder's Tax Affidavit Form	40
Bidder's Affidavit Form	41
Bidder's Qualification Information	42
Supplementary Conditions	43-44
City Equal Employment Opportunity	45-46
City Affirmative Action Information Sheet	47
Table 1	48
Specifications dated May 2021	49-56
Drawing 1-604R, Sanitary Sewer Repairs Method of Measurement (Rev. 02-04-2014).....	Attached
Examples.....	Attached
State of Ohio - Prevailing Wage Rates.....	Attached
Standard General Conditions (EJCDC C-700) .....	Attached
ODOT Construction and Material Specifications dated January 1, 2019 (May be examined online at )	

## INVITATION TO BID

Sealed bids for a unit price contract will be received by the CITY OF ELYRIA, OHIO until 2:00 PM local time on **Thursday, June 3, 2021** for the project known as:

### **2021 SANITARY AND STORM SEWER REPAIRS**

The bids are to be delivered to the OFFICE OF THE SAFETY-SERVICE DIRECTOR, ELYRIA CITY HALL, 131 COURT STREET, ELYRIA, OHIO 44035. All bids received will then be opened and read at a public bid opening meeting.

**DESCRIPTION OF WORK:** The Contractor shall furnish all labor, equipment, supplies, and supervision of labors necessary to complete the work in response to notification that a sewer problem has been located. This project includes: excavation at various spot locations to replace sections of sewer pipe of various sizes, or to make other repairs to the sewer system and restoration of various items in the tree lawn or pavement areas. The amount of work will vary as needed to repair the various sewers. Based on previous contracts and budget, the estimated quantity of mainline trench excavation of various depths included in the proposal form totals 220 linear feet. All work shall be carried out and completed as specified in the SPECIFICATION "Sanitary Sewer System Repairs and Storm Sewer System Repair", current version.

**BIDDING DOCUMENTS:** The plans, specifications, and all bidding forms may be examined at the City of Elyria Website, <http://www.cityofelyria.org/bids-requests/>, go to "Current Bids". Bidders SHALL request the electronic copy of the bid package by sending their request to [kmckillips@cityofelyria.org](mailto:kmckillips@cityofelyria.org). Due to current COVID-19 orders, no hard copy of the bid documents will be made available for review.

**PRE-BID MEETING:** There will be no pre-bid meeting for this project.

**BID SECURITY:** The bid must be accompanied by a bid guaranty. The bid guaranty must meet all requirements of Section 153.54 of the ORC and the Instructions to Bidders.

**BUY OHIO:** All contractors and subcontractors involved with the project will, to the extent practicable, use Ohio products, materials, services, and labor in the implementation of this project.

**COMPLETION TIME:** The contractor will have until December 31, 2022 to complete the Work.

**PREVAILING WAGES:** The contractor and any subcontractor must comply with the prevailing wage rate requirements on public improvements in Lorain County and the City of Elyria, Ohio, as determined by the Ohio Department of Commerce, Division of Industrial Compliance and Labor, Bureau of Wage and Hour Administration (614) 644-2239. A complete listing of prevailing wage rates on public improvements in Lorain County may be obtained from the City of Elyria Engineer's Office at (440) 326-1444 or at <https://ohio.gov/wps/portal/gov/site/jobs/resources/prevailing-wage>. **Please note it is the Contractor's responsibility to know the prevailing wage rates on public improvements in Lorain County.**

**COMPLIANCE WITH ALL LAWS:** All work shall be carried out in compliance with all federal, state and local laws, rules and regulations that apply to the work. Any project specification item in conflict with a federal, state, or local law, rule or regulation shall be void.

**AFFIRMATIVE ACTION:** All bidders must comply with the provisions of Chapter 167 of the Elyria Codified Ordinances as amended. Bidders must be pre-certified or submit an acceptable Affirmative Action Plan with the bid submission.. No contract will be awarded unless an acceptable Affirmative Action Plan is reviewed by the EEO Office, approved and incorporated into the contract. Each bidder must complete and sign the Elyria Equal Opportunity Clause, which is included with the specifications. The project specifications provides further details on State EEO and Affirmative Action requirements.

**PROPOSAL FORMS:** No proposal will be considered unless it is made on the blanks furnished by the City. No bidder shall take any exception to any requirement of the specifications. Each proposal must contain the full name of the party or parties submitting the proposal and all persons interested therein. Each bidder may submit evidence of its experiences on projects of similar size and complexity.

**AWARD OF CONTRACT:** The City reserves the right to waive any technicalities, informalities or to reject any or all bids received, and to accept any bid with any combination of alternates which is deemed most favorable to the City of Elyria, Ohio at the time and under the conditions stipulated in the project documents.

Published by order of:  
Frank Whitfield, Mayor

Chronicle-Telegram: May 19, 2021; May 26, 2021

## INSTRUCTIONS TO BIDDERS

### 1. ORDINANCE

- 1.1 The bids for this project, **2021 SANITARY AND STORM SEWER REPAIRS**, are being taken in accordance with Ordinance No. 2021-82 passed by the Elyria City Council on Monday, May 4, 2021.

### 2. DEFINED TERMS

- 2.1 Additional terms used in these Instructions to Bidders are defined as follows:

**SUCCESSFUL BIDDER** - the lowest, responsible, and responsive bidder to whom the City (on the basis of the City's evaluation as hereinafter provided) makes an award.

**UNDERGROUND FACILITIES** - all pipes, conduits, ducts, cables, fiber optic cables, wires, service connections, manholes, closeouts, valves, vaults, pull boxes, tanks, tunnels, culverts or other such facilities or attachments, and encasements containing such facilities privately or publicly owned which have been installed underground to furnish any of the following services or materials: electricity, gas, steam, liquid petroleum products, street lighting, telephone or other communications, cable television, sewage and drainage removal, traffic or other control systems, or water.

**WORK** - the entire completed construction or the various separately identifiable parts thereof required to be furnished under the contract documents. Work includes and is the result of performing or furnishing labor and furnishing and incorporating materials and equipment into the construction, and performing or furnishing services and furnishing documents, all as required by the contract documents.

### 3. COPIES OF BIDDING DOCUMENTS

- 3.1 Complete sets of the bidding documents may be purchased from the Office of the City Engineer for the payment of the fee stated in the Invitation to Bid. No refund will be made for returned documents.
- 3.2 Complete sets of bidding documents must be used in preparing bids; the City does not assume any responsibility for errors or misinterpretations resulting from the use of incomplete set of bidding documents.
- 3.3 The City in making copies of the bidding documents available on the above terms does so only for the purpose of obtaining bids for the work and does not confer a license or grant permission for any other use of the bidding documents.

**4. QUALIFICATIONS OF BIDDERS**

- 4.1 To demonstrate qualifications to perform the work, each bidder must be prepared to submit within five (5) days after the bid opening, upon the City's request detailed written evidence such as financial data, previous experience, present commitments and other such data as may be needed to demonstrate the bidders qualifications.
- 4.2 Each bidder must be qualified to do business in the State of Ohio, or must obtain such qualification prior to award of the contract by the City.

**5. EXAMINATION OF CONTRACT DOCUMENTS AND SITE**

- 5.1 It is the responsibility of each bidder before submitting a bid;
  - 5.1.1 To examine thoroughly the contract documents and other related data identified in the bidding documents;
  - 5.1.2 To visit the site to become familiar with and satisfy bidder as to the general, local and site conditions that may affect cost, progress, performance or the furnishing of the work;
  - 5.1.3 To consider federal, state and local laws and regulations that may affect cost, progress, performance, or the furnishing of the work;
  - 5.1.4 To study and carefully correlate bidders knowledge and observations with the contract documents, and other related data; and
  - 5.1.5 To promptly notify the City Engineer of all conflicts, errors, ambiguities or discrepancies which bidder has discovered in or between the contract documents and other related documents or observations.
  - 5.1.6 To evaluate the condition, layout and nature of the project site and surrounding area;
  - 5.1.7 To consider the availability and cost of labor;
  - 5.1.8 To consider the availability and cost of materials, supplies and equipment;
  - 5.1.9 To consider the cost of temporary utilities required in the bid;
  - 5.1.10 To consider the cost of any permit or license required by a local or regional authority having jurisdiction over the project;
  - 5.1.11 To consider the generally prevailing climatic conditions; and
  - 5.1.12 To evaluate conditions bearing upon transportation, disposal, handling, and storage of materials.

- 5.2 Information and data shown or indicated in the contract documents with respect to existing underground facilities at or contiguous to the site is based upon information and data furnished to the City Engineer by the owner of such underground facilities or other, and the City does not assume responsibility for the accuracy or completeness thereof.
- 5.3 Any reports of exploration and tests of subsurface conditions at or contiguous to the site which have been utilized by the Engineer in preparation of the contract documents are identified in the Supplementary Conditions. The bidder may rely upon the general accuracy of the "technical data" contained in such report but not upon other data, interpretations, opinions or information contained in such reports or otherwise related to the subsurface conditions at the site, nor upon the completeness thereof for the purpose of bidding or constructing the project.
- 5.4 The City may have record drawings of previous projects constructed in the past, in part or all of the site where this project is to be constructed. These drawings may be examined by the bidder.
- 5.5 The bidder may purchase copies of the reports noted in Section 5.3 and of the drawings noted in Section 5.4 for the cost of reproduction as established by City Ordinance. Those reports and drawings are not part of the contract documents. The bidder is responsible for any interpretation or conclusion drawn from any technical data, opinions or other information contained in or developed from such reports or drawings.
- 5.6 Before submitting a bid each bidder will be responsible to obtain such additional or supplementary examinations, investigations, explorations, tests, studies, and data concerning conditions (surface, subsurface, and underground facilities) at or contiguous to the site or otherwise which may affect cost, progress, performance, or furnishing the work, or which relates to any aspect of the means, methods, techniques, sequences, or procedure of construction to be selected and employed by bidder and all safety precautions and programs incidental thereto or which bidder deems necessary to determine its bid for the performing and furnishing the work in accordance with time, price, and other terms and conditions of the contract documents.
- 5.7 On request, the City will grant permission to each potential bidder, access to the site (by issuing a no fee excavation permit, except a fee will be required if pavement is to be cut) to conduct such examination, investigation, exploration, tests and studies as each bidder deems necessary for submission of a bid. Bidders must fill all test holes and clean up and restore the site to its former condition upon completion of such explorations, investigation, tests and studies.
- 5.8 The general nature of any work scheduled to be performed at the project site by the City, or by another prime contractor working for the City, and by any utility (if known by the City) that relates to the work for which a bid is to be submitted, is included as information in the Supplementary Conditions.

- 5.9 The submission of a bid will constitute an incontrovertible representation by bidder that bidder has complied with every requirement of the Article 5, and that without exception the bid is premised upon performing and furnishing the work required by the contract documents and applying the specific means, methods, techniques, sequences or procedures of construction selected by the bidder to complete the project as expressly required by the contract documents, that the bidder has given the City Engineer written notice of all conflicts, errors, ambiguities and discrepancies that bidder has discovered (if any) in the contract documents in time for an addenda to be issued to all plan holders, and that the written resolutions thereof issued by the City Engineer as an addenda is acceptable to the bidder, and that the contract documents are generally sufficient to indicate and convey understanding of all terms and conditions for performing and furnishing the work.

## **6. AVAILABILITY OF LANDS FOR WORK**

- 6.1 The lands upon which the work is to be performed, the right-of-way and easements, and access thereto and other lands designated for use by the contractor in performing the work are identified in the contract documents. All additional lands and access thereto required for temporary construction facilities, construction equipment, or storage of materials and equipment to be incorporated in the work are to be obtained and paid for by the contractor.
- 6.2 All easements and/or right-of-way for permanent structures or permanent changes in existing facilities have been obtained and paid for by the City unless otherwise provided in the Supplementary Conditions.
- 6.3 Any special condition set forth in easements obtained by the City which may affect the performance or furnishing the work, if any, are identified in the Supplementary Conditions.

## **7. INTERPRETATIONS AND ADDENDA**

- 7.1 All questions about the true meaning or intent of the bidding documents are to be directed to the City Engineer, or in his absence to the Acting City Engineer. Interpretations or clarifications considered necessary by the City Engineer in response to such questions will be issued by addenda, either mailed, faxed, emailed or hand delivered to all parties recorded by the City Engineer as having received the bidding documents.
- 7.2 An addendum may also be issued by the City Engineer to modify the bidding documents as deemed advisable by the City.
- 7.3 Any bidder may not rely upon any interpretation of the bidding documents by any means other than a written addendum.

## **8. BID SECURITY**

- 8.1 Each bid must be accompanied by a bid guaranty. The bid guaranty may be either a BID/CONTRACT BOND, BID BOND, CERTIFIED CHECK, CASHIERS CHECK or a

LETTER OF CREDIT. The bid guaranty shall meet all requirements of Section 153.54 of the Ohio Revised Code and any additional requirements stated herein.

- 8.2 Any bond shall be furnished by a surety company licensed to conduct business in the State of Ohio. Any check used as bid security shall be drawn on a solvent bank.
- 8.3 Any BID/CONTRACT BOND submitted shall be for the full amount of the base bid plus the highest combination of additive alternates, if any. The form of the BID/CONTRACT BOND shall be of substantially the same form as provided in Section 153.571 of the Ohio Revised Code and it shall serve as both a bid bond and a contract bond. If stated, the amount of the BID/CONTRACT BOND shall be specified in figures. Specifying the amount of the bond as a percentage or one hundred percent (100%) is not acceptable.
- 8.4 Section 3905.41, Ohio Revised Code, may require that a **Bid/Contract Bond** be countersigned by an Ohio resident agent. It is the bidder's responsibility to determine the applicability of Section 3905.41, Ohio Revised Code.
- 8.5 Any CERTIFIED CHECK, CASHIERS CHECK or a LETTER OF CREDIT submitted shall be made payable to the City of Elyria Ohio, and shall be for an amount of not less than ten percent (10%) of the base bid plus the highest combination of additive alternates, if any. The amount shall be stated in figures. Any CERTIFIED CHECK, CASHIERS CHECK or a LETTER OF CREDIT submitted shall be accompanied by an executed Consent of Surety form. . Any letter of credit shall be revocable only by the City. If the successful bidder used a certified check, cashier's check or letter of credit, it will be returned upon provision of the **Contract Bond** required by Section 153.54, Ohio Revised Code.
- 8.6 In case a bidder, to whom a contract is awarded, fails to execute the contract within ten (10) days after notice of award is delivered in writing to the bidder, or in case a bidder fails to secure the contract with an acceptable performance bond and payments bond (each in the full amount of the contract) and execute the contract within ten (10) days after notice of the award is delivered in writing to the bidder, the bidder shall be considered as refusing the contract and shall forfeit their bid security in accordance with provisions of Section 153.54 of the Ohio Revised Code.
- 8.7 The bid security from each bidder may be held by the City for up to sixty (60) days. The bid security will be returned to the unsuccessful bidders after the contract has been signed and secured as provided herein above by the successful bidder.

## 9. **CONTRACT TIME**

- 9.1 The number of days within which, or the date by which, the work is to be substantially completed and also completed and ready for a pre-final payment, are set forth in the Invitation to Bidders and will be set forth in the Agreement Form.

**10. LIQUIDATED DAMAGES**

10.1 Provisions for liquidated damages, if any, are set forth in the Agreement Form.

**11. SUBSTITUTE AND "OR-EQUAL" ITEMS**

11.1 The drawings or specifications may make a reference to a specific manufacturer's make or model identification for a material or item of equipment. The materials and equipment described in this way, by a manufacturer's brand name, establishes a standard of required type, function, quality, expected life to be met by any proposed substitute or "or-equal" item. Such reference to a name shall be considered as requiring the contractor to furnish either that product or a substitute proposed by the contractor and approved by the City Engineer as an approved equal.

11.2 An application for acceptance will not be considered by the Engineer until after the effective date of the Agreement.

11.3 Each submission by the contractor for review of a substitute shall include the name of the material or equipment for which it is to be substituted and a complete description of the proposed item including drawings, cuts, performance and test data, and any other information necessary for an evaluation.

11.4 The Engineer's review of the substitution will consider the City's normal inventory of repair parts for the specified equipment and the possibility of increased down time for repairs to equipment of a type that repair parts are not in the City's inventory.

**12. BID FORM**

12.1 The Bid Form is included with the bidding documents. This form shall be used by the bidder to submit its bid.

12.2 All blanks on the Bid Form (except the signature line) must be completed by printing in black ink or by typewriter. **No white-out may be used on the Bid Form.**

12.3 Discrepancies between the sum of the labor unit price in the bid and/or the material unit price in the bid for an item will be resolved by using the total unit price in the bid stated by the bidder. Discrepancies between the amount in figures and the amount in words for the total unit bid price for an item will be resolved by using the amount stated in words. The Bid Price for each item shall be the sum of the total unit prices times the estimated quantity. Discrepancies between the multiplication of the estimated quantity of an item on the proposal and the total unit price stated by the bidder will be resolved by using the total unit price stated by the bidder and the estimated quantity.

12.4 Bids by corporations must be executed by a corporate officer accompanied by evidence of authority to sign. The corporate seal must be affixed and attested by the secretary or an assistant secretary.

- 12.5 Bids by a partnership must be executed in the partnership name and signed by a partner, whose title must be shown below the signature.
- 12.6 The bid shall contain an acknowledgment of receipt of all addenda.
- 12.7 The address and telephone number for communication regarding the bid must be shown.
- 12.8 An out-of-state corporation must provide evidence of authority to conduct business in the State of Ohio.
- 12.9 The unit bid price stated in the bid form shall be the full price for completion of one unit of the item which unit price shall include all payments by the City to the contractor for all labor, material, equipment, supervision, and overhead required to complete that unit of an item.
- 12.10 The cost of completing all work specified in the drawings and in the specifications, in accordance with the contract documents, shall be included by the bidder in the pay items listed on the Bid Form.

**13. PREVAILING WAGE RATES**

- 13.1 The Contractor agrees to pay wages equal to or exceeding the minimum wage rates as determined by the Ohio Department of Commerce, as per the rates attached hereto or as amended by the Ohio Department of Commerce during the life of this Agreement. The Contractor agrees to require all subcontractors, if any, to pay wages equal to or exceeding the minimum wage rates as determined by the Ohio Department of Commerce. The contractor and any subcontractor must comply with the prevailing wage rate requirements on public improvements in Lorain County and the City of Elyria, Ohio, as determined by the Ohio Department of Commerce, Division of Industrial Compliance and Labor, Bureau of Wage and Hour Administration (614) 644-2239.

**14. SUBMISSION OF BIDS**

- 14.1 Bids shall be submitted at the time and place indicated in the Invitation to Bidders and shall be bound with the other bidding documents, and enclosed in an opaque sealed envelope marked "**BID ENCLOSED**" for project (by name) plus the name and address of the bidder.
- 14.2 If the bid is sent through the mail or delivered by another delivery system, the sealed bid envelope shall be enclosed in a separate envelope with the notation "**BID ENCLOSED**" on the face of the delivery envelope. Bids received, if any, after the deadline for delivery of bids, will be returned unopened.

**15. NO MODIFICATION OF BIDS**

- 15.1 After submission of a bid to the City, no modification of the bid may be made by the bidder.

**16. WITHDRAWAL OF BIDS**

- 16.1 After submission of a bid to the City, and at any time before the deadline for bid submission, the bidder may withdraw its bid by giving a duly signed written notice requesting to withdraw the bid to the City. Thereafter, that bidder will be disqualified from further bidding on the work, including any re-bid held by the City.

**17. OPENING OF BIDS**

- 17.1 All bids received will be opened and (unless obviously non-responsive) read aloud publicly at the place where the bids are to be submitted. A summary of the prices bid will be mailed to all bidders after a tabulation of the bids is completed by the Engineer.

**18. BIDS TO REMAIN SUBJECT TO ACCEPTANCE**

- 18.1 All bids will remain subject to acceptance for sixty (60) days after the day of the bid opening, but the City may, in its sole discretion, release the bid and return the bid security prior to the end of the sixty (60) day period.

**19. AWARD OF CONTRACT**

- 19.1 The City reserves the right to reject any or all bids, including without limitation, the rights to reject any or all nonconforming, nonresponsive, unbalanced or conditional bids, and to reject the bid of any bidder if the City believes that it would not be in the best interest of the City to make an award to that bidder, whether because the bid is not responsive or the bidder is unqualified or of doubtful financial ability or fail to meet any other pertinent standard or criteria established by the City.
- 19.2 In evaluating the bids to determine the lowest and best bid, the City will consider the qualification of the bidders, whether or not the bids comply with the prescribed requirements, and such alternates, unit prices and other data, as may have been submitted with the bid or as may be requested per the contract documents before the award is made by the City.
- 19.3 The City may consider the qualifications and experience of the subcontractors, suppliers, and other persons and organizations proposed for those portions of the work as to which the identity of subcontractors, suppliers, and other persons and organizations must be submitted as provided in the Supplementary Conditions. The City may consider also the operating cost, maintenance requirements, performance data and guaranties of major items of materials and equipment proposed for incorporation in the work when such data is required to be submitted prior to the award of the work.
- 19.4 The City may conduct such investigations as the City deems necessary to assist in the evaluation of any bid and to establish the responsibility, qualifications and financial ability of the bidders, proposed subcontractors, suppliers, and other persons and organizations to

perform and furnish the work in accordance with the contract documents to the City's satisfaction within the prescribed time.

- 19.5 If the contract is to be awarded, it will be awarded to the bidder whose evaluation by the City indicates to the City that the award will be in the best interest of the City.
- 19.6 If the contract is to be awarded, the City will give the successful bidder a Notice of Award within sixty (60) days after the day of the bid opening, unless the bidder grants a time extension to the City.

**20. SIGNING OF AGREEMENT**

- 20.1 When the City gives a written Notice of Award to the successful bidder, it will be accompanied by the required number of the unsigned counterparts of the Agreement. Within ten (10) days thereafter the contractor shall sign the Agreement and deliver all copies to the City Engineer. The City will then execute the Agreement, and the Finance Director's Certification of Funds, and will deliver one (1) fully executed Agreement to the contractor with the Notice to Commence Work. One copy of the Agreement and attached documents will be sent to the local agent of the contractor's surety.

**21. CONTRACT SECURITY**

- 21.1 When the successful bidder delivers the executed Agreement to the City, it must be accompanied by the required performance and payment bonds, unless the bond submitted with the bid was a BID/CONTRACT BOND which will serve as the required contract security.

**22. SALES TAXES**

- 22.1 The City is exempt from Ohio state sales and use taxes on the materials and equipment to be incorporated into the work. Said taxes shall not be included in the bid price. The contractor shall contact the Finance Director's Office for completion of the tax exempt forms for the project.

**23. PROGRESS PAYMENTS AND RETAINER**

- 23.1 Progress payments may be made to a Contractor before the work is completed. Progress payments so paid to a Contractor shall be based on actual measurements of labor and materials furnished, including materials delivered, under the contract to the date of estimate. The amount of a progress payment shall be determined by subtracting from the value of the portion of the work completed and materials furnished to the date of the estimate a retainer of ten percent (10%) and the sum of all previous progress payments.
- 23.2 Thirty (30) days after substantial completion of the work under the contract, and upon approval of the work by the Engineer, the ten percent (10%) retainage may be reduced to five percent (5%).

- 23.2 The Contractor shall be responsible for full guaranty of work for complete one year from the date of final completion of the contract. No retainer shall be subject to interest payments to the Contractor nor required to be deposited with an escrow agent who will pay interest to the Contractor.

## **24 CONTRACTOR LICENSES**

- 24.1 The Contractor and all Subcontractors shall obtain, maintain and renew the necessary licenses as required by the City of Elyria Building Department to complete the Work. The Contractor shall secure all credentials and pay for all necessary fees associated with obtaining these licenses. Fees shall be included in the price of the contract and no additional payment will be made to the Contractor for reimbursement of fees. Licenses shall be obtained prior to initiating any construction activity associated with that particular license.

## **25. EQUAL EMPLOYMENT OPPORTUNITY**

- 25.1 In addition to the City of Elyria, Ohio, Codified Ordinance Chapter 167, the contractor shall, and all subcontractors working on the project shall, comply with the equal employment requirements for the utilization of minorities and females pursuant to Chapter 123 of the Ohio Administrative Code, the Governor's Executive Order of 1972, and the Governor's Executive Order 84-9.

## **26. WARRANTY OF WORKMANSHIP AND MATERIALS**

- 26.1 The Successful Bidder shall warrant that all labor furnished under this project shall be competent to perform the tasks undertaken, that the product of such labor shall yield only first-class results, that all material and equipment provided shall be new and of high quality, that the completed work will be complete, of high quality, without defects, and that all work complies with the requirements of this project.
- 26.2 The duration of the Bidders warranty, including equipment and labor, shall be one (1) year from the date of Substantial Completion or upon written acceptance notice date by the City for individual pieces of equipment.

## **27 STORMWATER BEST MANAGEMENT PRACTICES**

- 27.1 The Contractor and all Subcontractors shall consider and implement any and all storm water best management practices (BMPs) as per City of Elyria Codified Ordinance Chapter 960 "Storm Water Management" and as per the Ohio Department of Natural Resources in the most recent version of the Rainwater and Land Development manual for construction site runoff and post-construction site runoff as required to minimize, reduce and/or eliminate the discharge of contaminated or sediment-laden storm water from the construction site. All existing and proposed outlets and drainage courses shall be protected.

The Contractor shall develop and submit a plan for approval if the construction site is over one acre. Weekly site inspections, including all inspections within 24 hours after a rain event,

shall be the responsibility of the contractor. Completed and signed inspection forms shall be submitted to the Engineer within 48 working hours after the completion of the inspection. Maintenance of all BMPs shall be the responsibility of the contractor. The contractor and all of its subcontractors shall comply with all other storm water best requirements as specified in the specifications, documents, Storm Water Pollution Prevention Plans and/or drawings for this project. Cost for this work shall be included in 1) the individual unit price bid for Storm Water Pollution Prevention Plan (SWPPP), 2) the separate line items as applicable, or 3) the total lump sum base bid for the project.

## **28. SUBCONTRACTOR QUALIFICATIONS**

- 28.1 Within five (5) days after the bid opening and prior to Award of Contract, the Successful Bidder shall supply to the City a list of subcontractors that it intends to use for the project, if not included with the original bid submittal. The City, at its sole discretion, may request that a subcontractor be replaced or not used. If the Successful Bidder refuses to replace this subcontractor, the City reserves the right to award the contract to the next lowest and best bidder deemed most qualified to perform the Work. The City may request references for any subcontractor. If the Successful Bidder proposes to change a subcontractor at any time after submittal of the original list of subcontractors, including during construction, the new subcontractor shall be approved by the City prior to that subcontractor performing any work on the project.

## **29. CLAIM MANAGEMENT PROCESS**

- 29.1 The City of Elyria will utilize the following procedure that is fair to all parties, to resolve disputes administratively, and expedite dispute resolutions.

1. The Claim Management process for this project will follow the guidelines shown below:
  - a. Contractor's claims involving minor quantity adjustments can be approved by the Chief Construction Inspector in the field. Any necessary quantity adjustments that are agreed upon are noted by the Chief Construction Inspector and addressed in a future Change Order. These claims typically result from minor plan calculations errors, actual field measurements and/or proof of material deliveries. Contractor shall provide necessary documents to in support.
  - b. If the Contractor's claim cannot be resolved by the Chief Construction Inspector, then the claim and all supporting documentation will be forwarded to the Construction Project Engineer (CPE) for review. This review typically takes three (3) business days to complete.
  - c. If the Contractor's claim cannot be resolved by the Construction Project Engineer, then the claim and all supporting documentation will be forwarded to the City Engineer for review. This review takes typically seven (7) business days to complete.
  - d. If the Contractor's claim cannot be resolved by the City Engineer, then the claim and all supporting documentation will be forwarded to the City Law Director for resolution through remediation or through Court action.

Please note that any claim resolution that is achieved during this process that either increases or decreases the total contract amount, or modifies the Contractor's contractual completion date must be approved by the City Engineer through Change Order process to be valid. The Change Order is approved and signed by the Mayor, City of Elyria.

2. When analyzing a Contractor's claim, the following items will be considered:
  - a. Was the claim filed in a timely manner and was the City given proper notice of the claim by the contractor?
  - b. The Contractor's justification of the claim.
  - c. Do the project plans and specifications address the elements of the claim?
  - d. Do the contract documents address the elements of the Contractor's claim?
  - e. Determination of actual field conditions giving rise to the claim.
  - f. Identify each specific claim issue. Identify the position of both sides on each issue.
  - g. Identify responsibility. If the claim is delay related, is it excusable vs. non-excusable, compensable or is there an issue of concurrent delay?
  - h. The actual impact of the delay on the contractor.
  - i. Did the contractor inspect the project site and get familiar with all conditions prior to submitting his bid?

**AGREEMENT FORM**

**AGREEMENT  
BY AND BETWEEN  
THE CITY OF ELYRIA  
AND**

---

**CONTRACT NO. 21-09-E**

This Agreement is made and entered into, effective upon full execution by all parties, by and between the City of Elyria, Ohio, an Ohio municipal corporation with offices located at 131 Court St., Elyria, Ohio 44035 (the “City”) and \_\_\_\_\_, an Ohio entity with offices located at \_\_\_\_\_, Ohio 44\_\_\_\_ (the “Contractor”).

WHEREAS, this Agreement was authorized by Ordinance No. 2021-82, which was passed by the Elyria City Council on May 4, 2021; and

WHEREAS, the City desires to enter into an agreement for \_\_\_\_\_ services (the “Agreement” or “Contract”); and

WHEREAS, the Contractor has submitted a bid in response to the City’s request for bid proposals; and

WHEREAS, the City has determined that the Contractor has the experience and resources to complete the work as contemplated by this Agreement.

NOW, THEREFORE, in consideration of the mutual covenants contained herein and other good and valuable consideration, the receipt and sufficiency of which is hereby acknowledged, the City and the Contractor agree as follows:

**ARTICLE 1 – WORK**

The Contractor shall furnish all labor, equipment, supplies, and supervision of labors necessary to complete the work, which is the subject of this Agreement (the “Work”). The Work will involve the construction of \_\_\_\_\_. The project location is \_\_\_\_\_. Construction documents were prepared by \_\_\_\_\_ and the Office of the Elyria City Engineer.

The City’s request for bid proposals (attached as Exhibit “A”) and Contractor’s proposal (attached as Exhibit “B”) are incorporated by reference as if fully rewritten herein. In the event that a discrepancy exists between the terms of Exhibits A and B, the terms of Exhibit A will be controlling and binding. In the event that a discrepancy exists between the terms of the Exhibits and this Agreement, the terms of this Agreement will be controlling and binding.

**ARTICLE 2 - ENGINEER TO BE CITY'S REPRESENTATIVE**

The services of the Contractor shall be carried out under the authority for contract administration of the Mayor and Safety-Service Director of the City, who is designating the City Engineer as the person who, as the City's representative, will administer the contract, undertake and assume all duties and responsibilities, and will have the authority and rights assigned to the Engineer under the specifications for this work.

**ARTICLE 3 - CONTRACT PERFORMANCE**

**COMPLETION TIME: Construction of this project shall begin at the discretion of the contractor but must be completed no later than \_\_\_\_\_, 20\_\_.**

**ARTICLE 4 - LIQUIDATED DAMAGES**

The City and the Contractor recognize that time is of the essence in this agreement, and that the City will suffer financial loss (including but not limited to incidental and consequential damages) if the Work is not carried out within the time specified in Article 3 herein. Both the City and the Contractor recognize the impossibility of calculating the actual loss suffered by the City if the Work is not substantially completed within the specified time. Accordingly, instead of requiring any such proof, the City and the Contractor agree that as liquidated damages for delay (but not as a penalty) the Contractor shall pay the City the sum of five hundred dollars (\$500.00) for each calendar day that expires after the time specified in Article 3 herein for completing the work assigned, unless the City grants a time extension for good reason not under the control of the Contractor. In addition to the foregoing, Contractor agrees to pay for the cost of any additional inspection services that the City requires as a result of delays.

**ARTICLE 5 - CONTRACT AMOUNT**

The City shall pay the Contractor for performance of the Work, in accordance with the contract documents, a total amount of, which shall not exceed, \_\_\_\_\_ Dollars and \_\_\_\_\_ Cents (\$\_\_\_\_\_).

**The Contractor agrees that no extra work will require any extra or additional payments by the City, unless the extra work is authorized in writing by the City's Mayor before the extra work is performed.**

**ARTICLE 6 - PAYMENT PROCEDURES**

The Contractor agrees to promptly (by the 5th of each month), but not more frequently than once every thirty (30) days, submit an original invoice with one (1) copy and the required estimate computations with required certifications to the Engineer. The City will make progress payments on or about the 26<sup>th</sup> day of each month.

Prior to substantial completion, progress payments will be in an amount equal to ninety percent (90%) of the Work completed and ninety percent (90%) of the materials and equipment delivered to

the project site, but not yet incorporated into the Work, less in each case, the aggregate of all payments previously made. No retainer shall be subject to interest payments to the Contractor nor required to be deposited with an escrow agent who will pay interest to the Contractor.

**Acceptance of the Work, Pre-Final Payment and Final Payment:** Upon final completion and acceptance of the work by the City in accordance with E.C.O. 143.06, the City shall pay the Contractor all funds due the Contractor, except for the five percent (5%) retainer per Section 22 of the Instructions to Bidders. The five percent (5%) retainer shall be paid by the City to the Contractor, after completion of all work and all punch list items. If defects in the Work are found during the one (1) year period after final completion, the defects are to be corrected by the Contractor. The corrected work shall be guaranteed for a period of one (1) year by the Contractor. After satisfactory completion of all work and all punch list items, the five percent (5%) retainer or any payment withheld for other purpose may be released.

## **ARTICLE 7 - CONTRACTOR'S REPRESENTATIONS**

The Contractor acknowledges that it has taken the steps reasonably necessary to ascertain the nature and the location of the Work to be performed, and that it has investigated and satisfied itself as to the general and local conditions which can affect the Work, its cost, including but not limited to (1) the cost of purchasing, transportation, handling and storage of materials and supplies, (2) the availability of labor and cost, (3) the uncertainties of weather or similar physical conditions, including the time of year the project is to be constructed, (4) all other physical conditions which can impact the cost of doing Work, (5) the character of the equipment and facilities needed to prepare to do the work and to carry out the work to be performed, considering the limited work area, and the access to the site, (6) the cost of the Contractor's overhead, (7) the cost of providing worker supervision and management, (8) the cost of providing insurance, bonds, and related expenses.

The Contractor also acknowledges that it has had sufficient time during the bidding of the project to review all contract documents, and to make all investigations necessary to reasonably ascertain the cost of doing the Work. Further, the Contractor has correlated the results of observations, examination, investigations, and review of local labor conditions with the terms and conditions of all of the contract documents, including the addenda listed on the Contractor's Bid Form, in determining the price bid for the Work. The Contractor acknowledges that the City assumes no responsibility for any understanding reached or representations made concerning conditions which can affect the Work, by any of its officers, employees, or agents before execution of this Agreement, unless that understanding or representation is expressly stated in the contract documents which are a part of the Agreement.

## **ARTICLE 8 – INDEMNIFICATION**

Contractor shall indemnify, defend and hold harmless the City, its elected officials, employees, representatives and agents (the “Indemnified Parties”) from and against any and all loss, cost, expense, damage, injury, liability, claim, demand, penalty or cause of action (including attorneys' fees) directly or indirectly arising out of, resulting from or related to (in whole or in part), (1) the Work performed hereunder, (2) the contract or (3) an act or omission of Contractor, a Subcontractor or any individual partnership or joint venture or corporation (a) directly or indirectly employed by

Contractor or a Subcontractor or (b) for whose acts or omissions Contractor or a Subcontractor may be liable. Contractor shall promptly advise the City in writing of any action, administrative or legal proceeding or investigation as to which this indemnification may apply, and Contractor, at Contractor's expense shall assume on behalf of the City, and conduct with due diligence and in good faith, the defense with counsel satisfactory to the City, provided, that the City shall have the right to be represented therein by advisory counsel of its own selection and at its own expense; and provided further, that if the defendants in any such action include both Contractor and the City, and the City shall have reasonably concluded that there may be legal defenses available to the City which are different from or additional to, or inconsistent with those available to Contractor, the City shall have the right to select separate counsel to participate in a defense of such action on its own behalf at Contractor's expense. In the event of failure by Contractor to fully perform in accordance with this indemnification, the City, at its option, and without relieving Contractor of its obligations hereunder may so perform, but all costs and expenses so incurred by the City in that event shall be reimbursed by Contractor to the City, together with interest on the same from the day any such expense was paid by the City until reimbursed by Contractor at the rate of interest provided to be paid on judgments, by the law of the State of Ohio. The obligations of Contractor under this Section shall survive the expiration of the Contract.

In claims against any of the Indemnified Parties by an employee of the Contractor, a Subcontractor, anyone directly or indirectly employed by them or anyone for whose acts or omissions they may be liable, the indemnification obligation under this Section shall not be limited by a limitation on the amount or type of damages, compensation or benefits payable by or for the Contractor or Subcontractor under workers' compensations acts, disability benefits acts, or other employee benefit acts.

The Contractor acknowledges that, as a political subdivision of the State of Ohio, the City does not indemnify any person or entity. The Contractor agrees that no provision of this Agreement or any other agreement between the Contractor and the City may be interpreted to obligate the City to indemnify or defend the Contractor or any other party.

**ARTICLE 9 - CONTRACT DOCUMENTS**

This Agreement and accompanying documents, including the Bid Form, Unit Price Schedule, Instructions to Bidders, Invitation to Bid, all Addenda listed on the Contractors Bid Form, the General Conditions, State Prevailing Wages and Technical Specifications as prepared by the City Engineer's Office, and all attachments submitted by the Contractor with its Bid Form, are made a part of the Agreement hereto as if the contents of those contract documents were fully rewritten herein. The City and the Contractor agree that there are no oral or written representations, understandings or agreements relating to this Agreement which are not fully expressed herein. No modification, change or amendment hereof shall be valid unless such is in writing and signed by the authorized representative of the party against which such modification, change or amendment is sought to be enforced.

**ARTICLE 10 - INSURANCE**

10.1 Insurance Coverage Requirements. Contractor agrees to procure and maintain during the term of

this Agreement insurance in the types and amounts shown below.

- a) Worker's Compensation in full compliance with the requirements of the State of Ohio.
- b) SEE REQUEST FOR BID PROPOSALS FOR SPECIFIC INSURANCE REQUIREMENTS.

All insurance shall be exclusive of defense costs whenever possible.

#### 10.2 Insurance Coverage Terms and Conditions.

- a) The insurance policies of the Contractor, required for this Agreement, shall:
  - (i) Name the "City of Elyria, Ohio" as an Additional Insured. This does not apply to Worker's Compensation and Professional Liability.
  - (ii) Contain a waiver of subrogation provision wherein the insurer(s) waives all rights of recovery against the City; and
  - (iii) Be primary and not in excess or contingent on any other basis; and
- b) The insurance required for this Agreement shall be provided by insurance carrier(s) licensed to transact business and write insurance in the state(s) where operations are performed and shall carry a minimum A.M. Best's rating of A- VII or above.
- c) The terms of this Agreement shall be controlling and shall not be limited by any insurance policy provision.
- d) High-risk activities may require higher insurance limits.
- e) These insurance provisions shall not affect or limit the liability of the Contractor stated elsewhere in this Agreement or as provided by law.
- f) The Contractor shall require any and all of its subcontractors to procure, maintain, and pay premiums for the insurance coverages and limits of liability outlined above with respect to products, services, work and/or operations performed in connection with this Agreement.
- g) The City reserves the right to require insurance coverages in various amounts or to modify or waive insurance requirements on a case-by-case basis whenever it is determined to be in the best interest of the City.
- h) If the Bid/Proposal specifies the need for higher limits of liability for any applicable insurance provision, the Bid/Proposal specifications shall govern.
- i) Where coverages are made on a claims-made basis, the claims-made retroactive date on the policy shall be prior to the commencement of professional activity related to this Agreement.
- j) The Contractor shall furnish a Worker's Compensation Certificate and Certificate of Insurance evidencing that the insurance coverages required herein are in full force and effect.

Acceptance of a non-conforming certificate of insurance by the City shall not constitute a waiver of any rights of the parties under this Agreement.

k) The Certificate(s) of Insurance evidencing these coverages shall contain the following additional insured and waiver of subrogation language where applicable:

- (i) “City of Elyria, Ohio is an additional insured for purposes of commercial general liability and automobile liability”: and/or
- (ii) “Waiver of subrogation in favor of the City of Elyria.”

l) Any additional insured shall receive at least thirty (30) days’ notice of any cancellation, change reducing the coverage, or refusal to renew, which is adverse to the interest of any additional insured to be affected. The City shall be provided with any notice of non-renewal, regardless of the cost. The same terms apply to any subcontractors to the extent practical.

10.3 Certificate of Insurance. This Agreement is contingent upon, and not valid or binding upon City, until such times as City receives said Certificate of Insurance.

## **ARTICLE 11 - TERMINATION**

11.1 Termination for Default. Either party may terminate this Agreement, in whole or in part, whenever such party determines that the other has failed to satisfactorily fulfill its material obligations and responsibilities hereunder and is unable to cure such failure within a reasonable period of time, not to exceed thirty (30) calendar days. Such termination shall be referred to as “Termination for Default.” If the defaulting party is unable to cure the failure within the specified time period, the party seeking to terminate may, by giving written notice thereof to the defaulting party, terminate this Agreement, in full or in part, as of the date specified in the notice of termination. The Contractor, however, shall be paid for all services and/or materials provided on or prior to the date of termination. Any fees paid in advance shall be returned to the City at a prorated amount.

11.2 Termination for Financial Instability. In the event that the Contractor becomes financially unstable to the point of (i) ceasing to conduct business in the normal course, (ii) making a general assignment for the benefit of creditors, or (iii) suffering or permitting the appointment of a receiver for its business or its assets, or there is a filing by or against the Contractor of a meritorious petition in bankruptcy under any bankruptcy or debtor’s law, the City may, at its option, terminate this Agreement under Section 11.1, the “Termination for Default” clause, by giving written notice thereof.

## **ARTICLE 12 – ASSIGNMENT**

No assignment by a party hereto of any rights under or interests in the Agreement will be binding on another party hereto without the written consent of the party sought to be bound; and specifically but without limitation, moneys that may become due and moneys that are due may not be assigned without such consent (except to the extent that the effect of this restriction may be limited by law),

and unless specifically stated to the contrary in any written consent to an assignment. No assignment will release or discharge the assignor from any duty or responsibility under the contract documents.

**ARTICLE 13 – SAFETY**

The Contractor agrees to comply with Chapter 4121:1-3 of the Ohio Administrative Code entitled “Specific Safety Requirements of the Industrial Commission of Ohio relating to Construction,” effective November 1, 1979 and with the “Federal Occupational Safety and Health Act of 1970 and Code of Federal Regulation, Title 29, Chapter XVII, Part 1926,” and to also comply with all other requirements of law.

**ARTICLE 14 – WARRANTY**

THE CONTRACTOR HEREBY WARRANTS THAT THE SERVICES WILL NOT INFRINGE, MISAPPROPRIATE OR VIOLATE ANY INTELLECTUAL PROPERTY OR ANY OTHER RIGHT OF ANY PERSON OR ENTITY. THE SERVICES WILL BE PERFORMED IN A PROFESSIONAL AND WORKMANLIKE MANNER, CONSISTENT WITH INDUSTRY STANDARDS. THE SERVICES WILL BE PERFORMED IN STRICT ACCORDANCE WITH THE HIGHEST STANDARDS OF CARE, SKILL, DILIGENCE AND PROFESSIONAL COMPETENCE APPLICABLE TO SUPPLIERS/CONTRACTORS ENGAGED IN PROVIDING SIMILAR SERVICES IN THE LORAIN COUNTY AREA. THE CONTRACTOR HAS THE REQUISITE SKILL AND STAFF TO PERFORM THE SERVICES REQUIRED HEREUNDER FULLY, IN A TIMELY AND EFFICIENT MANNER. THE CONTRACTOR WILL PERFORM THE SERVICES IN ACCORDANCE WITH ALL APPLICABLE LAWS.

**ARTICLE 15 - PREVAILING WAGE RATES**

The Contractor agrees to pay wages equal to or exceeding the minimum wage rates as determined by the Ohio Department of Commerce (“ODOC”). The Contractor agrees to require all subcontractors, if any, to pay wages equal to or exceeding the minimum wage rates as determined by the ODOC.

**ARTICLE 16 – SUCCESSORS**

The City and the Contractor each bind themselves, their partners, successors, assigns and legal representatives in respect to all conveniences, agreements and obligations contained in the contract documents.

**ARTICLE 17 - OTHER PROVISIONS**

The Contractor agrees to comply with the requirements of Chapter 167 of the Elyria Codified Ordinances as amended, regarding Affirmative Action and Equal Employment Opportunity. All sections of Chapter 167 as amended on the first date of advertising this project, which are to be a part of any construction or service agreement executed by the City, are included in this Agreement by reference, as if repeated in full herein.

**ARTICLE 18 – GOVERNING LAW**

This Agreement shall be governed by, and shall be construed and enforced in accordance with, the laws of the State of Ohio. The parties agree that any actions regarding this Agreement or the Work performed hereunder shall be brought in the Court of Common Pleas of Lorain County, Ohio. Each party consents to the exclusive jurisdiction of the Court of Common Pleas of Lorain County, Ohio, and hereby agrees not to challenge this Governing Law and Jurisdiction provision, and further agrees not to attempt to remove any legal action outside of Lorain County for any reason.

**ARTICLE 19 – SEVERABILITY**

If any term or provision of this Agreement is deemed by a court of law to be invalid or enforceable, the remainder of this Agreement shall not be affected thereby, and each remaining term or provision of this Agreement shall be valid and enforceable to the fullest extent permitted by law.

**ARTICLE 20 – SURVIVAL OF TERMS**

Termination or expiration of this Contract for any reason shall not release either party from any liabilities or obligations set forth in this Contract which (i) the parties have expressly agreed shall survive any such termination or expiration, or (ii) remain to be performed or by their nature would be intended to be applicable following any such termination or expiration.

**ARTICLE 21 – WAIVER**

No delay or omission by either party in the exercise of any right or power shall impair any such right or power or be construed to be a waiver thereof. A waiver by either of the parties of any of the covenants, conditions or agreements to be performed by the other or any breach thereof shall not be construed to be a waiver of any succeeding breach thereof or of any other covenant, condition or agreement herein contained. No change, waiver or discharge hereof shall be valid unless in writing and signed by an authorized representative of the party against which such change, waiver, or discharge is sought to be enforced.

**ARTICLE 22 – FORCE MAJEURE**

Neither Party shall be in default if its failure to perform any obligation hereunder is caused solely by supervening conditions beyond that Party's reasonable control, including, without limitation, acts of God, civil commotion, strikes, labor disputes, or governmental demands or requirements.

**ARTICLE 23 – INDEPENDENT CONTRACTOR**

It is fully understood and agreed that the Contractor is an independent contractor and is not an agent, servant, or employee of the City. The Contractor declares that it is engaged as an independent business and has complied with all applicable federal, state, and local laws regarding business permits and licenses of any kind, including but not limited to any insurance coverage, workers' compensation, or unemployment compensation that is required in the normal course of business and will assume all responsibility for any federal, state, municipal or other tax liabilities.

**ARTICLE 24 - ANTI-DISCRIMINATION**

Contractor agrees that in its employment of labor, skilled or unskilled, there shall be no discrimination exercised against any person because of race, color, religion, national origin, sex, gender, ancestry, age, disability, sexual orientation, sexual identity, genetic information, military status, or veteran status, and a violation of this term shall be deemed a material breach of this Contract.

**ARTICLE 25 – HEADINGS**

The section headings appearing in this Contract are inserted only as a matter of convenience and in no way define, limit, or describe the scope or extent of such section.

**ARTICLE 26 - COUNTERPARTS**

This Contract may be executed in separate original or facsimile counterparts, each of which shall be deemed an original, and all of which shall be deemed one and the same instrument.

**ARTICLE 27 – OHIO REVISED CODE**

Contractor shall comply with all applicable provisions of Sections 2909.21 to 2909.34 Ohio Revised Code (Ohio Patriot Act) and Sections 3517.13 Ohio Revised Code.

**(THE REMAINDER OF THIS PAGE INTENTIONALLY LEFT BLANK)**

**(SIGNATURE PAGE TO FOLLOW)**

2021 SANITARY AND STORM SEWER REPAIRS

IN WITNESS WHEREOF, this Agreement has been executed in duplicate by the City and the Contractor on the dates below.

**CONTRACTOR NAME**

**THE CITY OF ELYRIA, OHIO**

\_\_\_\_\_  
Signature

\_\_\_\_\_  
Frank Whitfield – Mayor      Date

\_\_\_\_\_  
Print Name

APPROVED AS TO FORM:

\_\_\_\_\_  
Date

\_\_\_\_\_  
Amanda R. Deery, Law Director

\_\_\_\_\_  
Date

**NOTICE TO COMMENCE WORK  
and  
NOTICE TO COMMENCEMENT OF A PUBLIC IMPROVEMENT  
PURSUANT TO REVISED CODE SECTION 1311.252**

State of Ohio

SS

County of Lorain

I, Frank Whitfield, being first duly sworn, say that:

- 1) Affiant is the Mayor of the City of Elyria, Ohio.
- 2) The City of Elyria, Ohio gives this Notice to Commence Work to the Contractor, for the public improvement identified as **2021 SANITARY AND STORM SEWER REPAIRS**.
- 3) The following is the name, address and trade of the principal contractor working on this public improvement:

NAME:  
 ADDRESS:  
 TRADE:  
 DATE OF FIRST EXECUTED CONTRACT:

- 4) The following is the name and address of the surety for the principal contractor:

NAME OF SURETY:  
 ADDRESS OF SURETY:

- 5) For the purpose of serving an affidavit pursuant to Revised Code Section 1311.26, service may be made upon the following representative of the Public Authority:

Mayor Frank Whitfield  
 CITY OF ELYRIA, OHIO  
 131 Court Street  
 Elyria, Ohio 44035

FURTHER AFFIANT SAYETH NAUGHT.

Signature: \_\_\_\_\_

SWORN TO BEFORE ME and subscribed in my presence this \_\_\_\_\_ day of \_\_\_\_\_, 2021.

(SEAL)

Notary Public: \_\_\_\_\_

**AUDITOR'S CERTIFICATION OF FUNDS**

I hereby certify that there is in the Treasury of the City of Elyria, State of Ohio, to the credit of W.W.P.C. Fund, W.W.P.C. Misc. Dept., and not appropriated for any other purpose and/or in the process of collection, as required by law, the sum of \_\_\_\_\_  
\_\_\_\_\_ DOLLARS AND \_\_\_\_\_ CENTS(\$ \_\_\_\_\_) to pay the cost of the attached contract for the 2021 SANITARY AND STORM SEWER REPAIRS in the City of Elyria, Ohio.

Executed this \_\_\_\_\_ day of \_\_\_\_\_, 2021.

\_\_\_\_\_  
Finance Director

Ordinance No.: 2021-82

Passed On: Monday, May 4, 2021

Account No. 640.05.0096.4103

## RESOLUTION OF DIRECTORS

Date \_\_\_\_\_

The Board of Directors of:

\_\_\_\_\_ (Firm Name)

met on the \_\_\_\_\_ day of \_\_\_\_\_ year \_\_\_\_\_.

A motion was made, seconded and passed authorizing

\_\_\_\_\_ (Name), \_\_\_\_\_ (Title)

to sign and submit a bid to the City of Elyria, Ohio, for the:

\_\_\_\_\_ (Name of Project)

and authorizing the same person to enter into a contract with the City of Elyria, Ohio, if the City awards the work to the firm.

By: \_\_\_\_\_, Title: \_\_\_\_\_  
(Signature )

ATTEST:

By: \_\_\_\_\_, Title: \_\_\_\_\_  
(Signature )

NOTE: A similar form with an original signature and a current date (within 12 months) may be used in place of this form. If the form submitted with the bid has photocopy signatures, the form must be replaced with one having original signatures, before the contract is signed.

# BID FORM

## UNIT PRICE CONTRACT

Project: **2021 SANITARY AND STORM SEWER REPAIRS**

THIS BID IS SUBMITTED TO: Mayor Frank Whitfield  
Office of the Safety-Service Director  
City of Elyria, Ohio  
131 Court Street  
Elyria, Ohio 44035

1. The undersigned BIDDER proposes and agrees, if this BID is accepted, to enter into an AGREEMENT with the CITY in the form included in the Contract Documents to complete all WORK as specified or indicated in the CONTRACT DOCUMENTS, for the CONTRACT PRICE, and within the CONTRACT TIME indicated in this Bid, and all in accordance with the CONTRACT DOCUMENTS.
2. BIDDER accepts all of the terms and conditions of the INSTRUCTIONS to BIDDERS, including without limitation those dealing with the disposal of the BID SECURITY. This BID will remain open for sixty days after the day of BID opening. BIDDER will sign the AGREEMENT and submit the documents required by the CONTRACT DOCUMENTS within ten (10) days after the date of the CITY'S NOTICE of AWARD.
3. In submitting this BID, the BIDDER represents, as more fully set forth in the AGREEMENT, that:
  - (a) The BIDDER has examined copies of the NOTICE TO BIDDERS, the INSTRUCTIONS TO BIDDERS, the PLANS and SPECIFICATIONS, the Supplementary Conditions and all other CONTRACT DOCUMENTS, and also the following addenda:

Date	Number	Topic
<hr/>		
<hr/>		

the receipt of all of which is hereby acknowledged.

- (b) BIDDER has examined the site and locality where the work is to be performed, the legal requirements (FEDERAL, STATE, and LOCAL, laws, ordinances, rules and regulations) and, conditions affecting cost, progress or performance of the WORK, and has made such independent investigations as BIDDER deems necessary.
- (c) This BID is genuine and not made in the interest of or on behalf of any undisclosed person, firm or corporation, and is not submitted in conformity with any agreement or rules of any group, association, organization, or corporation; BIDDER has not directly or indirectly



**BID FORM - PROJECT: 2021 SANITARY AND STORM SEWER REPAIRS**

ITEM NO.	DESCRIPTION	ESTIMATED QUANTITY	UNIT	LABOR PRICE	MATERIAL PRICE	TOTAL UNIT PRICE	TOTAL ESTIMATED COST
1	Pavement Removal and Disposal including full depth Saw Cut, reinforced or non-reinforced, per Specification	180	Sq. Yd.	\$	\$	\$	\$
2	Replacement of Sewer with 8" to 12" PVC Pipe including Trench Excavation up to 10 ft. Deep and Trench restored with Special Backfill	130	Lin. Ft.	\$	\$	\$	\$
3	Replacement of Sewer with 8" to 12" PVC Pipe including Trench Excavation over 10 ft. Deep and up to 16 ft. Deep and Trench restored with Special Backfill	30	Lin. Ft.	\$	\$	\$	\$
4	Replacement of Sewer with 8" to 12" PVC Pipe including Trench Excavation up to 10 ft. Deep and removed material used as Backfill and restored with 3 inches of Top Soil, including seeding and mulching	20	Lin. Ft.	\$	\$	\$	\$
5	Replacement of Sewer with 8" to 12" PVC Pipe including Trench Excavation over 10 ft. Deep and up to 16 ft. Deep and removed material used as Backfill and restored with 3 inches of Top Soil, including seeding and mulching	8	Lin. Ft.	\$	\$	\$	\$
6	Replacement of Sewer with 13" to 18" PVC Pipe including Trench Excavation up to 10 ft. Deep and Trench restored with Special Backfill	8	Lin. Ft.	\$	\$	\$	\$
7	Replacement of Sewer with 13" to 18" PVC Pipe including Trench Excavation over 10 ft. Deep and up to 16 ft. Deep and Trench restored with Special Backfill	6	Lin. Ft.	\$	\$	\$	\$
8	Replacement of Sewer with 13" to 18" PVC Pipe including Trench Excavation up to 10 ft. Deep and removed material used as Backfill and restored with 3 inches of Top Soil, including seeding and mulching	6	Lin. Ft.	\$	\$	\$	\$
9	Replacement of Sewer with 13" to 18" PVC Pipe including Trench Excavation over 10 ft. Deep and up to 16 ft. Deep and removed material used as Backfill and restored with 3 inches of Top Soil, including seeding and mulching	4	Lin. Ft.	\$	\$	\$	\$
10	Replacement of Sewer with 8" to 12" PVC Pipe including Trench Excavation over 16 Feet upto 19 Feet Deep and Trench restored with Special Backfill	4	Lin. Ft.	\$	\$	\$	\$

**BID FORM - PROJECT: 2021 SANITARY AND STORM SEWER REPAIRS**

ITEM NO.	DESCRIPTION	ESTIMATED QUANTITY	UNIT	LABOR PRICE	MATERIAL PRICE	TOTAL UNIT PRICE	TOTAL ESTIMATED COST
11	Replacement of Sewer with 13" to 18" PVC Pipe including Trench Excavation over 16 Feet Deep upto 19 Feet and Trench restored with Special Backfill	4	Lin. Ft.	\$	\$	\$	\$
12	Replacement of Sewer Lateral with 6" PVC Pipe including Trench Excavation up to 8 ft. Deep and Trench restored with Special Backfill	70	Lin. Ft.	\$	\$	\$	\$
13	Replacement of Sewer Lateral with 6" PVC Pipe including Trench Excavation over 8 ft. Deep and up to 12 ft. Deep and Trench restored with Special Backfill	40	Lin. Ft.	\$	\$	\$	\$
14	Replacement of Sewer Lateral with 6" PVC Pipe including Trench Excavation up to 8 ft. Deep and removed material used as Backfill and restored with 3 inches of Top Soil, including seeding and mulching	10	Lin. Ft.	\$	\$	\$	\$
15	Replacement of Sewer Lateral with 6" PVC Pipe including Trench Excavation over 8 ft. Deep and up to 12 ft. Deep and removed material used as Backfill and restored with 3 inches of Top Soil, including seeding and mulching	6	Lin. Ft.	\$	\$	\$	\$
16	4 inch thick Concrete Sidewalk Replacement, at locations as directed by the Engineer	60	Sq. Ft.	\$	\$	\$	\$
17	Concrete Pavement Replacement with minimum 9 inch thick Portland Cement Non-Reinforced Concrete, including excavation and disposal of the temporary asphalt patch material, at locations as directed by the Engineer	40	Sq. Yd.	\$	\$	\$	\$
18	Pavement Replacement with 3 inch Asphalt Surface over 8 inch thick Portland Cement Non-Reinforced Concrete, minimum, including excavation and disposal of the temporary patch material, at locations as directed by the Engineer	130	Sq. Yd.	\$	\$	\$	\$
19	Overtime Premium Pay per Man-hour worked on a Saturday, Sunday, Legal Holiday, or between 6:00 PM and 6:00 AM on a weekday, when and if Directed by the Engineer	10	Hours	\$	\$	\$	\$
20	Manhole Casting Adjusted to Grade in Concrete Pavement Area, including Replacement Pavement, 6" Maximum	1	Each	\$	\$	\$	\$
21	Manhole Casting Adjusted to Grade in Asphalt Pavement Area, including Replacement Pavement, 6" Maximum	1	Each	\$	\$	\$	\$

**BID FORM - PROJECT: 2021 SANITARY AND STORM SEWER REPAIRS**

ITEM NO.	DESCRIPTION	ESTIMATED QUANTITY	UNIT	LABOR PRICE	MATERIAL PRICE	TOTAL UNIT PRICE	TOTAL ESTIMATED COST
22	Reconstruction of a Street Storm Sewer Inlet per City Std. Drawing #1-501, including Excavation, up to 4 ft. of pipe connected and in place, Special Backfill and Pavement Removal and Replacement pavement as needed (any new CI Frame and/or Grating required will be furnished to the Contractor by the City at no Cost to the Contractor)	4	Each	\$	\$	\$	\$
23	Reset Existing or Replacement Street Inlet Casting to Grade including Excavation, Special Backfill and Pavement Removal and Replacement Pavement as needed (any new CI Frame and/or Grating required will be furnished to the Contractor by the City at no Cost to the Contractor)	1	Each	\$	\$	\$	\$
24	3 Man Crew and Equipment for Emergency Sewer Repair Work, as specified by the Engineer	16	Hours	\$	\$	\$	\$
25	2 Man Crew and Equipment for Emergency Sewer Repair Work, as specified by the Engineer	4	Hours	\$	\$	\$	\$
26	Fixed Allowance for Material Furnished and Installed by the Contractor with work NOT under Bid Items 2,3,4,5,6,7,8, 9, 10 & 11	1	L.S.	\$---	\$----	\$-----	\$ 3,000.00
27	48 inch Standard Sanitary Manhole per City Std. Dwg #1-601 up to 10' deep, as a replacement or new manhole, including Excavation, up to 12 ft. of pipe connected and in place, and Special Backfill but Excluding Concrete Pavement Removal and Replacement (Any New Manhole CI Frame and/or Cover required, will be furnished to the Contractor by the City at no Cost to the Contractor) with depth measured per Std. Dwg. #1-604R, Dated 2/4/2014	10	Lin. Ft.	\$	\$	\$	\$
28	6 inch thick Concrete Sidewalk or Driveway Apron Replacement, at locations directed by the Engineer	100	Sq. Ft.	\$	\$	\$	\$
29	Contingency, per Engineer	1	L.S.	\$----	\$----	\$----	\$ 3,000.00
	<b>TOTAL</b>						\$

UNOFFICIAL TOTAL : BID ITEMS (1) THROUGH (29) \$ \_\_\_\_\_

7. The following documents are attached to and made a condition of this BID:

- (a) BID SECURITY, in the form of \_\_\_\_\_.
- (b) City EEO Form
- (c) City Affirmative Action Form
- (d) Resolution of Directors, if bid is by a Corporation.
- (e) Bidder's Insurance Agent's Affidavit, signed by the agent
- (f) Bidder's Affidavit, signed by the bidder

The bidder is a \_\_\_\_\_. (Insert Individual, Partnership, Corporation, or Joint Venture.)

This PROPOSAL is signed on this \_\_\_\_\_ day of \_\_\_\_\_, 2021.

BIDDER: \_\_\_\_\_ (SEAL)  
(Firm Name)

By: \_\_\_\_\_ Title: \_\_\_\_\_  
(Printed Name)

By: \_\_\_\_\_ Attest: \_\_\_\_\_  
(Authorized Signature)

BUSINESS ADDRESS: (Address to which all official notices are to be sent.)

\_\_\_\_\_  
\_\_\_\_\_

Telephone Number: (\_\_\_\_) \_\_\_\_\_ - \_\_\_\_\_ FAX Number: (\_\_\_\_) \_\_\_\_\_ - \_\_\_\_\_

Email Address \_\_\_\_\_

(NOTE: If BID is by a partnership, a partner must sign; if the BID is by a corporation, an authorized officer must sign, and seal is to be affixed; and if BID is by a joint venture, all members of the joint venture must sign).

2021 SANITARY AND STORM SEWER REPAIRS

**BID GUARANTY AND CONTRACT BOND**

(OHIO REVISED CODE SECTION 153.571)

Bond Number \_\_\_\_\_

KNOW ALL MEN BY THESE PRESENTS, that we, the undersigned \_\_\_\_\_

(Bidder's Name and Address)

as principal and \_\_\_\_\_ (Name of Sureties) as sureties, are hereby held and firmly bound unto the City of Elyria, Ohio, as obligee in the penal sum of the dollar amount of the bid submitted by the principal to the obligee on \_\_\_\_\_ (Date) to undertake the project known as **2021 SANITARY AND STORM SEWER REPAIRS**. The penal sum referred to herein shall be the dollar amount of the principal's bid to the obligee, incorporating any additive or deductive alternate proposals made by the principal on the date referred to above to the obligee which are accepted by the obligee. In no case shall the penal sum exceed the amount of \$ \_\_\_\_\_ (Dollars in Figures) \_\_\_\_\_

(Dollars in Words). (If the amount in figures and the amount in words are different, the amount in words shall be used as the amount intended.) (If the foregoing blank is not filled in, the penal sum will be the full amount of the principal's bid, including alternates. Alternatively, if the blank is filled in, the amount stated must not be less than the full amount of the bid including alternates, in dollars and cents. A percentage is not acceptable.) For the payment of the penal sum well and truly to be made, we hereby jointly and severally bind ourselves, our heirs, executors, administrators, successors, and assigns.

THE CONDITION OF THE ABOVE OBLIGATION IS SUCH, that whereas the above named principal has submitted a bid for **2021 SANITARY AND STORM SEWER REPAIRS**, Now, therefore, if the obligee accepts the bid of the principal and the principal fails to enter into a proper contract in accordance with the bid, plans, details, specifications, and bills of material; and in the event the principal pays to the obligee the difference not to exceed ten percent (10% ) of the penalty hereof between the amount specified in the bid and such larger amount for which the obligee may in good faith contract with the next lowest bidder to perform the work covered by the bid; or in the event the obligee does not award the contract to the next lowest bidder and resubmits the project for bidding, the principal pays to the obligee the difference not to exceed ten percent (10%) of the penalty hereof between the amount specified in the bid, or the costs, in connection, and printing and mailing notices to prospective bidders, whichever is less, then this obligation shall be null and void, otherwise to remain in full force and effect; if the obligee accepts the bid of the principal and the principal within ten (10) days after the awarding of the contract enters into a proper contract in accordance with the bid, plans, details, specifications, and bill of materials, which said contract is made a part of this bond the same as though set forth herein;

Now also, if the said principal shall well and faithfully do and perform the things agreed by obligee to be done and performed according to the terms of said contract; and shall pay all lawful claims of subcontractors, materialmen, and laborers for labor performed and materials furnished in the carrying forward, performing, or completing of said contract; we agreeing and assenting that this undertaking shall be for the benefit of any materialman or laborer having a just claim, as well as for the obligee herein; then this obligation shall be void; otherwise the same shall remain in full force and effect; it being expressly understood and agreed that the liability of the surety for any and all claims hereunder shall in no event exceed the penal amount of this obligation as herein stated.

The said surety hereby stipulates and agrees that no modifications, omissions or additions in or to the terms of the said contract or in or to the plans or specifications therefor shall in any wise affect the obligations of said surety on this bond.

Name of Bidder: \_\_\_\_\_ (SEAL)

By: \_\_\_\_\_ Title: \_\_\_\_\_  
(Printed Name)

By: \_\_\_\_\_ Attest: \_\_\_\_\_  
(Signature) (Signature)

Name of Surety: \_\_\_\_\_ (SEAL)

Surety Mailing Address: \_\_\_\_\_

By: \_\_\_\_\_ Title: \_\_\_\_\_  
(Printed Name)

By: \_\_\_\_\_ (Attorney-in-Fact)  
(Signature)

Surety Agent Mailing Address: \_\_\_\_\_

**CONSENT OF SURETY**

KNOW ALL MEN BY THESE PRESENTS, that we \_\_\_\_\_

(Name of Bidder) as principal and \_\_\_\_\_ (Name of Surety Company)

a corporation created and existing under the laws of the State of \_\_\_\_\_ and having

its principal office at \_\_\_\_\_

(Complete mailing address of Surety Company) are held firmly bound unto the CITY OF ELYRIA, OHIO, hereby jointly and severally and binding our heirs, successors, administrators, executors, legal representatives and assigns by these presents.

THE CONDITION OF THIS OBLIGATION are such that whereas, the above named principal submits

the herewith proposal for the construction of 2021 SANITARY AND STORM SEWER REPAIRS PROJECT to the CITY OF ELYRIA, OHIO, in conformance with the INVITATION TO BID, and with the INSTRUCTIONS TO BIDDERS. We, the above named surety, will meet all stipulations and will execute the Surety Bonds as hereinafter, to the above named principal in event he should be awarded a contract and in an amount of \_\_\_\_\_ (Amount in Words)

which is an amount equaling or exceeding the amount of said principal's bid plus all additive alternates, and guaranteeing its performance in conformity with the plans and specifications, and a payment bond in the amount of \_\_\_\_\_

\_\_\_\_\_ (Amount in Words) amount equaling or exceeding the amount of said principal's bid plus all additive alternates, as guaranteeing the payment of all laborers and suppliers of materials for the project, to the City of Elyria, Ohio.

**WITNESS OUR SIGNATURES** this \_\_\_\_\_ day of \_\_\_\_\_, 2021.

Name of Bidder: \_\_\_\_\_ (SEAL)

By: \_\_\_\_\_ Title: \_\_\_\_\_  
(Printed Name)

By: \_\_\_\_\_ Attest: \_\_\_\_\_  
(Signature) (Signature)

Name of Surety: \_\_\_\_\_ (SEAL)

By: \_\_\_\_\_ Title: \_\_\_\_\_  
(Printed Name)

By: \_\_\_\_\_ Attest: \_\_\_\_\_  
(Signature) (Signature)

Surety Agent Mailing Address: \_\_\_\_\_

\_\_\_\_\_

**BIDDER'S INSURANCE AGENT'S AFFIDAVIT**

Project: 2021 SANITARY AND STORM SEWER REPAIRS

I, \_\_\_\_\_, \_\_\_\_\_, first  
(Name) (Title)

being duly sworn do state the following:

(a) that I am an Insurance Agent.

(b) that I have reviewed the insurance requirements in the Supplementary Conditions, and have noted therein the requirements on insurance including the cancellation, and non-renewal provisions.

(c) that I am familiar with the insurance that \_\_\_\_\_  
(Bidders Name)

has in force, and that its insurance meets the City requirements, or that it can be amended to meet the City requirements.

(d) that if an award of contract is made by the City to the Bidder an insurance certificate will be issued within ten (10) days, which will include the **City of Elyria, Ohio, as a Named Insured.**

Further, Affiant sayeth naught.

\_\_\_\_\_  
(Agents Signature)

Sworn to and subscribed in my presence this \_\_\_\_\_ day of \_\_\_\_\_, 20\_\_.

\_\_\_\_\_  
(Notary Public)

(SEAL)

2021 SANITARY AND STORM SEWER REPAIRS

**(Attach Bidders Insurance Certificate to this page)**

(The insurance certificate may be submitted after the bid opening date.)

**TAX AFFIDAVIT**

STATE OF OHIO  
SS  
LORAIN COUNTY

I \_\_\_\_\_(Name), \_\_\_\_\_(Title),

of the \_\_\_\_\_(Company Name),  
first being duly sworn do depose and state that it has submitted a competitive bid for a contract, to be  
administered and awarded by the City of Elyria, Ohio.

Further, Affiant says that it was not charged with any delinquent personal property taxes, penalties or  
interest due or owing to the County of Lorain, State of Ohio, except as hereinafter stated:

\_\_\_\_\_

\_\_\_\_\_  
(If none, state "NONE". If due, state "AMOUNT DUE", together with assessed interest and penalty.)

Further, Affiant says that a copy of this statement, affirmed under oath shall be made a part of its bid  
and the contract to be awarded.

Further, Affiant sayeth naught.

Business Name: \_\_\_\_\_

By: \_\_\_\_\_ Title: \_\_\_\_\_

Sworn to and subscribed in my presence this \_\_\_\_\_ day of \_\_\_\_\_, 20\_\_.

(SEAL)

\_\_\_\_\_  
(NOTARY PUBLIC)

My Commission Expires \_\_\_\_\_, \_\_\_\_\_.

**BIDDER'S AFFIDAVIT**

This affidavit is to be filled out and executed by the BIDDER; if the bid is made by a corporation, then by it's properly authorized agent.

STATE OF OHIO \_\_\_\_\_)

SS)

COUNTY OF \_\_\_\_\_)

I, \_\_\_\_\_ being first duly sworn, deposes and says that he/she is \_\_\_\_\_ (sole owner, a partner, officer of, etc.) of the \_\_\_\_\_ (Name of Business) the party making the enclosed

bid; and says further that:

(Give the names of all persons, firms or corporations interested in the enclosed bid)

\_\_\_\_\_  
\_\_\_\_\_  
\_\_\_\_\_

\_\_\_\_\_ and that those listed are the only party or parties interested with the profits of any contract which may result from the herein contained bid; that the said proposal is made without any connection or interest in the profits thereof with any other person making any other bid or proposal for said work; that no member of the City Council, the head of any department , division, or bureau or employee therein or any officer of the City of Elyria, Ohio is directly or indirectly interested therein; that said bid is genuine and not collusion, or communication or conference, with any person, to fix the bid price of Affiant or any other bidder, or to fix any overhead, profit or cost element of said bid price, or that of any other bidder, or to secure any advantage against the City of Elyria, Ohio, or any person interested in the proposed contract; and that all statements contained in said proposal or bid are true; that such bidder has not, directly or indirectly submitted this bid, or contents thereof, or divulged information or data relative thereto to any association, or to any member or agent thereof; and further says that all the statements made by him in said proposal or bid are true.

\_\_\_\_\_  
AFFIANT

Sworn to and subscribed before me this \_\_\_\_\_ day of \_\_\_\_\_, \_\_\_\_\_.

\_\_\_\_\_  
Notary Public in and for,  
\_\_\_\_\_ County, Ohio

My commission Expires \_\_\_\_\_ year \_\_\_\_.

**PENALTY FOR FALSE CERTIFICATION**

Section 35 of the Criminal Code, as amended, provides a penalty of not more than \$10,000.00 or imprisonment of not more than ten years, or both, for knowingly and willfully making or causing to be made, "any false or fraudulent statements --- or use or cause to be made or used and false ---account, claim, certification, affidavit, or deposition, knowing the same to contain any fraudulent or fictitious statement --"relating to any matter within the jurisdiction of any Governmental Department or Agency.

## **BIDDER'S QUALIFICATIONS INFORMATION SHEET**

(This item is to be submitted with the bidder's bid.)

## SUPPLEMENTARY CONDITIONS

### I. INSURANCE LIMITS:

**LIABILITY, PROPERTY DAMAGE, VEHICLE AND BUILDER'S RISK INSURANCE:** Contractor shall purchase and maintain such comprehensive general liability and other types of insurance as will provide protection from claims as set forth herein which may arise out of or result from Contractor's performance of the work and Contractor's other obligations under all contract documents, whether such performance is by Contractor, by any lower subcontractor, by anyone directly or indirectly employed by any of them, or by anyone for whose acts any of them may be liable.

The claims types for which insurance shall be provided shall include:

- a) Claims under workers compensation, disability benefits and others similar employee benefit acts;
- b) Claims for damage because of bodily injury, occupational sickness, sickness, disease, or death of any person;
- c) Claims for damages, other than to the work itself, because of injury to or destruction of tangible property, including loss of the use resulting therefrom;
- e) Claims for damages because of bodily injury or death of any person or for property damage arising out of the ownership, leasing, renting, hires, loaned, or otherwise using, and the maintenance of any item of construction or equipment of any power tools by Contractor or a subcontractor;
- f) Claims for damages because of bodily injury or death of any person or for property damage arising out of the ownership, leasing renting or using maintenance of any motor vehicle, by Contractor or a subcontractor;
- g) Claims for damages to the work itself, and/or all existing City property located in the proximate area of the work, because of injury or destruction of the tangible property, including the loss of use resulting therefrom; and
- h) Claims for damages because of bodily injury or death of any person or property damage arising out of the use, transportation or storage of any type of explosives, explosive devices or dangerous ordnance use in doing work included in the Contract.

The insurance limits required by this section shall include the specific coverage as are applicable to the work, and shall be written for the specified limits stated herein, or for the specific limits as provided in any applicable supplementary specification, or as may be required by law, wherever is greater.

The Contractor shall have and maintain the type of insurance that provides the limits of coverage for each occurrence. If the Contractor's policy is not of the form providing coverage limits for each occurrence, then he shall obtain a rider providing coverage by occurrence for the work under this specification.

The insurance shall be written by a solvent and otherwise acceptable company(s) authorized to do business in the State of Ohio,

Evidence of insurance shall be provided by the Contractor to the City for review and acceptance by the City, before the issuance of the Notice to Commence.

Such evidence shall consist of the Contractors insurance agents "insurance affidavit" (when requested, on a form that is on file at the City Engineer's office) the Certificate of Insurance plus the Certificate of Compliance provided by the Ohio Department of Insurance for the Company(s) in question.

Failure to provide evidence of the maintenance of all of the required insurance shall suspend the City's obligation to pay for any and all work performed after the cessation of the required coverage for which evidence has previously been provided, and can be the basis of a non-compensable order to suspend work or for the termination of the contract for cause.

The Contractor's policy shall provide and the Certificate of Insurance shall reflect the fact that the City is an additional insured and all (if any) other additional insured shall receive at least thirty (30) days notice of any cancellation, change reducing the coverage, or refusal to renew, which is adverse to the interests of the City and/or other additional insured to

2021 SANITARY AND STORM SEWER REPAIRS

be effected. The City and other additional insured shall be provided with any notice on non-renewal, regardless of the cause.

The liability limits for the required coverage notes above shall be at least:

	<b>EACH OCCURRENCE</b>	<b>AGGREGATE</b>
Bodily Injury & Property Damage Combined	\$ 2,000,000.00	\$ 2,000,000.00
Vehicle Liability	\$ 1,000,000.00	\$ 1,000,000.00
Builders Risk/Installation Floater	(Not applicable to this project)	

**ANY AND ALL LIABILITY LIMITS SHALL BE EXCLUSIVE OF DEFENSE COSTS.**

**II. CONTROLLING LAW AND JURISDICTION:**

This Agreement shall in all respects be interpreted and construed in accordance with and governed by the laws of the State of Ohio. This Agreement shall be subject to the jurisdiction of the Court of Common Pleas Lorain County, Ohio.

**III. ENGINEER:**

Unless otherwise provided, the **Engineer** shall be the City of Elyria Engineer.

**IV. AGREEMENT FORM:**

Agreement form included in bid document is an example for bidder's reference and may be modified on an individual project basis.

## EQUAL EMPLOYMENT OPPORTUNITY CLAUSE

### During the performance of this contract, the contractor agrees as follows:

- 1) The contractor shall not discriminate against any employee or applicant for employment because of race, religion, age, color, sex, national origin or handicap. The contractor shall take affirmative action to insure that applicants are employed and that employees are treated without regard to race, religion, color, sex, national origin or handicap during employment.

As used herein, the work "treated" shall mean and include without limitation, the following:

**recruited:** whether in the form of rates of pay or other forms of compensation

**selected for training:** including apprenticeship, promoted, upgraded, transferred, laid off and terminated

The contractor agrees to and shall post in conspicuous places available to employees and applicants for employment, notices to be provided by the contracting officers setting forth the provisions of the non-discrimination clause.

- 2) The contractor shall, in all solicitations or advertisement for employees placed by or on the behalf of the contractor, state that all qualified applicants will receive consideration for employment without regard to race, religion, color, sex, national origin or handicap.
- 3) The contractor shall submit to the City, in writing, an affirmative action plan and shall furnish all information and reports required by the City or its representatives pursuant to this chapter and permit access to the contractor's books, records, and accounts by the contracting agency and affirmative action officials for purposes of investigation to ascertain compliance with the Affirmative Action Program. The contractor may comply with the provisions of this section by doing one of the following:
  - a) The contractor may submit its Affirmative Action Program in writing at the time of its submission of bid; or
  - b) The contractor may submit its Affirmative Action Program in writing prior to its submission of bid for precertification.

The contractor's Affirmative Action Program may be precertified upon the filing and approval of its Affirmative Action Program with the City's EEO office not more than six months prior to its bid submission. Upon precertification, the contractor will be issued a precertification compliance number for its Affirmative Action Program, which may be used and referred to in any bid submission in the place of any other written requirement for Affirmative Action Program submission. It shall be the sole responsibility of the contractor to be recertified upon the expiration of its precertification. Approved programs may be reviewed before any precertification expiration date.

- 4) The contractor shall send to each labor union or representatives of workers with which he/she has a collective bargaining agreement or other contract or understanding, a notice advising the labor union or workers' representative of the contractor's commitments under the Equal Employment Opportunity Clause of the City of Elyria and shall post copies of the notice in conspicuous places available to employees and applicants for employment.

2021 SANITARY AND STORM SEWER REPAIRS

- 5) The contractor shall take such action with respect to any subcontractor as the City of Elyria may direct as a means of enforcing the provisions of the EEO Clause including penalties and sanctions for noncompliance. Provided, however; that in the event the contractor becomes involved in or is threatened with litigation as a result of such direction by the City, the City will enter into such litigation as is necessary to protect the interests of the City and to effectuate the City's Equal Opportunity Program and in the case of contracts receiving federal assistance, the contractor or the City may request the United States to enter into such litigation to protect the interests of the United States.
- 6) The contractor shall file and shall cause his/her subcontractors, if any, to file compliance reports with the City in the form and to the extent prescribed by the City or its representative. Compliance reports shall contain information as to the employment practices, policies, programs and statistics of the contract and subcontractor(s).
- 7) The contractor shall include the provisions of the Equal Employment Opportunity Clause in every subcontract or purchase order so that such provisions will be binding upon each subcontractor and/or vendor.
- 8) Refusal by the contractor or subcontractor to comply with any provision of this program as herein stated and described will subject the offending party to any or all of the following penalties:
  - a) Withholding of all future payments under the involved public contracts to the contractor in violation until it is determined that the contractor or subcontractor is in compliance with the provision of this contract.
  - b) Refusal of all future bids for any public contract with the City or any of its departments or divisions until such time as the contractor or subcontractor demonstrates that he/she has established and shall carry out the policies of the programs as herein outlined.
  - c) Cancellation of the public contract and declaration of forfeiture of the performance bond.
  - d) In cases in which there is substantial or material violation or the threat of substantial or material violation of the compliance procedure or as may be provided by contract, appropriate proceedings may be brought to enforce these provisions, including the enjoining within applicable laws of contractors, subcontractors or other organizations, individuals, or groups who prevent directly or indirectly or seek to prevent directly or indirectly compliance with the policy as herein outlined.

\_\_\_\_\_  
Name of Company Official

\_\_\_\_\_  
Title

\_\_\_\_\_  
Name of Company

\_\_\_\_\_  
Area Code/Telephone Number

\_\_\_\_\_  
Signature of Company Official

\_\_\_\_\_  
Date Signed

## CONTRACTOR'S/VENDOR'S AFFIRMATIVE ACTION INFORMATION SHEET

This Affirmative Action Information Sheet is to be completed and returned with the bid.

Bidder's EEO Officer's Name: \_\_\_\_\_

Bidder's EEO Officer's Title: \_\_\_\_\_

Bidder's Firm Name: \_\_\_\_\_

Address: \_\_\_\_\_

City/State/Zip Code \_\_\_\_\_

Phone: (\_\_\_\_\_) \_\_\_\_\_ - \_\_\_\_\_ Fax Number: (\_\_\_\_\_) \_\_\_\_\_ - \_\_\_\_\_

Note: The bidder must comply with either #1 or #2 below. (Please place a check mark in the correct item.)

#1 \_\_\_\_\_ Our firm has been precertified, by Elyria's EEO Officer.

Our precertification number is: \_\_\_\_\_

Our precertification expires on: \_\_\_\_\_

\_\_\_\_\_ A copy of our precertification letter from Elyria is attached.

#2 \_\_\_\_\_ We are enclosing our own Affirmative Action Plan (number of page(s) \_\_\_\_\_) with this bid.

\*\*\*\*\*

(for city office use only)

**CITY OF ELYRIA SIGN-OFF:**

Affirmative Action/Equal Opportunity Officer: \_\_\_\_\_

Comments:

---

---

---

---

CONTRACTOR/SUPPLIER AFFIRMATIVE ACTION PROGRAM  
 TOTAL PRESENT WORKFORCE BREAKDOWN  
 TABLE 1

JOB CATEGORY	TOTAL MALES	MALE EMPLOYEES MINORITY GROUPS				TOTAL FEMALES	FEMALE EMPLOYEES MINORITY GROUPS				TOTAL ALL EMPLOYEES	
		[WHITE]	BLACK	SPANISH	OTHER MINORITY		WHITE	BLACK	SPANISH	OTHER MINORITY		
OFFICIALS/ ADMINISTRATORS												
PROFESSIONALS												
TECHNICIANS												
PROTECTIVE SERVICE												
SALES												
PARAPROFESSIONALS												
OFFICE-CLERICAL												
SKILLED CRAFT SPECIFY												
JOURNEYMEN												
HELPERS												
APPRENTICES												
TRAINEES												
LABORERS												
SERVICE/CUSTODIAL												
OTHERS (SPECIFY)												
<b>TOTALS</b>												

**CITY OF ELYRIA  
DEPARTMENT OF PUBLIC SERVICE  
ENGINEERING DIVISION**

**SPECIFICATIONS**

**May 2021**

**SANITARY SEWER SYSTEM REPAIRS AND  
STORM SEWER SYSTEM REPAIRS**

- 1. SCOPE OF WORK:** The Contractor shall provide all labor, materials, equipment, supplies and supervision necessary to repair and/or make minor improvements to the public sanitary, storm or combination sewers owned and operated by the City of Elyria and building laterals located in the public right-of-way at those locations identified and authorized by the City.
- 2. NON-EXCLUSIVE CONTRACT:** The City shall have the right to determine what work, if any work, shall proceed under this contract. The City may use City forces, or other contractors as deemed necessary, to make repairs to the sewer system.
- 3. SPECIFICATIONS:** All work shall be performed in accordance with City of Elyria Standard Drawings, ODOT Standard Drawings and the Ohio Department of Transportation Construction and Materials Specifications dated January 1, 2019 as published by ODOT, a copy is on file at the office of the City Engineer on the date that this Contract was first advertised for bids.
- 4. LENGTH OF SERVICE CONTRACT:** The contractor will have until December 31, 2022 to complete the Work or until contract funds are depleted.
- 5. SITE OF WORK:** No sites of work are specified for this contract. The location of work may be in a public road, street, alley, or right-of-way. It also may be within an easement to the City for a public sewer which is located on private property. The City makes no guarantee that a road or hard surface will be available to reach all sites of work.

Locations that are **excluded** from the work quoted under the bid unit prices stated (except the hourly rates bid) in the proposal are as follows:

- a. Crossings in the Ohio Turnpike right-of-way.
- b. City sewers on railroad right-of-way.
- c. Work on sewer system siphons.
- d. Work on stream crossing, including both branches of the Black River.
- e. Sewers attached to bridge structures.
- f. Sewers located under structural surface slabs on earth fill arch bridges.
- g. Pipe located inside the bar screens at any lift station or located at the Wastewater Pollution Control Plant.
- h. Pipe located within 5'-0" of (horizontal measurement to outside wall) or under buildings.

**6. AUTHORIZATION OF WORK AGAINST CONTRACT:** The Contractor will be authorized by the City Engineer to proceed with work on this contract. No other procedures or forms of authorization will be accepted for billing by the City under the contract. The authorization shall include the location of the site, objective of the dig, and the type of pipe (sanitary, storm or combination sewer) to be exposed by excavation by the Contractor for repair.

**7. RESPONSE TIME: In a non-emergency event the Contractor shall report to a site within three (3) working days (Monday through Friday excluding Saturday, Sunday and legal holidays) after the City provides notification authorizing the performance of work at a specific location.**

If the sewer system is blocked or other emergency exists (in the opinion of the City Engineer), the City shall require the Contractor to report to the site within twenty-four (24) hours from the time of notification. If the Contractor is unable to respond within the stated timeframe, the City may use other means to make the necessary repairs. The overtime premium pay item shall be due the Contractor in instances where the City directs the Contractor to begin work and continue the work until the repair is completed and placed back into service, and results in the working hours that are prior to 6:00 a.m. and past 6:00 p.m. during a normal Monday through Friday (overtime between the hours of 12:01 a.m. to 6:00 a.m. and 6:00 p.m. to midnight), or during Saturday, Sunday or legal holidays. The response time for storm sewer work requiring PVC pipe or fittings greater than 18" diameter or 36" diameter and greater concrete pipe shall be extended by no more than five (5) days to allow ordering and delivery time for those items. The Contractor will be expected to have ready access to supplies as needed for 18" diameter and smaller PVC pipe and fittings and 30" diameter and smaller reinforced concrete pipe without an extension of response time.

Contractor is expected to perform authorized work during normal business hours, 8:00 a.m. to 4:30 p.m., whenever possible. Contractor shall provide the service requested in this contract in the timeframe requested by the Engineering Department for the safety and welfare of the residents of Elyria.

**8. UTILITIES:** The Contractor shall be responsible for notifying the utilities that may be affected by the work including, but not limited to, the following: Ohio Edison, Windstream, Columbia Gas of Ohio, Time Warner, Charter Communications, Everstream, Crown Castle, Elyria City Water Distribution Department, Elyria City Wastewater Department, Avon Lake Municipal Utilities, Lorain County Rural Water Authority, and Ohio Utilities Protection Service.

**9. MAINTAINING TRAFFIC:** The Contractor shall furnish, install and maintain all construction area traffic control warning and barricade items per Ohio Manual of Uniform Traffic Control Devices (OMUTCD). When pavement has been removed, the Contractor shall maintain the traffic control deemed necessary per the OMUTCD until the replacement pavement can be opened to traffic. Where the work area is accessible to pedestrians, the Contractor shall mark and barricade any excavation left unattended. The Contractor shall be responsible to protect the work area with proper devices and methods. If the Contractor requests to use fast setting concrete to decrease the duration required for maintenance of traffic, all costs associated with the Contractor's work methods would be at no additional expense to the City.

**10. MAINTAINING FLOW:** The Contractor shall appropriately schedule work and shall maintain adequate sewage flow in the gravity systems during the performance of the work.. There will be occasions when the Contractor will be required to provide minor temporary diversion and pumping of sewage to complete the necessary work. In the event that work is to be performed on a gravity sewer of 18” diameter or greater with significant gravity flow, the Contractor will perform the work at a negotiated reasonable unit price with the City to effectively maintain sewage flow. At no time shall existing storm sewers or drain tile be plugged without the approval of the City. In the event that work is to be performed on a forcemain, the Contractor will perform the work at a negotiated reasonable unit price with the City to effectively maintain sewage flow.

The City may, at the City's option, use City-owned sewer equipment to unplug existing sewers at the repair site.

**11. PAVEMENT REMOVAL:** When the repair location requires the removal of pavement, the pavement shall be saw cut **FULL** depth to form a neat vertical edge and hydraulic hammer (or other means by industry standard) used to break up the pavement. Payment for the removal and replacement of rigid, composite, or flexible pavement with a depth over 5”, shall be made at the unit price bid which shall apply to the full area of the patch, including the area removed to obtain a neat vertical edge. Payment for saw cutting shall be considered as incidental to the cost of the pavement removal and is to be included with the unit price bid for pavement removal. **ANY PAVEMENT DAMAGED OUTSIDE OF THE DESIGNATED DIG AREA (MARKED BY THE ENGINEERING DEPARTMENT) SHALL BE REPAIRED AT THE CONTRACTOR’S EXPENSE.**

The Contractor shall be responsible for the appropriate disposal of the removed materials. The City **DOES NOT**, as part of this Contract, furnish a disposal site.

The removal of composite pavement consisting of an asphalt wearing surface on slab stone, concrete or brick, is to be paid for under the respective pavement removal pay item. Full depth asphalt pavement on stone base with 5” or less of asphalt shall not be paid as a pavement removal item but payment will be made as an excavation pay item.

**12. TRENCHING:** The trenching bid items shall include removal and excavation of all materials, except concrete pavement, as unclassified material. The trenching work shall include all shoring and bracing, backfilling and protection of the excavation and of the work area. Trench backfill shall be either suitable excavated material, when approved by the Engineer, or ODOT No. 304 limestone, as furnished by the Contractor. Work under this item shall be performed in accordance with City specifications, and shall include the disposal of all excess removed materials, and furnishing of special backfill when required.

**13. TRENCHING LIMITS:** In the event that multiple pipes, including water services, are included in the work, the method of payment will be based on the respective trenching pay item associated with the pipe located at the lower elevation. Quantities in addition to the described lower pipe will be paid using the actual material cost only plus fifteen percent (15%) for the corresponding pipe size(s) located within the trench limits.

**14. REPLACEMENT PAVEMENT:** Pavement shall be replaced with a material and finished surface that will closely match the adjoining surface with all pavement joints sealed. When a temporary surface is placed a minimum 3" asphalt on a 4" aggregate base shall be furnished and maintained by the Contractor until the permanent replacement pavement is constructed. When it is necessary to place steel traffic plates over the work area, the plate(s) are to be placed in a fashion that will follow the cross slope of the existing surface. The Contractor may be required to feather the edges of the plate to the existing pavement surface with an asphalt wedge to allow for a smooth transition along the driving surface. If the Engineer deems a plate is unsatisfactory and does not comply with the intent of the specification, the contractor shall remove the plate and replace it with an approved plate(s). The thickness of the plate shall be dependant on the dimensions of the trench and traffic conditions to ensure the safety of the public. No special payment will be made for temporary surfaces and/or traffic plates.

Pavement subbase shall consist of a minimum of 6" ODOT 304 and compacted per the specification.

The permanent concrete replacement pavement shall comply with the minimum pavement thicknesses indicated below or match existing pavement thickness, whichever is greater.

	Concrete (Class C)	Asphalt (ODOT 448 Type 1, Surface)
Asphalt pavement:	8" min.	3"
Concrete pavement:	9" min.	None

Within the pavement limits, the permanent pavement replacement shall be constructed a minimum of 12" past the edge of the long side of the trench excavation. Hook bolts shall be included in the replacement pavement. See drawing for details.

The permanent asphalt replacement pavement shall be compacted with mechanical rollers as per ODOT 401.16.

Concrete pavement materials and placement shall comply with the applicable ODOT specification. Concrete shall be ODOT Class "C" concrete. Fast setting concrete shall not be used unless approved by the Engineer. If the Engineer requests the use of fast setting concrete, additional payment would be made to the Contractor based on the increased actual cost of material only.

The joint(s) between existing and replacement pavement shall be sealed by the Contractor as part of the work. The replacement pavement and existing pavement joint(s) are to be sealed with hot applied bituminous joint sealer meeting the respective ODOT Specification.

**15. MAXIMUM LENGTH OF WORK AND MINIMUM PAY LENGTH:** The intent of this Contract is for the isolated spot repairs of sanitary and storm sewers. The maximum individual length of pipe repaired will be thirty (30) linear feet at the site of work and the minimum repair pay item length for the respective replacement pipe shall be six (6) linear feet at the site of work.

**16. MOBILIZATION:** The cost of mobilization shall be included in the bid price of the pay items listed in the proposal. No separate payment will be made for mobilization.

**17. MINIMUM PAY ITEMS:** After performing an authorized excavation, the pipe is exposed or not found and no sewer pipe repair was performed, the minimum pay item(s) shall include twenty-five percent (25%) of the applicable unit price payment for Bid Items Nos. 2-15 plus the following as applicable: pavement removal, pavement replacement, driveway apron or sidewalk replacement. No additional payment for pipe items shall be made.

**18. SPECIAL BACKFILL ON LATERAL PIPES:** Bid items on lateral pipes shall include the furnishing and placement of ODOT No. 304 limestone as special backfill for backfill under pavement and two feet past curb, driveway apron and sidewalk.

**19. SPECIAL BACKFILL:** Special Backfill shall be ODOT No. 304 limestone.

**20. CASTINGS:** Any new street inlet casting required for work under Bid Items 22 or 23 will be furnished by the City at no cost to the Contractor. New Manhole Castings required for any of the bid items will be furnished by the City to the Contractor at no cost to the Contractor.

**21. RESETTING STREET INLET:** Work under Bid Items 22 and 23 shall include saw cutting the concrete pavement in an area of approximately 10'-0" by 4'-0" wide or 40 square feet (see Standard Drawing 1-501) and removing the pavement around the inlet. The work will also include removing the curb behind the inlet, casting frame and adjusting the grade of the support by up to 3± inches (either up or down) and then resetting the inlet frame. Concrete pavement shall be replaced with curb as shown on Standard Drawing 1-501. Payment will be made at the unit price bid for each street inlet reset. Up to 4 feet of pipe shall be included in the resetting of the inlet. Any pipe quantities beyond 4 feet shall be paid actual material plus 15%. Pipe replaced outside of the 40 square foot excavation shall be paid per unit price bid. (No additional payment will be made for removal or pavement replacement under the other bid items in the proposal.)

**22. THREE MAN CREW & EQUIPMENT FOR EMERGENCY REPAIRS:** Work under Bid Item 24 will be carried out only when the needed repair work e.g. on a force main or when it cannot be classified under the other bid items in the proposal. Under Bid Item 24 the Contractor shall furnish a crew and equipment for emergency repairs. A full crew will consist of three (3) workers plus supervision. Typically the three (3) workers would be an equipment operator, a truck driver, and a laborer. The minimum equipment would include excavating equipment that can work to a depth of fifteen (15) feet below grade and a truck of approximately 12 cubic yards capacity for hauling surplus material and special backfill. Additional equipment under this item would include pumps and other miscellaneous equipment as needed and all work area traffic control items. The hours measured for payment will include all time at the work site plus 30 minutes maximum for travel to the site and 30 minutes maximum returning to the Contractor's yard. The hours of work at the unit bid price for Bid Item 24 will be between 6:00 a.m. and 6:00 p.m., Monday through Friday (non-holiday). If work under this item is done outside of those hours or during Saturday, Sunday or legal holiday at the request of the City, then the unit price bid for Bid Item 19, overtime premium pay per man-hour shall apply to each crew member and the Contractor's on-site supervisor. For safety purposes, the contractor shall have no less than two people onsite at all times.

**23. TWO MAN CREW & EQUIPMENT FOR EMERGENCY REPAIRS:** Work under Bid Item 25 will be carried out only when the needed repair work e.g.a force main or when it cannot be classified under the other bid items in the proposal. Under Bid Item 25 the Contractor shall furnish a crew and equipment for emergency repairs. A full crew will consist of two (2) workers plus supervision. Typically the two (2) workers would be an equipment operator and a laborer. The minimum equipment would include excavating equipment that can work to a depth of fifteen (15) feet below grade. Additional equipment under this item would include pumps and other miscellaneous equipment as needed and all work area traffic control items. The hours measured for payment will include all time at the work site plus 30 minutes maximum for travel to the site and 30 minutes maximum returning to the Contractor's yard. The hours of work at the unit bid price for Bid Item 25 will be between 6:00 a.m. and 6:00 p.m., Monday through Friday(non-holiday). If work under this item is done outside of those hours or during Saturday, Sunday or holiday at the request of the City, then the unit price bid for Bid Item 19 , overtime premium pay per man-hour shall apply to each crew member and the Contractor's on-site supervisor. For safety puposes, the contractor shall have no less than two people onsite at all times.

**24. FIXED ALLOWANCE FOR MATERIALS:** The proposal includes an item for special materials requested by the City used in making repairs. **The cost of the pipe, joints, common fittings, common adapters and other common appurtenances required for Bid Item Nos. 2 through 15 shall be covered in the unit price for respective items and no separate payment shall be made.** The material furnished will be special pipe fittings, adapters and/or concrete encasement. The installation of these materials would be paid for under bid items listed in the proposal. Material items paid for will be at the **ACTUAL** cost of the material from the supplier plus freight cost plus 15% of the material cost required to complete the work. For example, if a 3-foot long section of special pipe is needed, and it is cut from a 4-foot piece of pipe, the payment will be for the actual 3-foot section used. An invoice for the materials shall be produced as a proof of purchase. Any common materials included in the repair of the sewer as required by Bid Item Nos. 2 to 15 shall not be paid under this item. Material for sewer drops or additional lateral within a trench would also qualify as material cost + 15%.

**25. ESTIMATED QUANTITIES AND LIMIT UNDER CONTRACT:** The quantities listed in the proposal are only estimated quantities to be used during the evaluation of the bids. Bids will be evaluated based on the total cost under the UNOFFICIAL TOTAL. The City reserves the right to increase or decrease specific quantities on specific pay items that are necessary to complete the work.

However, the City agrees not to increase the total dollar amount of the work by more than 10% above the total amount bid on the base bid items without an agreement to the increase by the Contractor. Pay items for the various items shall be shown on the City Standard Drawing entitled "Sanitary Sewer Repairs, Method of Measurement." Further, the City reserves the right to decrease the amount of the award by decreasing selected specific quantities up to 50% if necessary to have the contract amount not exceed the dollars budgeted by the City for this work.

**26. METHOD OF MEASUREMENT AND PAYMENT:**

**BID ITEM 1:** Measurement and payment for this bid item shall be made as per "11. PAVEMENT REMOVAL" above.

**BID ITEMS 2 TO 15:** Existing sewer pipe or lateral shall be replaced with PVC pipe of equal size under these items. Quantity for payment shall be actual length of exposed pipe at bottom of trench, L1 or L2 as shown on attached drawing 1-604R (Revised on 12-16-2013), irrespective of length of PVC pipe replaced, not exceed the length of the trench. The Bid Price shall include cost of pipe, joints, fittings and appurtenances required for the repair. The Bid Price shall also include the first six (6) feet of lateral, including riser, fittings, joints, and all appurtenances, located in the excavated trench. Additional lateral pipe quantities, joints, or fittings within the excavation that exceed the six (6) feet in quantity shall be paid actual material cost plus 15%. Any lateral pipe or sewer pipe that requires replacement which causes additional excavation outside the main excavation shall be paid using the corresponding bid item, measuring from the edge of the main excavation trench.

Minimum length of trench to be paid at one time shall be six (6) feet. **Unless approved by the Engineer, the sewer pipe to be replaced shall extend the entire length of the trench.**

If a 6" sewer is determined to be a "main" as opposed to a lateral, the lineal footage of 6" sewer shall be paid using the corresponding 6" lateral price per foot, ITEMS 12-15.

**BID ITEM 19:** Payment under this bid item shall be made for actual man-hours at the item rate bid by the contractor regardless of classification. For example, if Contractor has bid a rate of "\$x" per man-hour, and deploys one (1) operator, one (1) laborer, and one (1) truck driver for three (3) hours to make a repair on a Saturday, Sunday, Legal Holiday, or between 6:00 PM and 6:00 AM on a weekday, payment shall be made for nine (9) man-hours (3 workers x 3 hours worked) at the rate of "\$x". Payment for the work performed shall be made at the unit price bid for the pertinent items.

**27. DRIVEWAY APRONS:** When the work requires removal and replacement of a driveway apron, the limits of removal and replacement shall be extended to existing joint lines or approved saw cut lines. Apron replacement shall be 6" thick concrete.

**28. CITY WATER:** The City may provide a water truck with water to the contractor to assist with trench compaction as approved by the City Engineer, or designated representative. The contractor shall not obtain water from a hydrant without approval from the Engineer and the City of Elyria Public Utilities Department.

**29. VACTOR TRUCK:** The City may assist with removal of sewage from a trench by providing a sewage vactor truck, as deemed necessary by the City Engineer, or designated representative.

**30. DETOURS FOR MAJOR ROUTES:** The contractor will be responsible for supplying, installing and removing signs and other traffic control devices required for the detouring of traffic. The contractor must notify the Engineer a minimum of 24 hours prior to detouring traffic, or as soon as reasonably possible.

- 31. SEEDING, MULCHING AND TOPSOIL:** The Contractor shall follow ODOT Item 659 Seeding and Mulching specification and ODOT Item 653 Topsoil Furnished and Placed. The cost of Seeding and Mulching and Topsoil is to be considered as incidental to the respective pay item(s) and the Contractor shall include this work in the bid price of the pay items listed in the proposal. No additional payment will be made for Seeding and Mulching or Topsoil.
- 32. ACTUAL MATERIAL COST:** Contractor shall supply the City with invoices for verification of ACTUAL COST of Materials. Contractor may add 15% to the Actual Material Cost for materials. Actual Material Cost shall only to paid by the City as specified and shall be included in Line Item 29 Contingency.
- 33. EXAMPLE DRAWINGS:** The “Pay Item Examples” are illustrations to show how the cost of an excavation is calculated. The drawings do not show the 12” cutback (benching) on the long sides of the trench for drawing purposes only. These drawings shall not be construed as instruction to the means and methods used by the contractor for this contract.
- 34. FITTINGS: Fittings shall include hard back couplings. Use of hard back fittings will increase the strength at the joint and decrease future failures due to shear forces.** (Standard drawing and examples have not been updated with this option)

NOTES: METHOD OF MEASUREMENT OF PAY QUANTITIES

(1) D IS MEASURED FROM THE PAVEMENT SURFACE OR ADJACENT GROUND LINE TO THE PIPE INVERT LINE. USE THE DEPTH AT THE MIDPOINT OF THE REPAIR SECTION FOR DETERMINING WHICH PAY ITEM NUMBER IS APPLICABLE.

(2) PAVEMENT REMOVAL AND REPLACEMENT: AREA = (W X L)/9 WHERE W SHALL BE ACTUAL WIDTH UNLESS ACTUAL WIDTH EXCEEDS MAXIMUM PAY WIDTH IN TABLE ON THIS SHEET. THE PAY LENGTH (L) FOR EACH SEPARATE EXCAVATION SHALL BE THE ACTUAL LENGTH SPECIFIED FOR REMOVAL BY THE CITY ("W" MAY BE INCREASED BY DIRECTION OF THE CITY TO REPLACE PAVEMENT TO EXISTING JOINT LINES).

(3) THE PAY LENGTH FOR ITEMS 2 TO 15 SHALL BE ACTUAL LENGTH OF PIPE EXPOSED AT THE BOTTOM OF TRENCH BUT NOT LESS THAN 6 FT.

SEWER REPAIR:

(4) CONTRACTOR SHALL USE FERROCS FOR CONNECTING NEW PIPE TO EXISTING. A CONCRETE COLLAR CONSTRUCTED WITH MORTAR FOR WATER TIGHT JOINTS SHALL BE USED ONLY WHEN APPROVED BY ENGINEER

(5) THE PAY DEPTH FOR NEW OR REPLACEMENT MANHOLE SHALL BE ACTUAL DEPTH OF MANHOLE FOR ITEM 27.

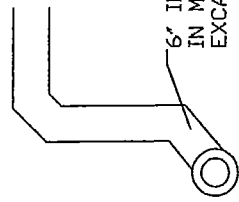

VERTICAL LATERAL RISER MEASUREMENT

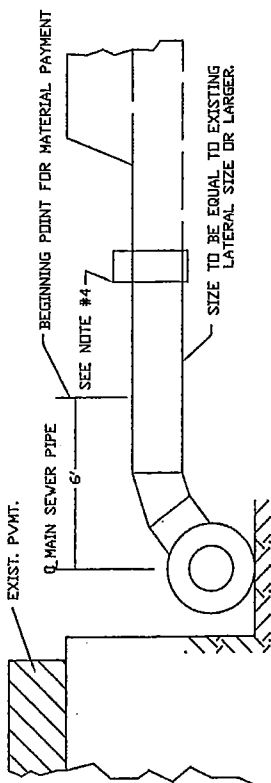

LATERAL SEWER REPAIR

TYPICAL TRENCH

MAXIMUM PAY WIDTH FOR PAVEMENT REMOVAL AND REPLACEMENT	
D	V
UP TO 12'-0"	6' - 0"
12'-0" TO 15'-0"	7' - 0"
15'-0" TO 20'-0"	8' - 0"

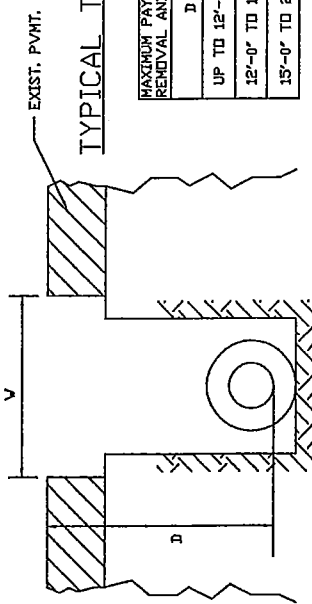

MAIN SEWER REPAIR

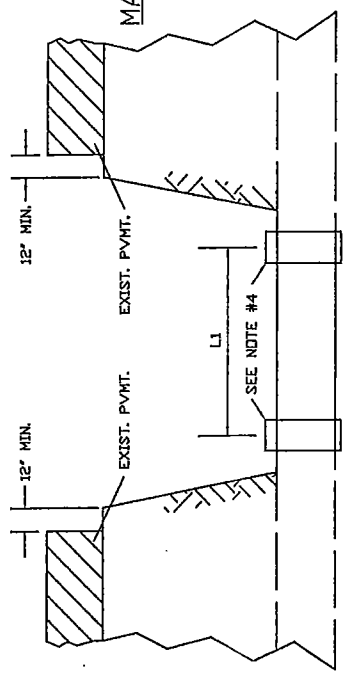

MAIN SEWER REPAIR

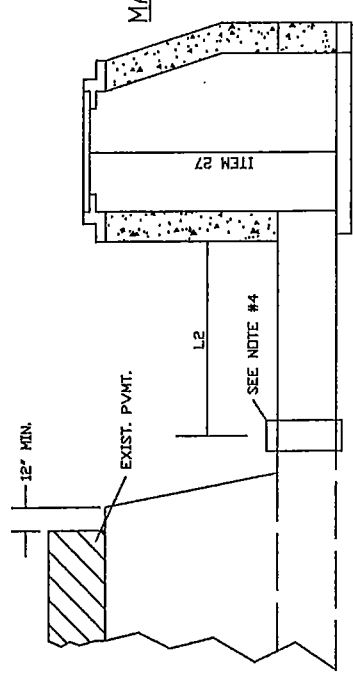

12/16/13	DR. BY	DATE	APPROVED CITY ENGINEER
1/31/14	CK. BY	DATE	1-604R
2/4/14	BY	DATE	REVISIONS
SANITARY STORM SEWER REPAIRS METHOD OF MEASUREMENT REVISED FOR 2014 SEWER REPAIR CONTRACT			

# MAINLINE SEWER REPAIR IN CONCRETE PAVEMENT

**PAY ITEMS:**

BID ITEM 1: 12x6  
72 S.F.  
8 S.Y.  
BID ITEM 2: 12 L.F.  
BID ITEM 18: 8 S.Y.

**MATERIAL:**

ACTUAL MATERIAL COST PLUS 15% FOR 5 L.F. OF 12" PVC PIPE AND FERNCOS AND FITTINGS  
ACTUAL MATERIAL COST PLUS 15% FOR 10 L.F. OF 6" LATERAL, FERNCOS AND FITTINGS

**EXCAVATION INCLUDES:**

6 L.F. OF 8" PVC PIPE  
5 L.F. OF 12" PVC PIPE  
16 L.F. OF 6" PVC LATERAL  
(6' LATERAL INCLUDED IN EXCAVATION:  
REMAINING 10' PAID MATERIAL PLUS 15%)  
WYE FITTINGS  
JOINTS, BENDS, FITTINGS, COUPLINGS  
SPECIAL BACKFILL, COMPACTED

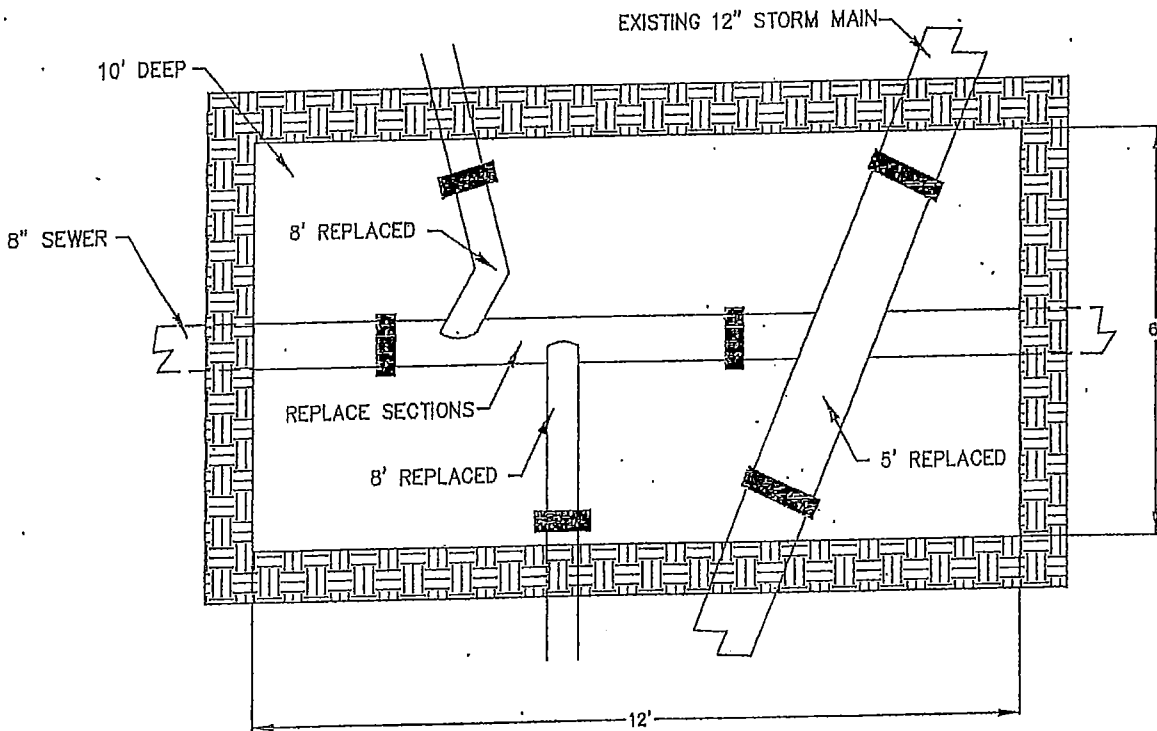

DWG. BY:		DATE:
--		DEC 2013
REV. NO.	REV. DATE	REV. BY
	JAN-31-14	

## EXISTING MAINLINE REPAIR PAY ITEM EXAMPLE

CITY OF ELYRIA  
DEPARTMENT OF ENGINEERING

SCALE:
NONE
STANDARD DRAWING NO.
STREET EXCAVATION:
1 OF 1

# WYE REPAIR IN ASPHALT PAVEMENT

**PAY ITEMS:**

- ITEM 2: 6 LF. 8" PVC PIPE, 8' DEEP
- ITEM 18: 6'x4'
- 24 SQ. FT
- 2.67 SQ. YDS.

**EXCAVATION INCLUDES:**

- 6 LIN. FT. 8" PVC PIPE
- 4 LF. 6" LATERAL PIPE
- WYE FITTINGS
- ALL NECESSARY APPURTENANCES, JOINTS, BENDS, FITTINGS
- SPECIAL BACKFILL, COMPACTED

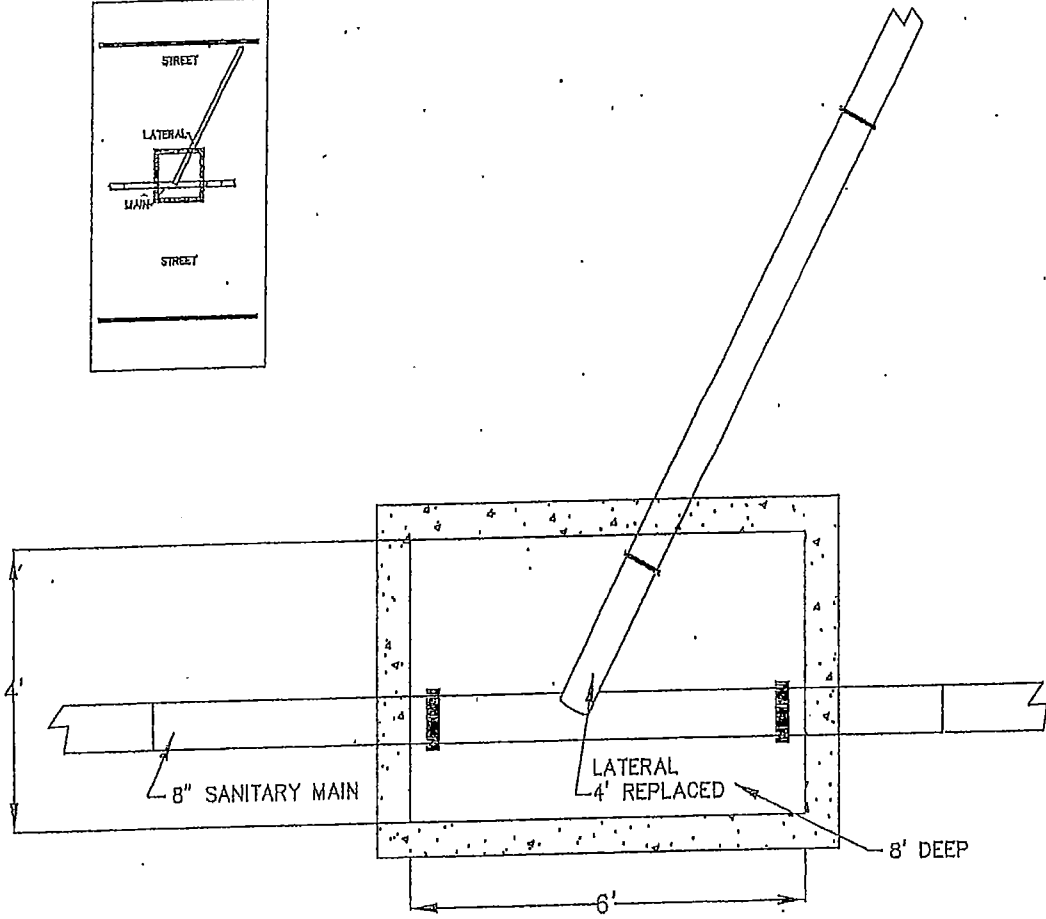
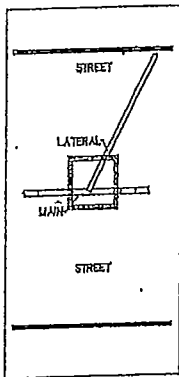

PLAN VIEW

WG. BY:	DATE:	
---	DEC 2013	
REV. NO.	REV. DATE	REV. BY
	2-3-2014	

**EXISTING WYE REPAIR**  
PAY ITEM EXAMPLE

CITY OF ELYRIA  
DEPARTMENT OF ENGINEERING

SCALE:
NONE
STANDARD DRAWING NO.
STREET EXCAVATION:
1 OF 1

# WYE REPAIR IN ASPHALT OVER CONCRETE PAVEMENT

**PAY ITEMS:**

- ITEM 1: 36 SQ. FT. (4X6 + 3X4)  
4 SQ. YDS.
- ITEM 3: 6 LF. 8" PVC PIPE, 11' DEEP
- ITEM 13: 3 LF. 6" LATERAL, 9' DEEP
- ITEM 18: 4 SQ. YDS.

**MATERIALS:**

ACTUAL MATERIAL PLUS 15% FOR 4 LF - 6" LATERAL AND FERNCOS AND FITTINGS

**EXCAVATION INCLUDES:**

- 6 LF. 8" PVC PIPE
- 13 LF. 6" PVC LATERAL (6 LF INCLUDED IN ORIGINAL EXCAVATION, 3 LF PAID WITH ITEM 13, 4 LF PAID ACTUAL MATERIAL PLUS 15%)
- WYE FITTINGS,
- ALL NECESSARY JOINTS, BENDS, FITTINGS
- SPECIAL BACKFILL, COMPACTED

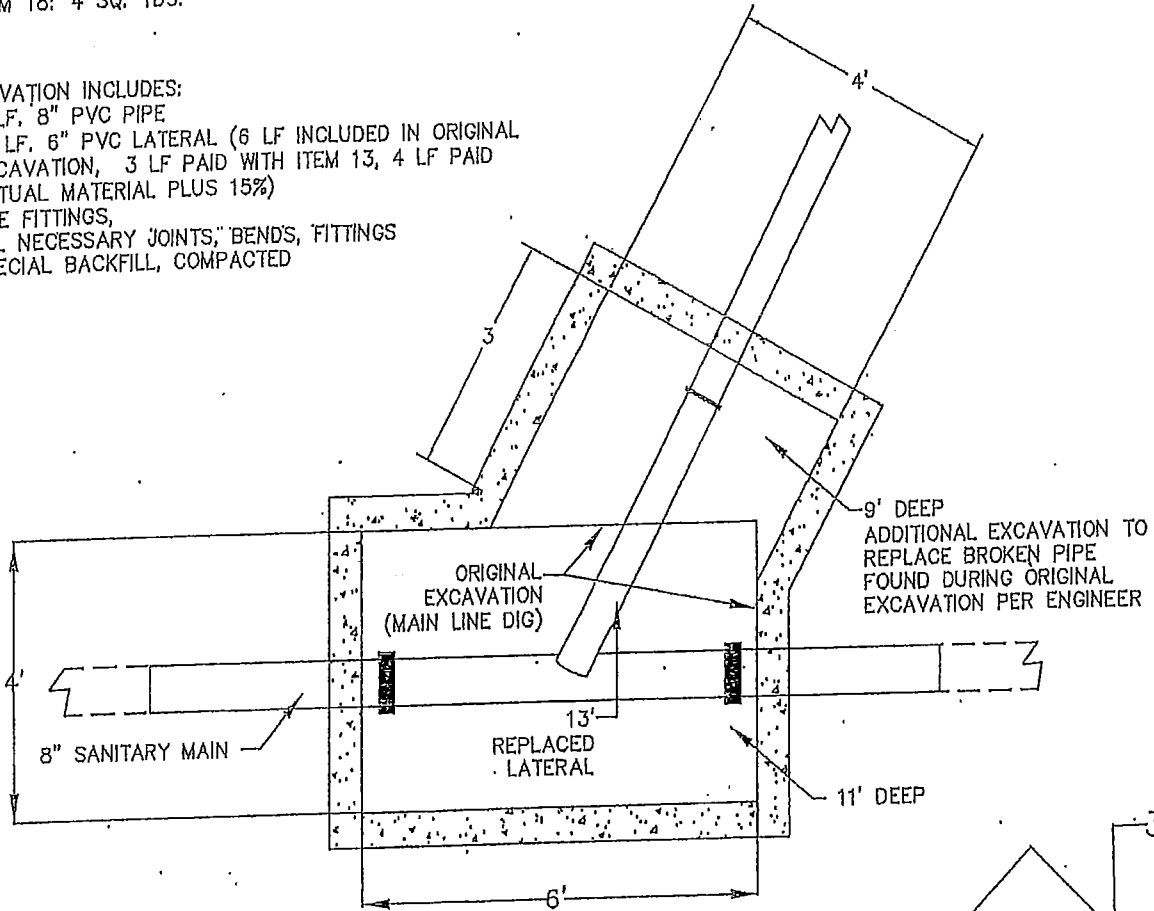

PLAN VIEW

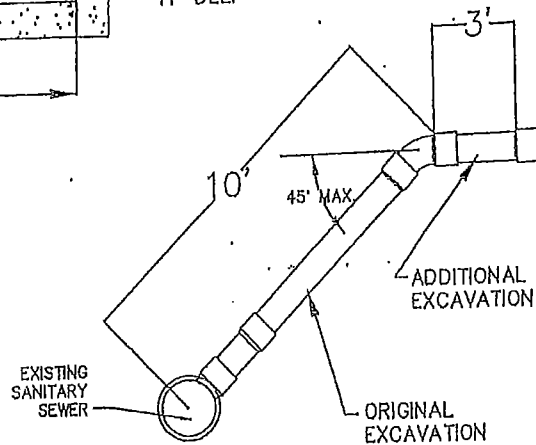
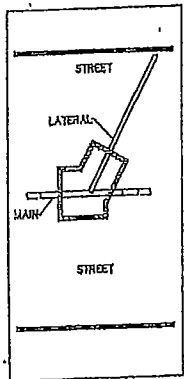

SECTION VIEW

WG. BY:	DATE:	
---	DEC 2013	
REV. NO.	REV. DATE	REV. BY
	JAN-31-14	

**EXISTING WYE REPAIR**  
PAY ITEM EXAMPLE

CITY OF ELYRIA  
DEPARTMENT OF ENGINEERING

SCALE:
NONE
STANDARD DRAWING NO.
STREET EXCAVATION:
1 OF 1

# WYE REPAIR

**PAY ITEMS:**

ITEM 1: 48 SQ. FT, 4'x12'  
5.33 SQ. YDS.

ITEM 3: 12 LIN. FT.

ITEM 18: 5.33 SQ. YDS

**MATERIAL:**

ACTUAL MATERIAL PLUS 15%  
FOR 5 L.F. - 6" LATERAL

**EXCAVATION INCLUDES:**

- 11 LIN. FT. 8" PVC PIPE
- WYE FITTINGS
- 11 LIN. FT. 6" PVC LATERAL PIPE
- ALL NECESSARY JOINTS, BENDS, FITTINGS
- SPECIAL BACKFILL, COMPACTED
- (FIRST 6 L.F. OF LATERAL INCLUDED IN EXCAVATION)

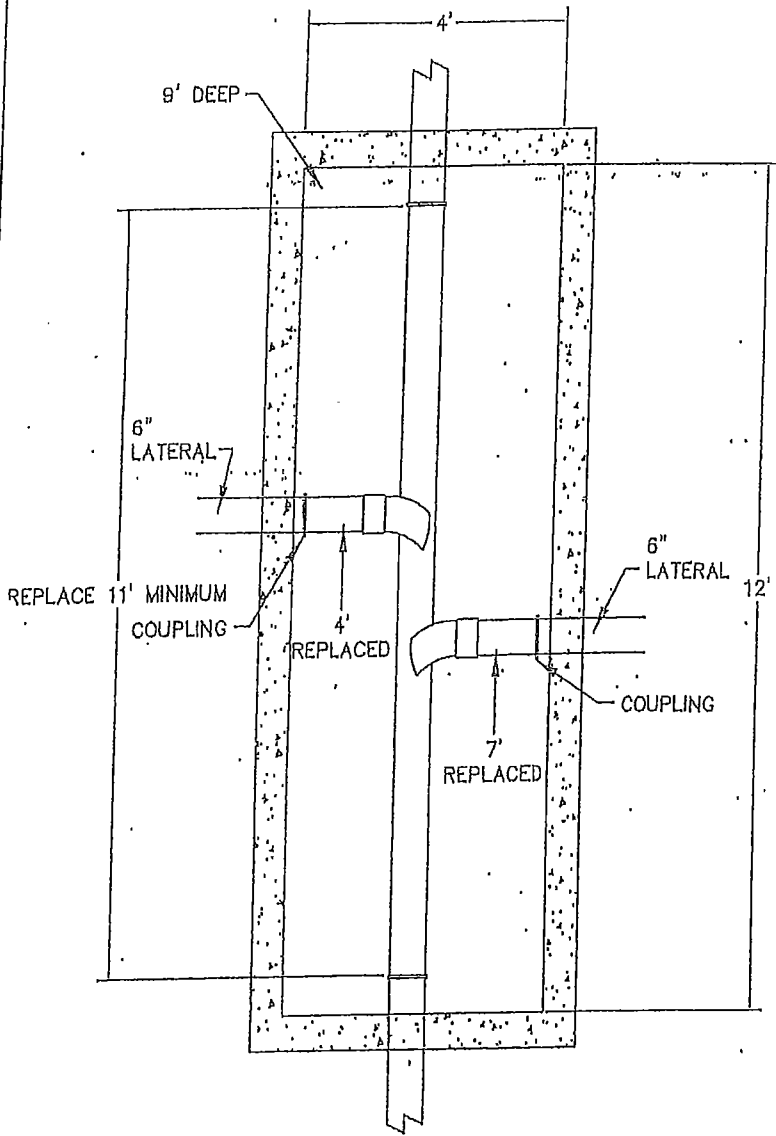

PLAN VIEW

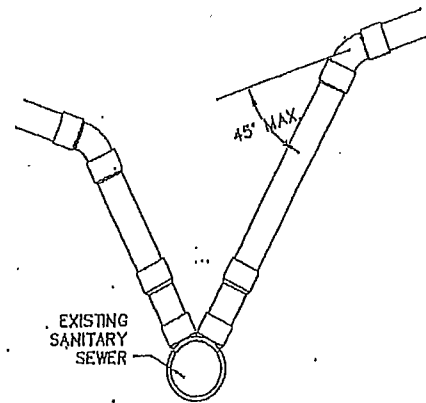

SECTION VIEW

DWG. BY:	DATE:	
--	JAN 2014	
REV. NO.	REV. DATE	REV. BY

<b>EXISTING WYE REPAIR</b>
PAY ITEM EXAMPLE
CITY OF ELYRIA DEPARTMENT OF ENGINEERING

SCALE:
NONE
STANDARD
DRAWING NO.
STREET EXCAVATION:
1 OF 1

# LATERAL REPAIR IN ASPHALT PAVEMENT

**PAY ITEMS:**

- ITEM 12: 13 LF LATERAL PIPE, 6' DEEP
- ITEM 18: 13'x4'
- 52 SQ. FT
- 5.78 SQ. YDS.

**EXCAVATION INCLUDES:**

- 12 LIN. FT. 6" PVC LATERAL PIPE
- ALL NECESSARY JOINTS, BENDS, FITTINGS
- SPECIAL: BACKFILL, COMPACTED

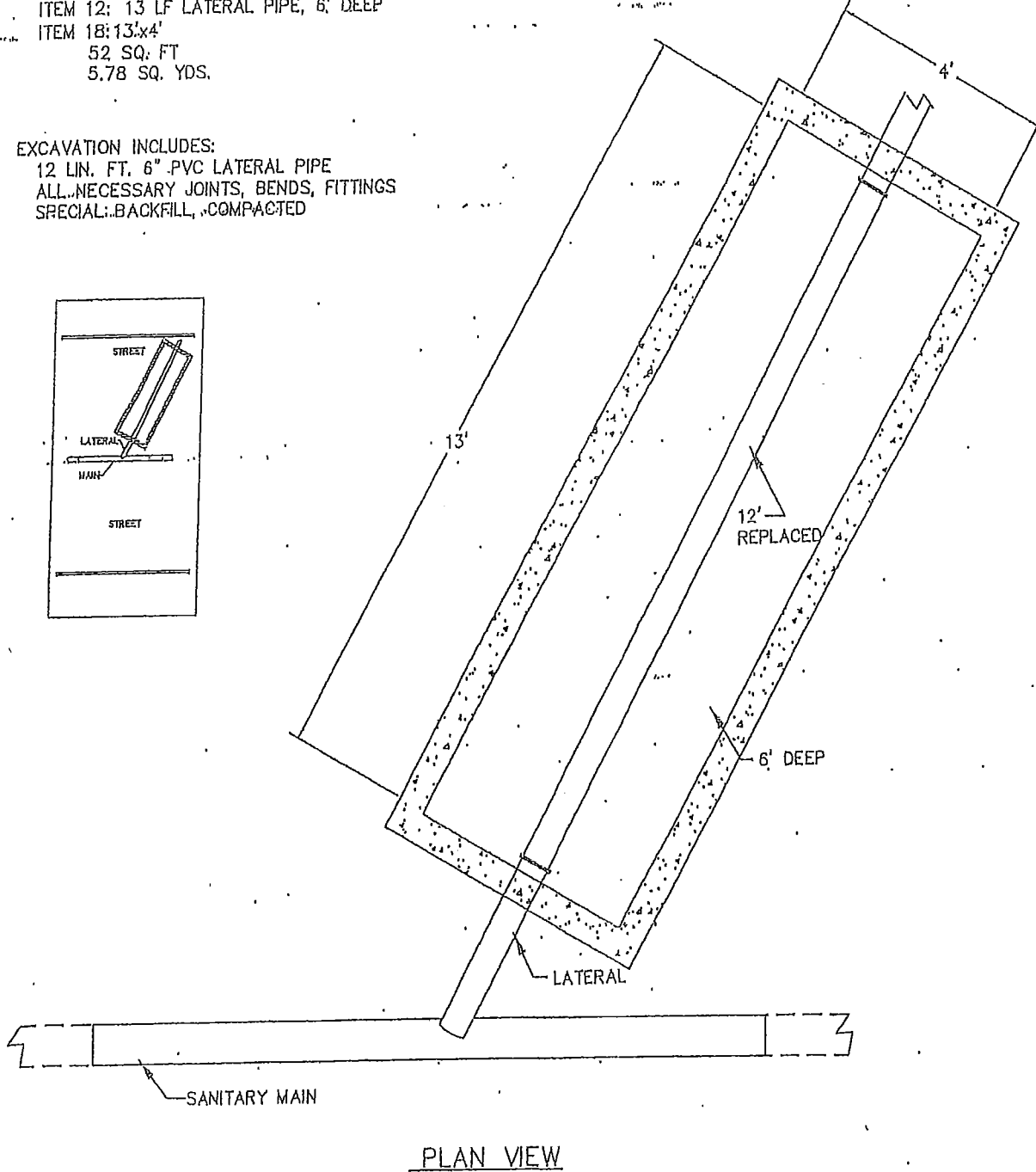
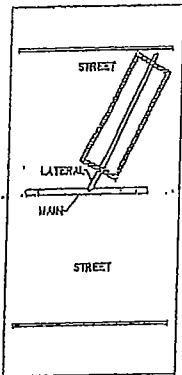

DWG. BY:	DATE:	
---	DEC 2013	
REV. NO.	REV. DATE	REV. BY

## EXISTING LATERAL LINE REPAIR PAY ITEM EXAMPLE

CITY OF ELYRIA  
DEPARTMENT OF ENGINEERING

SCALE:
NONE
STANDARD DRAWING NO.
STREET EXCAVATION:
1 OF 1

# MAINLINE REPAIR IN ASPHALT OVER CONCRETE PAVEMENT

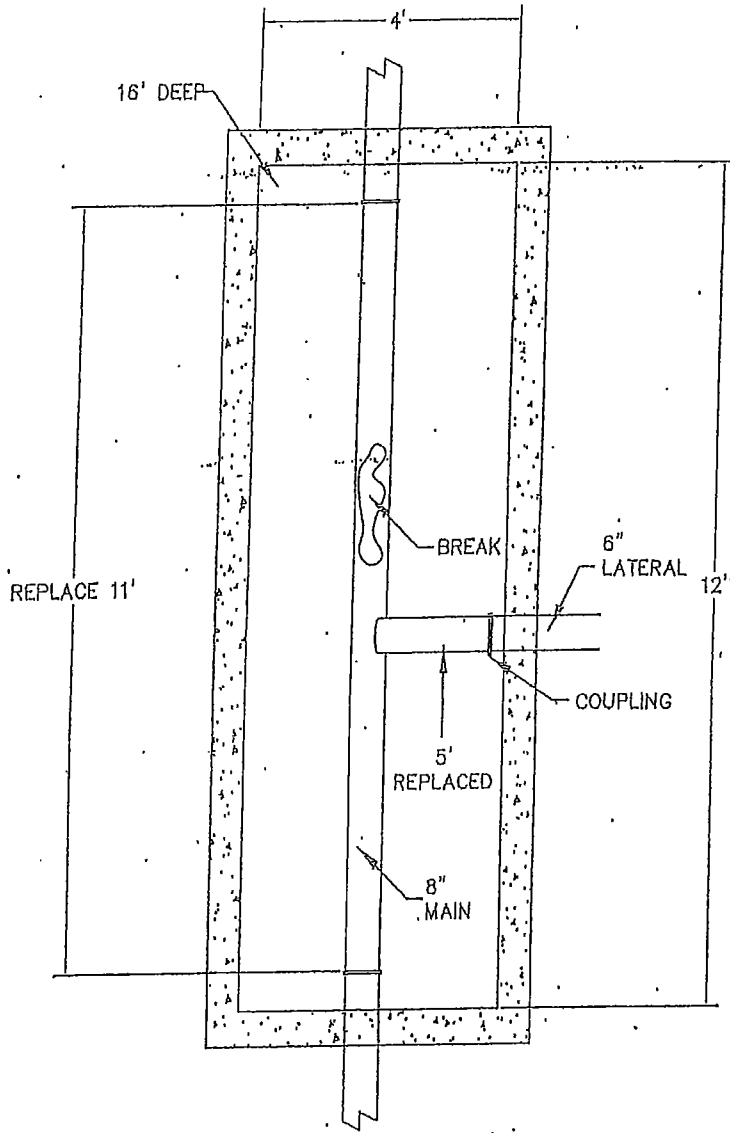

PLAN VIEW

PAY ITEMS: . . . . .  
 ITEM 1: 48 SQ. FT (4'x12")  
 5.33 SQ. YDS.  
 ITEM 3: 12 LIN. FT. 16' DEEP  
 ITEM 18: 5.33 SQ. YDS

EXCAVATION INCLUDES: . . . . .  
 11 LIN. FT. 8" PVC PIPE  
 WYE FITTING  
 5 LIN. FT. 6" PVC LATERAL PIPE \*  
 ALL NECESSARY JOINTS, BENDS, FITTINGS  
 SPECIAL BACKFILL, COMPACTED

\* FIRST 6 L.F. OF LATERAL PIPE  
 INCLUDED IN EXCAVATION.

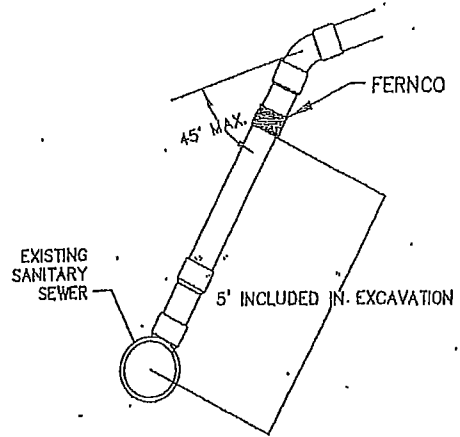

SECTION VIEW

DWG. BY:	DATE:
--	DEC 2013
REV. NO.	REV. DATE
	REV. BY

**EXISTING MAIN LINE REPAIR**  
 PAY ITEM EXAMPLE.

CITY OF ELYRIA  
 DEPARTMENT OF ENGINEERING

SCALE:
NONE
STANDARD
DRAWING NO.
STREET EXCAVATION:

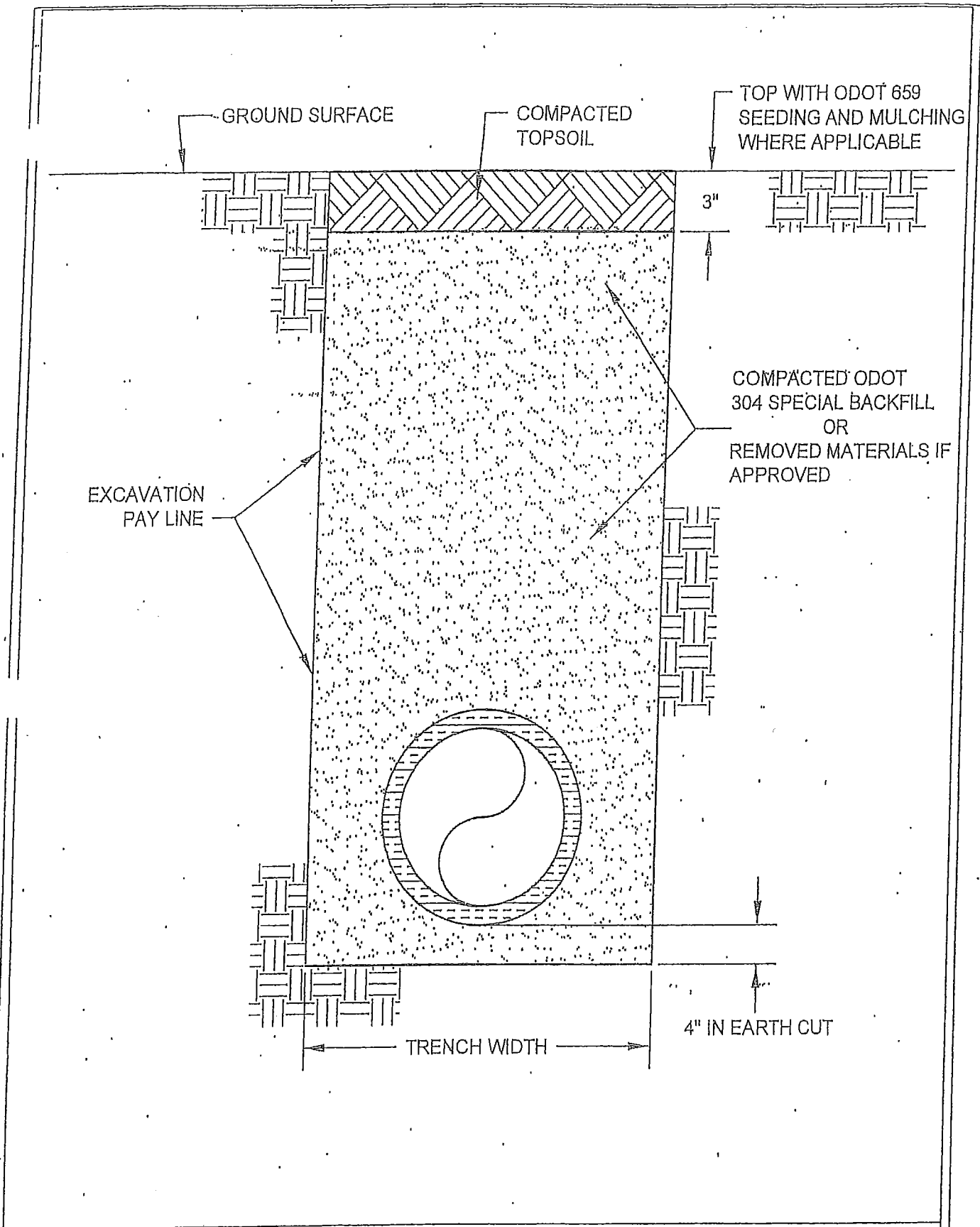

DWG. BY:		DATE:
--		DEC 2013
REV. NO.	REV. DATE	REV. BY

**TRENCH REPAIR SECTION  
IN GRASS AREAS**

CITY OF ELYRIA  
DEPARTMENT OF ENGINEERING SERVICES  
*Division of Engineering, Design and Construction*

SCALE:  
NONE  
STANDARD  
DRAWING NO.  
**TR-2**  
1 OF 1

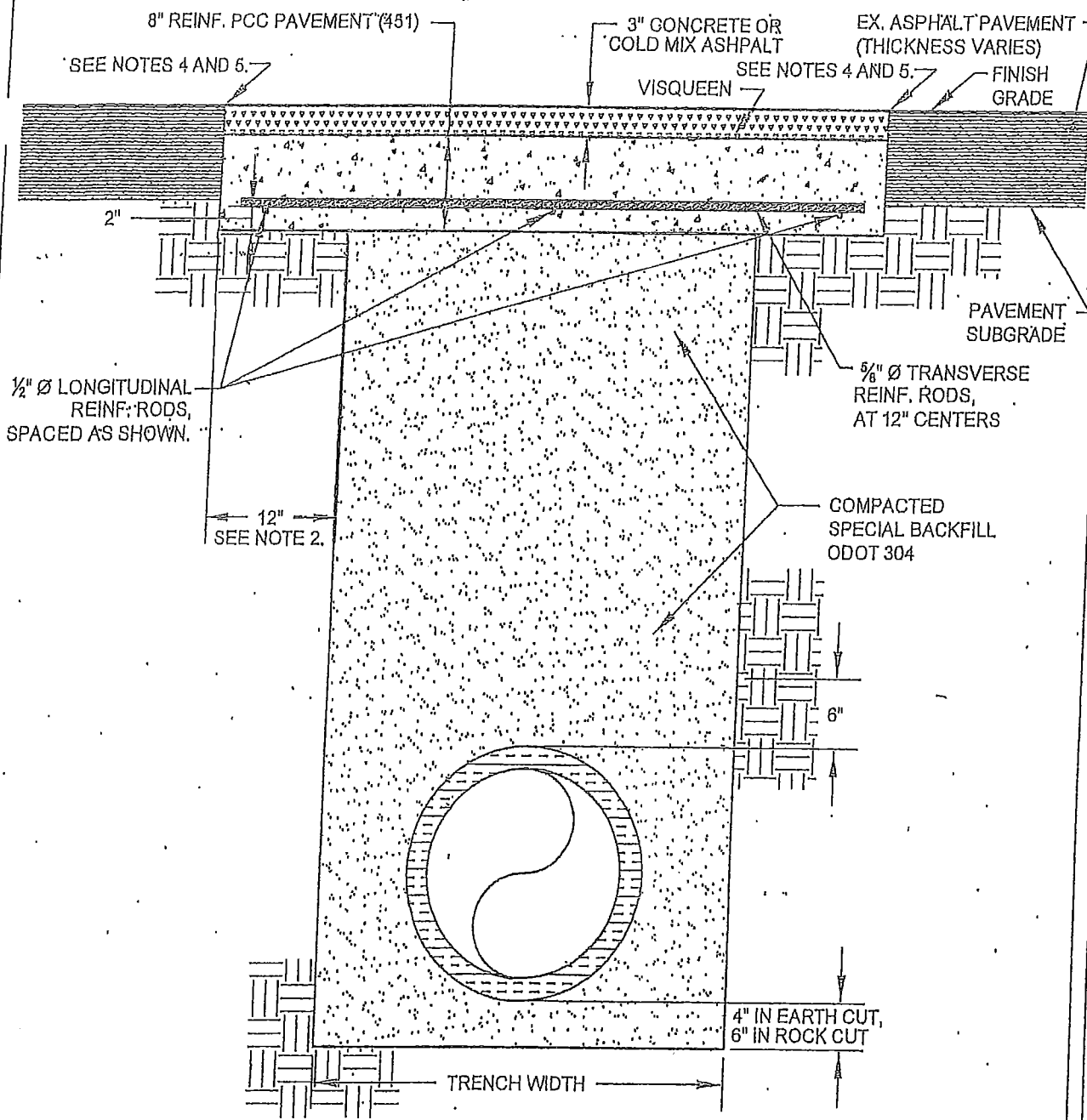

**NOTES:**

1. TEMPORARY WEARING SURFACE SHOULD ONLY BE INSTALLED WHEN INCLEMENT WEATHER DOES NOT PERMIT THE PROPER PERMANENT TRENCH REPAIR TO BE MADE.
2. WHEN TRENCH AND EXCAVATION IS IN AN EXISTING PAVED STREET, DRIVE APPROACH, OR OTHER PAVED SURFACE, REPLACE PAVEMENT A MINIMUM OF 12" ON EACH SIDE OF TRENCH, AS DIRECTED BY THE ENGINEER. HOOK BOLTS SHALL BE USED TO ANCHOR CONCRETE TRENCH CAP WITH EXISTING PAVEMENT
3. PAVEMENT SECTION SHALL BE AT LEAST EQUIVALENT TO EXISTING PAVEMENT, BUT IN NO CASE LESS THAN THAT SHOWN IN DETAIL.
4. DIAMOND SAW CUT EXISTING PAVEMENT AND RE-PAVE TO A CLEAN, STRAIGHT EDGE (TYP). DO NOT REMOVE PAVEMENT OUTSIDE OF THE TRENCH NEAT LINE UNTIL AFTER THE TRENCH HAS BEEN BACKFILLED. THE EXISTING PAVEMENT SHALL BE SAWED BEFORE REMOVING SO AS TO PRESERVE A NEAT LINE FOR THE ENTIRE LENGTH OF THE TRENCH ON EACH SIDE.
5. ALL VERTICAL EDGES OF EXISTING ASPHALT CONCRETE SHALL BE TACK COATED. SEAL JOINT WITH HOT ASPHALT CEMENT, FOR 448.

DWG. BY:		DATE:
---		DEC 2013
REV. NO.	REV. DATE	REV. BY

## TRENCH PAVING SECTION TEMPORARY WEARING SURFACE

CITY OF ELYRIA  
DEPARTMENT OF ENGINEERING SERVICES  
Division of Engineering, Design and Construction

SCALE:
NONE
STANDARD DRAWING NO.
<b>TR-5</b>
1 OF 1

TYPICAL TRENCH REPAIR  
IN EXISTING CONCRETE PAVEMENT

TYPICAL TRENCH REPAIR  
IN EXISTING ASPHALT PAVEMENT

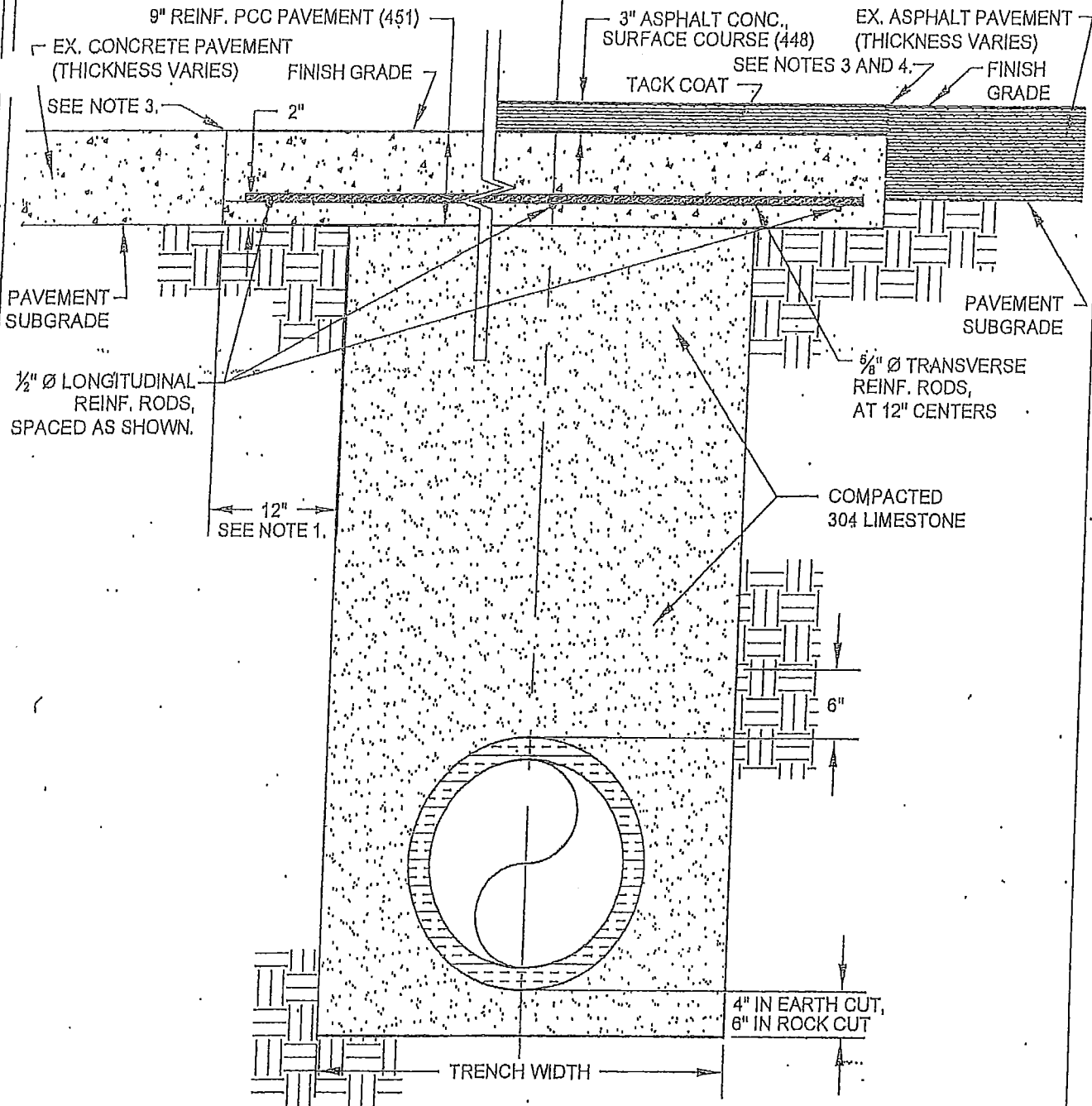

NOTES:

1. WHEN TRENCH AND EXCAVATION IS IN AN EXISTING PAVED STREET, DRIVE APPROACH, OR OTHER PAVED SURFACE, REPLACE PAVEMENT A MINIMUM OF 12" ON EACH SIDE OF TRENCH, AS DIRECTED BY THE ENGINEER. HOOK BOLTS SHALL BE USED TO ANCHOR CONCRETE TRENCH CAP WITH EXISTING PAVEMENT
2. PAVEMENT SECTION SHALL BE AT LEAST EQUIVALENT TO EXISTING PAVEMENT, BUT IN NO CASE LESS THAN THAT SHOWN IN DETAIL.
3. DIAMOND SAW CUT EXISTING PAVEMENT AND RE-PAVE TO A CLEAN, STRAIGHT EDGE (TYP.). DO NOT REMOVE PAVEMENT OUTSIDE OF THE TRENCH NEAT LINE UNTIL AFTER THE TRENCH HAS BEEN BACKFILLED. THE EXISTING CONCRETE SHALL BE SAWS BEFORE REMOVING SO AS TO PRESERVE A NEAT LINE FOR THE ENTIRE LENGTH OF THE TRENCH ON EACH SIDE.
4. ALL VERTICAL EDGES OF EXISTING ASPHALT CONCRETE SHALL BE TACK COATED. SEAL JOINT WITH HOT ASPHALT CEMENT, FOR 448.

DWG. BY:	DATE:	
--	DEC 2013	
REV. NO.	REV. DATE	REV. BY

TRENCH REPAIR SECTION  
IN EXISTING PAVEMENT

CITY OF ELYRIA  
DEPARTMENT OF ENGINEERING SERVICES  
Division of Engineering, Design and Construction

SCALE:
NONE
STANDARD
DRAWING NO.
TR-4

## Prevailing Wage Determination Cover Letter

**County:** LORAIN  
**Determination Date:** 04/11/2021  
**Expiration Date:** 07/11/2021

THE FOLLOWING PAGES ARE PREVAILING RATES OF WAGES ON PUBLIC IMPROVEMENTS FAIRLY ESTIMATED TO BE MORE THAN THE AMOUNT IN O.R.C. SEC. 4115.03 (b) (1) or (2), AS APPLICABLE.

Section 4115.05 provides, in part: "Where contracts are not awarded or construction undertaken within ninety days from the date of the establishment of the prevailing wages, there shall be a redetermination of the prevailing rate of wages before the contract is awarded." The expiration date of this wage schedule is listed above for your convenience only. This wage determination is not intended as a blanket determination to be used for all projects during this period without prior approval of this Department.

Section 4115.04, Ohio Revised Code provides, in part: "Such schedule of wages shall be attached to and made a part of the specifications for the work, and shall be printed on the bidding blanks where the work is done by contract..."

The contract between the letting authority and the successful bidder shall contain a statement requiring that mechanics and laborers be paid a prevailing rate of wage as required in Section 4115.06, Ohio Revised Code.

The contractor or subcontractor is required to file with the contracting public authority upon completion of the project and prior to final payment therefore an affidavit stating that he has fully complied with Chapter 4115 of the Ohio Revised Code.

The wage rates contained in this schedule are the "Prevailing Wages" as defined by Section 4115.03, Ohio Revised Code (the basic hourly rates plus certain fringe benefits). These rates and fringes shall be a minimum to be paid under a contract regulated by Chapter 4115 of the Ohio Revised Code by contractors and subcontractors. The prevailing wage rates contained in this schedule include the effective dates and wage rates currently on file. In cases where future effective dates are not included in this schedule, modifications to the wage schedule will be furnished to the Prevailing Wage Coordinator appointed by the public authority as soon as prevailing wage rates increases are received by this office.

"There shall be posted in a prominent and accessible place on the site of work a legible statement of the Schedule of Wage Rates specified in the contract to the various classifications of laborers, workmen, and mechanics employed, said statement to remain posted during the life of such contract." Section 4115.07, Ohio Revised Code.

Apprentices will be permitted to work only under a bona fide apprenticeship program if such program exists and if such program is registered with the Ohio Apprenticeship Council.

Section 4115.071 provides that no later than ten days before the first payment of wages is due to any employee of any contractor or subcontractor working on a contract regulated by Chapter 4115, Ohio Revised Code, the contracting public authority shall appoint one of his own employees to act as the prevailing wage coordinator for said contract. The duties of the prevailing wage coordinator are outlined in Section 4115.071 of the Ohio Revised Code.

Section 4115.05 provides for an escalator in the prevailing wage rate. Each time a new rate is established, that rate is required to be paid on all ongoing public improvement projects.

A further requirement of Section 4115.05 of the Ohio Revised Code is: "On the occasion of the first pay date under a contract, the contractor shall furnish each employee not covered by a collective bargaining agreement or understanding between employers and bona fide organizations of Labor with individual written notification of the job classification to which the employee is assigned, the prevailing wage determined to be applicable to that classification, separated into the hourly rate of pay and the fringe payments, and the identity of the prevailing wage Coordinator appointed by the public authority. The contractor or subcontractor shall furnish the same notification to each affected employee every time the job classification of the employee is changed."

Work performed in connection with the installation of modular furniture may be subject to prevailing wage.

**THIS PACKET IS NOT TO BE SEPARATED BUT IS TO REMAIN COMPLETE AS IT IS SUBMITTED TO YOU. (Reference guidelines and forms are included in this packet to be helpful in the compliance of the Prevailing Wage law.)**

wh1500





# Important Notice Prevailing Wage Threshold Levels

Before advertising for bids, contracting, or undertaking construction with its own forces, to construct a public improvement, the Public Authority shall have the Ohio Department of Commerce-Division of Industrial Compliance, Bureau of Wage and Hour Administration determine the prevailing rates of wages for workers employed on the public improvement. The wage determination must be included in the project specifications and printed on the bidding blanks where work is done by contract.

<b>“New” construction threshold for <i>Building Construction</i>:</b>	<b>\$250,000</b>
<b>“Reconstruction, enlargement, alteration, repair, remodeling, renovation, or painting” threshold level for <i>Building Construction</i>:</b>	<b>\$75,000</b>

## As of January 1, 2020:

<b>“New” construction that involves <i>roads, streets, alleys, sewers, ditches and other works connected to road or bridge construction</i> threshold level has been adjusted to:</b>	<b>\$93,292</b>
<b>“Reconstruction, enlargement, alteration, repair, remodeling, renovation, or painting” that involves <i>roads, streets, alleys, sewers, ditches and other works connected to road or bridge construction</i> threshold level has been adjusted to:</b>	<b>\$27,950</b>

- A) Thresholds are to be adjusted biennially by the Director of the Ohio Department of Commerce.
- B) Biennial adjustments to threshold levels are made according to the Building Cost for Skilled Labor Index published by McGraw-Hill’s Engineering News-Record, but may not increase or decrease more than 3% for any year.

If there are questions concerning this notification, please contact:

Ohio Department of Commerce  
 Division of Industrial Compliance  
 Bureau of Wage and Hour Administration  
 6606 Tussing Road, PO Box 4009  
 Reynoldsburg, Ohio 43068-9009  
 Phone: 614-644-2239  
 Fax: 614-728-8639  
[www.com.ohio.gov](http://www.com.ohio.gov)



## PREVAILING WAGE LAW

Wages And Hours On Public Works (Prevailing Wage)

ORC Chapter 4115: Wages And Hours On Public Works (Prevailing Wage)

If you are a public authority and wish this division to issue to you a determination as to the prevailing rates of wages called for by the public improvement in the locality where the work is to be performed, you may fill-out a request form on line here: [Prevailing Wage Request Form](#).

**Remember:** Filling out and submitting the Prevailing Wage Request Form informs us of your project information. Print this document out for your files prior to clicking the "Submit" button on the on-line form. The current date is automatically generated by the form and is in the upper right hand corner. If you mark the "Internet" choice in the "Method of delivery" box, no mailing will be sent to you as this indicates that you have or will download the wage rates from the web site.

### Accessing Prevailing Wage Rates

To gain free access to our Prevailing Wage Rate Database, click [here](#). You must enter information requested prior to gaining access. This database is primarily for Public Authorities, Unions, Contractors, and others who are in the process of complying with Ohio's prevailing wage laws on public projects.

### Access Registration for Prevailing Wage Rates.

The following information regarding Ohio's prevailing wage is supplied only as a guide. We suggest that for in-depth questions that you consult Ohio's prevailing wage law, codified in [ORC Chapter 4115: Wages And Hours On Public Works \(Prevailing Wage\)](#).

Ohio's prevailing wage law applies to construction projects undertaken by public authorities and requires that the public authorities pay the locally prevailing rate of wages to workers on the project.

Ohio's prevailing wage rate is determined by the Director of the Ohio Department of Commerce (DOC) and is the sum of the following:

The basic hourly rate of pay.

The rate of contribution irrevocably made by a contractor or subcontractor to a trustee or third person pursuant to a fund, plan, or program.

The rate of costs to the contractor or subcontractor which may be reasonably anticipated in providing fringe benefits.

These rates vary from locality to locality, and are based on collective bargaining agreements.

Every public authority authorized to contract for or construct with its own forces a public improvement, before advertising for bids or undertaking such construction with its own forces, shall have the Department of Commerce determine the prevailing rates of wages for the classes of work called for by the public improvement in the locality where such work is to be performed. This schedule of wages is to be attached to and made a part of the specifications for the work and shall be printed on the bidding blanks when the work is done by contract. Click on this link for more information regarding the duties of [Public Authorities and Prevailing Wage Coordinators](#).

Information on this site is believed to be accurate but is not guaranteed. The State of Ohio disclaims any liability for any errors or omissions.

[Ohio.Gov](#)

[Ohio Department of Commerce](#)

[Commerce Home](#) | [Press Room](#) | [Forms](#) | [CPI Policy](#) | [Privacy Statement](#) | [Public Records Request Policy](#) |

[Disclaimer](#) | [Employment](#) | [Contacts](#)



## PREVAILING WAGE CONTRACTOR RESPONSIBILITIES

This is a summary of prevailing wage contractors' responsibilities. For more detailed information please refer to Chapter 4115 of the Ohio Revised Code

### General Information

Ohio's prevailing wage laws apply to all public improvements financed in whole or in part by public funds when the total overall project cost is fairly estimated to be more than \$250,000 for new construction or \$75,000 for reconstruction, enlargement, alteration, repair, remodeling, renovation, or painting.

Ohio's prevailing wage laws apply to all public improvements financed in whole or in part by public funds when the total overall project cost is fairly estimated to be more than \$91,150 for new construction that involves roads, streets, alleys, sewers, ditches and other works connected to road or bridge construction or \$27,309 for reconstruction, enlargement, alteration, repair, remodeling, renovation, or painting of a public improvement that involves roads, streets, alleys, sewers, ditches and other works connected to road or bridge construction.

- a) Thresholds are to be adjusted biennially by the Administrator of Ohio Department of Commerce, Division of Industrial Compliance and Labor, Bureau of Wage and Hour Administration
- b) Biennial adjustments to threshold levels are made according to the Price Deflator for Construction Index, United States Department of Commerce, Bureau of the Census\*, but may not increase or decrease more than 3% for any year

### Penalties for violation

Violators are to be assessed the wages owed, plus a penalty of 100% of the wages owed.

### Intentional Violations

If an intentional violation is determined to have occurred, the contractor is prohibited from contracting directly or indirectly with any public authority for the construction of a public improvement. Intentional violation means "a willful, knowing, or deliberate disregard for any provision" of the prevailing wage law and includes but is not limited to the following actions:

- Intentional failure to submit payroll reports as required, or knowingly submitting false or erroneous reports.
- Intentional misclassification of employees for the purpose of reducing wages.
- Intentional misclassification of employees as independent contractors or as apprentices.
- Intentional failure to pay the prevailing wage.
- Intentional failure to comply with the allowable ratio of apprentices to skilled workers as required by the regulations established by Ohio Department of Commerce, Division of Industrial Compliance and Labor, Bureau of Wage and Hour Administration.
- Intentionally employing an officer, of a contractor or subcontractor, that is known to be prohibited from contracting, directly or indirectly, with a public authority.



**Department  
of Commerce**

Division of Industrial Compliance

**Responsibilities**

- A. Pay the prevailing rate of wages as shown in the wage rate schedules issued by the Ohio Department of Commerce, Division of Industrial Compliance and Labor, Bureau of Wage and Hour Administration, for the classification of work being performed.
1. Wage rate schedules include all modifications, corrections, escalations, or reductions to wage rates issued for the project.
  2. Overtime must be paid at time and one-half the employee's base hourly rate. Fringe benefits are paid at straight time rate for all hours including overtime.
  3. Prevailing wages must be paid in full without any deduction for food, lodging, transportation, use of tools, etc.; unless, the employee has voluntarily consented to these deductions in writing. The public authority and the Director of Ohio Department of Commerce, Division of Industrial Compliance and Labor, Bureau of Wage and Hour Administration - must approve these deductions as fair and reasonable. Consent and approval must be obtained before starting the project.
- B. Use of Apprentices and Helpers cannot exceed the ratios permitted in the wage rate schedules.
1. Apprentices must be registered with the U.S. Department of Labor Bureau of Apprenticeship and Training.
  2. Contractors must provide the Prevailing Wage Coordinator a copy of the Apprenticeship Agreement for each apprentice on the project.
- C. Keep full and accurate payroll records available for inspection by any authorized representative of the Ohio Department of Commerce, Division of Industrial Compliance, and Labor, Bureau of Wage and Hour Administration or the contracting public authority, including the Prevailing Wage Coordinator. Records should include but are not limited to:
1. Time cards, time sheets, daily work records, etc.
  2. Payroll ledger/journals and canceled checks/check register.
  3. Fringe benefit records must include program, address, account number, & canceled checks.
  4. Records made in connection with the public improvement must not be removed from the State for one year following the completion of the project.
  5. Out-of-State Corporations must submit to the Ohio Secretary of State the full name and address of their Statutory Agent in Ohio.
- D. Prevailing Wage Rate Schedule must be posted on the job site where it is accessible to all employees.
- E. Prior to submitting the initial payroll report, supply the Prevailing Wage Coordinator with your project dates to schedule reporting of your payrolls.
- F. Supply the Prevailing Wage Coordinator a list of all subcontractors including the name, address, and telephone number for each.
1. **Contractors are responsible for their subcontractors' compliance with requirements of Chapter 4115 of the Ohio Revised Code.**

Bureau of Wage and Hour Administration  
6606 Tussing Road  
Reynoldsburg, OH 43068-9099

614-644-2239  
Fax 614-728-8639  
TTY/TDD 800-750-0750  
com.ohio.gov

An Equal Opportunity Employer and Service Provider



**Department  
of Commerce**

Division of Industrial Compliance

- G. Before employees start work on the project, supply them with written notification of their job classification, prevailing wage rate, fringe benefit amounts, and the name of the Prevailing Wage Coordinator for the project. A copy of the completed signed notification should be submitted to Prevailing Wage Coordinator.
- H. Supply all subcontractors with the Prevailing Wage Rates and changes.
- I. Submit certified payrolls within two (2) weeks after the initial pay period. Payrolls must include the following information:
1. Employees' names, addresses, and social security numbers.
    - a. Corporate officers/owners/partners and any salaried personnel who do physical work on the project are considered employees. All rate and reporting requirements are applicable to these individuals.
  2. Employees' work classification.
    - a. Be specific about the laborers and/or operators (Group)
    - b. For all apprentices, show level/year and percent of journeyman's rate
  3. Hours worked on the project for each employee.
    - a. The number of hours worked in each day and the total number of hours worked each week.
  4. Hourly rate for each employee.
    - a. The minimum rate paid must be the wage rate for the appropriate classification. The Department's Wage Rate Schedule sets this rate.
    - b. All overtime worked is to be paid at time and one-half for all hours worked more than forty (40) per week.
  5. Where fringes are paid into a bona fide plan instead of cash, list each benefit and amount per hour paid to program for each employee.
    - a. When the amount contributed to the fringe benefit plan and the total number of hours worked by the employee on all projects for the year are documented, the hourly amount is calculated by dividing the total contribution of the employer by the total number of hours worked by the employee.
    - b. When the amount contributed to the fringe benefit is documented but not the total hours worked, the hourly amount is calculated by **dividing the total yearly contribution by 2080.**
  6. Gross amount earned on all projects during the pay period.
  7. Total deductions from employee's wages.
  8. Net amount paid.
- J. The reports shall be certified by the contractor, subcontractor, or duly appointed agent stating that the payroll is correct and complete; and that the wage rates shown are not less than those required by the O.R.C. 4115.
- K. Provide a Final Affidavit to the Prevailing Wage Coordinator upon the completion of the project.



**Many of our staff are teleworking to stop community spread of the coronavirus (COVID-19). Our office will also not be accepting walk-in customers. The Division is still operational, and customers will still be able to drop off plans, applications and other documents, but we ask that you first work through our web portal, where you can also submit payments. There are no convenience fees for online payment. Please call us at 614-644-2223 or email us at [IC@com.state.oh.us](mailto:IC@com.state.oh.us) with any questions. Thanks for your patience.**

## INSTRUCTIONS FOR PREPARING CERTIFIED PAYROLL REPORTS

### General

Contractors and subcontractors are required by law to submit certified payroll reports for work on projects covered by Ohio's Prevailing Wage Law. This form meets the reporting requirements established by Ohio Revised Code Chapter 4115. The use of this form is not mandatory, employers may submit their own forms provided that all of the required information is included. This form may be reproduced, or additional copies obtained from:

Ohio Department of Commerce Division of Industrial Compliance and Labor Bureau of Wage & Hour Administration 6606 Tussing Rd. P. O. Box 4009 Reynoldsburg, OH 43068-9009 Phone: (614) 644-2239

### Certified Payroll Heading

Employer name and address: Company's full name and address. Indicate if the company is a subcontractor, if so list the name of the General or Prime. Project: Name and location of the project, including county. Contracting Public Authority: Name and address of the contracting public authority. Week Ending: Month, day, and year for last day of reporting period. Payroll #: Indicates first, second, third, etc. payroll filed by the company for the project. Page indicator: number of pages included in the report. Project Number: Determined by the public authority. If there is no number leave blank.

### Information by Column

- 1. Employee Name, Address and Social Security number: This information must be provided for all employees that perform physical labor on the project. Corporate officers, partners, and salaried employees are considered employees and must be paid the prevailing rate. Individual sole proprietors do not have to pay themselves prevailing rate but must report their hours on the project.
- 2. Work Class: List classification of work actually performed by employee. If unsure of work classification, consult the Ohio department of Commerce, Wage and Hour Bureau. Employees working more than one classification should have separate line entries for each classification. Indicate what year/level for Apprentices. Be specific when using laborer and operator classifications; for example, Backhoe Operator or Asphalt Laborer.
- 3. Hours Worked, Day & Date: In the first row of column 3 enter days of pay period example; M T W T H F S S. The second row is for the date that corresponds with each day for the pay period. In the employee information section enter the number of hours worked on the prevailing wage project and which day the hours were worked. Separate rows are labeled for (ST) straight time hours and (OT) overtime hours. All hours worked after 40, must be paid at the appropriate overtime rate.
- 4. Project Total Hours : Total the hours entered for pay period.
- 5. Base Rate: Enter actual rate per hour paid to the employee. The overtime hourly rate is time and one-half the base rate listed in the prevailing wage schedule plus fringe benefits at straight time rate. The prevailing wage schedule lists the base rate plus fringe benefit amounts. These amounts added together equal the total prevailing wage rate. Employers must pay this total amount in one of three ways.
  - Total rate may be paid in entirety in the base rate to the employee; in which case, the cash designation will be checked for fringe benefits.
  - Total rate may be paid as listed in prevailing wage rate schedule with total fringe amounts paid approved plans.
  - Total rate may be paid with a combination of base rate and fringe payments to approved plans in amounts other than those listed in schedule.
- 6. Project Gross: Enter total gross wages earned on the project for straight time and overtime. Project hours X base rate should equal project gross.
- 7. Fringes: If fringe benefits are paid in the hourly base rate, indicate this by marking the cash space. If fringe benefits are paid to approved plans as listed in the prevailing wage rate schedule, mark the space Approved Plans. If fringe benefits are paid partially in the base rate and partially to approved plans, mark the space Cash & Approved plans. List the hourly amount paid to approved plans for each fringe. If payments are not made on a per hour basis, calculate the hourly fringe credit by dividing the yearly employer contribution by the lesser of: hours actually worked in the year (these must be documented) or 2080. Fringe benefits include: Employer's share of health insurance,

life insurance, retirement plan, bonus/profit sharing, sick pay, holiday pay, personal leave, vacation, and education/training programs.

- 8. Total Hours All Jobs: Total all hours worked during the pay period including non-prevailing wage jobs.
- 9. Total Gross All Jobs: Gross amount earned in the pay period for all hours worked.
- 10. Self explanatory.
- 11. Self explanatory.
- 12. Self explanatory.

[COM](#) | [Confidentiality Statement](#) | [Privacy Statement](#) | [News Room](#) | [Public Records Request Policy](#) | [Disclaimer](#)

#### CONTACT US

Division of Industrial Compliance & Labor  
6606 Tussing Road  
Reynoldsburg, OH 43068

Phone 614.644.2223  
Fax 614.644.2618  
Email [IC@com.state.oh.us](mailto:IC@com.state.oh.us)

Webmaster  
Contact the Webmaster for Questions  
or Comments on the Website:  
[webmaster@com.state.oh.us](mailto:webmaster@com.state.oh.us)

#### CONNECT WITH US



#### LOOKUP SERVICES

Registered Contractor List  
Boiler Information Database  
Building Code Compliance Electronic Plan  
Submission  
Board Of Building Appeals Case Lookup  
Elevator Database Lookup

#### RESOURCES

Federal Wage and Hour  
U.S. Consumer Product Safety  
Commission  
National Electric, Fire Alarm and Sprinkler  
Codes  
Minor Labor Law Poster  
2017 Minimum Wage Poster  
2018 Minimum Wage Poster

#### ABOUT INDUSTRIAL COMPLIANCE

Director Sheryl Maxfield  
Superintendent Geoff Eaton

[com.ohio.gov](http://com.ohio.gov)



Affidavit of Compliance

Prevailing Wages

I, \_\_\_\_\_ (Name of person signing affidavit) (Title)

do hereby certify that the wages paid to all employees of

\_\_\_\_\_ (Company Name)

for all hours worked on the

\_\_\_\_\_ (Project name and location)

project, during the period from \_\_\_\_\_ to \_\_\_\_\_ are in (Project Dates)

compliance with prevailing wage requirements of Chapter 4115 of the Ohio Revised Code. I further certify that no rebates or deductions have been or will be made, directly or indirectly, from any wages paid in connection with this project, other than those provided by law.

\_\_\_\_\_ (Signature of Officer or Agent)

Sworn to and subscribed in my presence this \_\_\_\_\_ day of \_\_\_\_\_, 20\_\_\_\_\_.

\_\_\_\_\_ (Notary Public)

The above affidavit must be executed and sworn to by the officer or agent of the contractor or subcontractor who supervises the payment of employees. This affidavit must be submitted to the owner (public authority) before the surety is released or final payment due under the terms of the contract is made.







## Certified Payroll Report - Instructions

### State of Ohio Standard Forms for Public Facility Construction

This Certified Payroll Report was created in Excel Version 14.0.6112.5000 (32-bit), part of Microsoft Office Professional 2010. There are two tabs that comprise a complete Certified Payroll Report that complies with Section 4115.071 of the Ohio Revised Code. Part A may be produced in response to a public records request without the need for redacting each Worker's Social Security Number in order to protect sensitive personal information. Part B shall be produced in response to a request from the Bureau of Wage and Hour Administration of the Department of Commerce.

**EMPLOYER NAME AND ADDRESS:** Enter the company's full name and address. Indicate if the company is a Subcontractor in the space below, if so list the name of the General or Prime Contractor. Prime Contractor includes a Construction Manager at Risk or a Design-Build firm.

**PROJECT NAME AND LOCATION:** Enter the name and location of the Project, including the county or counties where the Project is located.

**CONTRACTING AUTHORITY:** Enter the name and address of the public authority responsible for maintaining prevailing wage records. This may be the Project Owner.

**WEEK ENDING:** Indicate month, day, and year for last day of reporting period.

**PAYROLL NUMBER:** Indicate first, second, third, etc. payroll filed by the company for the project.

**PAGE:** Indicate number of pages included in the report.

**PROJECT / CONTRACT NUMBER:** Indicate the Project number or Contract number determined by the public authority. If there is no number leave blank.

**1. NAME AND INDIVIDUAL IDENTIFYING NUMBER OF WORKER:** Enter the name and a unique number for each employee. The full name, social security number, and address may be provided on Part B, which must be provided with each report to be considered valid. This information must be provided for all employees that perform physical labor on the Project. Corporate officers, partners, and salaried employees are considered employees and must be paid the prevailing rate. Individual sole proprietors do not have to pay themselves prevailing rate but must report their hours on the Project.

**2. WORK CLASSIFICATION:** List classification of work actually performed by employee. If unsure of work classification, consult the Ohio Department of Commerce, Wage and Hour Bureau. Employees working more than one classification should have separate line entries for each classification. Indicate what year/level for Apprentices. Be specific when using laborer and operator classifications; for example, Backhoe Operator or Asphalt Laborer.

**3. RACE AND SEX:** Provide the race and sex of each worker. This information is requested to facilitate review by the Construction Compliance Unit of the Equal Opportunity Division in the Ohio Department of Administrative Services pursuant to Chapter 123:2 of the Ohio Administrative Code. This information is not required by Chapter 4115 of the Ohio Revised Code.

**4. HOURS WORKED - DAY AND DATE:** In the first row of column 4 enter the days of the pay period. For example: S M T W T H F S. The second row is for the date that corresponds with each day for the pay period. In the employee information section enter the number of hours worked on the prevailing wage Project and which day(s) the hours were worked. Separate rows are labeled for (ST) straight time hours and (OT) overtime hours. All hours worked beyond 40 hours must be paid at the appropriate overtime rate.

**5. TOTAL PROJECT HOURS:** Total the hours entered for the pay period.

**6. BASE WAGE RATE:** Enter actual rate per hour paid to the employee. The overtime hourly rate is time and one-half the base rate listed in the prevailing wage schedule plus fringe benefits at straight time rate. The prevailing wage schedule lists the base rate plus fringe benefit amounts. These amounts added together equal the total prevailing wage rate. Employers must pay this total amount in one of three ways: (1) total rate may be paid in entirety in the base rate to the employee; in which case, the cash designation will be checked for fringe benefits; (2) total rate may be paid as listed in prevailing wage rate schedule with total fringe amounts paid approved plans; or (3) total rate may be paid with a combination of base rate and fringe payments to approved plans in amounts other than those listed in schedule.

**7. PROJECT GROSS:** Enter total gross wages earned on the Project for straight time and overtime. Project hours multiplied by base rate should equal the Project gross.

**8. FRINGES:** If fringe benefits are paid in the hourly base rate, indicate this by marking the cash space. If fringe benefits are paid to approved plans as listed in the prevailing wage rate schedule, mark the space for Approved Plans. If fringe benefits are paid partially in the base rate and partially to approved plans, mark the space for Cash & Approved plans. List the hourly amount paid to approved plans for each fringe. If payments are not made on a per-hour basis, calculate the hourly fringe credit by dividing the yearly employer contribution by the lesser of hours actually worked in the year (these must be documented) or 2080. Fringe benefits include: Employer's share of health insurance, life insurance, retirement plan, bonus/profit sharing, sick pay, holiday pay, personal leave, vacation, and education/training programs.

**9. TOTAL HOURS ALL JOBS:** Total all hours worked during the pay period including non-prevailing wage jobs.

**10. TOTAL GROSS ALL JOBS:** Gross amount earned in the pay period for all hours worked.

ITEMS 11., 12., AND 13. ARE SELF-EXPLANATORY

\*For Public Records Requests, redact Social Security Numbers.

\*Attach additional pages as necessary.

\*If Subcontractor, provide Contractor name in space provided.

End of Exhibit

# Prevailing Wage Rate Skilled Crafts

Name of Union: Asbestos Local 207 OH

Change # : LCN01-2018fbLoc207OH

Craft : Asbestos Worker Effective Date : 08/23/2018 Last Posted : 08/23/2018

	BHR	Fringe Benefit Payments						Irrevocable Fund		Total PWR	Overtime Rate
		H&W	Pension	App Tr.	Vac.	Annuity	Other	LECET (*)	MISC (*)		
Classification											
Asbestos Abatement	\$25.50	\$7.25	\$6.45	\$0.65	\$0.00	\$0.00	\$0.07	\$0.00	\$0.00	\$39.92	\$52.67
Trainee	\$16.50	\$7.25	\$1.50	\$0.65	\$0.00	\$0.00	\$0.07	\$0.00	\$0.00	\$25.97	\$34.22

**Special Calculation Note :**

**Ratio :**

3 Journeymen to 1 Trainee

**Jurisdiction ( \* denotes special jurisdictional note ) :**

ADAMS, ASHLAND, ASHTABULA\*, ATHENS, AUGLAIZE, BROWN, BUTLER\*, CARROLL, CHAMPAIGN, CLARK, CLERMONT, CLINTON, COLUMBIANA, COSHOCTON, CRAWFORD, CUYAHOGA, DARKE, DELAWARE, FAIRFIELD, FAYETTE, FRANKLIN, GEAUGA, GREENE, GUERNSEY, HAMILTON, HARDIN, HARRISON, HIGHLAND, HOCKING, HOLMES, HURON, KNOX, LAKE, LICKING, LOGAN, LORAIN, MADISON, MAHONING, MARION, MEDINA, MIAMI, MONTGOMERY, MORGAN, MORROW, MUSKINGUM, NOBLE, PERRY, PICKAWAY, PORTAGE, PREBLE, RICHLAND, ROSS, SHELBY, STARK, SUMMIT, TRUMBULL, TUSCARAWAS, UNION, VINTON, WARREN\*, WAYNE

**Special Jurisdictional Note :** Butler County:( townships of Fairfield,Hanover,Liberty,Milford,Morgan,Oxford,Ripley,Ross,StClair,Union & Wayne.) (Lemon & Madison) Warren County: (townships of: Deerfield, Hamilton, Harlan, Salem, Union & Washington). ( Clear Creek, Franklin, Mossie, Turtle Creek & Wayney). Ashtabula County: (post offices & townships of Ashtabula, Austinburg, Geneva, Harperfield, Jefferson, Plymouth & Saybrook) (townships of Andover, Cherry Valley, Colbrook, Canneaut, Denmark, Dorset, East Orwell, Hartsgrove, Kingville, Lenox, Monroe,Morgan,New Lyme,North Kingsville, Orwell, Pierpoint, Richmond Rock Creek, Rome, Sheffield, Trumbull, Wayne, Williamsfield & Windsor) Erie County:(post offices & townships of Berlin, Berlin Heights,Birmingham,Florence ,Huron, Milan, Shinrock & Vermilion)

**Details :**

Asbestos & lead paint abatement including, but not limited to the removal or encapsulation of asbestos & lead paint, all work in conjunction with the preparation of the removal of same & all work in conjunction with the

clean up after said removal. The removal of all insulation materials, whether they contain asbestos or not, from mechanical systems (pipes, boilers, ducts, flues, breaching, etc.) is recognized as being the exclusive work of the Asbestos Abatement Workers.

On all mechanical systems (pipes, boilers, ducts, flues, breaching, etc.) that are going to be demolished, the removal of all insulating materials whether they contain asbestos or not shall be the exclusive work of the Laborers.

An Abatement Journeyman is anyone who has more than 300 hours in the Asbestos Abatement field.

# Prevailing Wage Rate Skilled Crafts

**Name of Union: Asbestos Local 3 Heat & Frost Insulators**

**Change # : LCN01-2020fbLoc3**

**Craft : Asbestos Worker Effective Date : 08/01/2020 Last Posted : 07/30/2020**

	BHR		Fringe Benefit Payments					Irrevocable Fund		Total PWR	Overtime Rate	
			H&W	Pension	App Tr.	Vac.	Annuity	Other	LECET (*)			MISC (*)
Classification												
Asbestos Insulation Worker	\$39.08		\$13.35	\$10.00	\$0.00	\$0.00	\$0.00	\$0.00	\$0.00	\$0.00	\$62.43	\$81.97
Fire Stop Specialist	\$39.08		\$13.35	\$10.00	\$0.00	\$0.00	\$0.00	\$0.00	\$0.00	\$0.00	\$62.43	\$81.97
Fire Stop Technician	\$32.59		\$13.35	\$4.00	\$0.00	\$0.00	\$0.00	\$0.00	\$0.00	\$0.00	\$49.94	\$66.24
Apprentice	Percent											
1st year	51.15	\$19.99	\$13.35	\$1.00	\$0.00	\$0.00	\$0.00	\$0.00	\$0.00	\$0.00	\$34.34	\$44.33
2nd year	64.56	\$25.23	\$13.35	\$2.00	\$0.00	\$0.00	\$0.00	\$0.00	\$0.00	\$0.00	\$40.58	\$53.20
3rd year	69.99	\$27.35	\$13.35	\$3.00	\$0.00	\$0.00	\$0.00	\$0.00	\$0.00	\$0.00	\$43.70	\$57.38
4th year	83.39	\$32.59	\$13.35	\$4.00	\$0.00	\$0.00	\$0.00	\$0.00	\$0.00	\$0.00	\$49.94	\$66.23

**Special Calculation Note :** There are no special calculations for this classification.

**Ratio :**

3 Journeymen to 1 Apprentice per shop

**Jurisdiction ( \* denotes special jurisdictional note ) :**

ASHTABULA\*, CUYAHOGA, ERIE\*, GEAUGA, HURON, LAKE, LORAIN

**Special Jurisdictional Note :** Ashtabula (the townships of Ashtabula, Austinburg, Geneva, Jefferson, Plymouth & Saybrook), Lake, Geauga, Cuyahoga, Lorain, Huron, Erie (to Sandusky limits). The counties of Ashland, Coshocton, Holmes, Medina, Portage, Richland, Stark, Tuscarawas, Wayne, Summit, Harrison, Carroll, Columbiana, Mahoning & Trumbull & the remainder of Ashtabula will be considered open counties on a 90 day basis automatically renewable unless revoked by the Union upon 15-day written notice to the employers.

**Details :**

Mechanics & apprentices engaged in the manufacture, fabrication, assembling, molding, handling, erection, spraying, pouring, mixing, hanging, clean-up, preparation, application, adjusting, alteration, repairing, dismantling, reconditioning, testing & maintenance of Heat & Frost Insulation such as Magnesia, Asbestos, Hair Felt, Wool Felt, Cork, Mineral Wool, Infusorial Earth, Mercerized Silk, Flax, Fiber, Fire Felt, Asbestos Paper, Asbestos Curtain, Asbestos Millboard, Fiberglass, Foam glass, Styrofoam, Polyurethane, fire stopping, smoke stopping, all recyclable material, soundproofing, all penetrations, any flexible or rigid fireproofing, all jacketing systems including metal, lead, and PVC or other material.

# Prevailing Wage Rate Skilled Crafts

Name of Union: Boilermaker Local 744

Change # : LCNO1-2019fbLoc744

Craft : Boilermaker Effective Date : 04/03/2019 Last Posted : 04/03/2019

	BHR		Fringe Benefit Payments						Irrevocable Fund		Total PWR	Overtime Rate
			H&W	Pension	App Tr.	Vac.	Annuity	Other	LECET (*)	MISC (*)		
Classification												
Boilermaker	\$38.05		\$7.07	\$16.07	\$0.74	\$0.00	\$5.08	\$0.75	\$0.00	\$0.00	\$67.76	\$86.78
Apprentice	Percent											
1st 6 months	70.02	\$26.64	\$7.07	\$16.07	\$0.74	\$0.00	\$5.08	\$0.75	\$0.00	\$0.00	\$56.35	\$69.67
2nd 6 months	72.52	\$27.59	\$7.07	\$16.07	\$0.74	\$0.00	\$5.08	\$0.75	\$0.00	\$0.00	\$57.30	\$71.10
3rd 6 months	75.00	\$28.54	\$7.07	\$16.07	\$0.74	\$0.00	\$5.08	\$0.75	\$0.00	\$0.00	\$58.25	\$72.52
4th 6 months	77.51	\$29.49	\$7.07	\$16.07	\$0.74	\$0.00	\$5.08	\$0.75	\$0.00	\$0.00	\$59.20	\$73.95
5th 6 months	80.00	\$30.44	\$7.07	\$16.07	\$0.74	\$0.00	\$5.08	\$0.75	\$0.00	\$0.00	\$60.15	\$75.37
6th 6 months	85.03	\$32.35	\$7.07	\$16.07	\$0.74	\$0.00	\$5.08	\$0.75	\$0.00	\$0.00	\$62.06	\$78.24
7th 6 months	90.00	\$34.25	\$7.07	\$16.07	\$0.74	\$0.00	\$5.08	\$0.75	\$0.00	\$0.00	\$63.96	\$81.08
8th 6 months	95.00	\$36.15	\$7.07	\$16.07	\$0.74	\$0.00	\$5.08	\$0.75	\$0.00	\$0.00	\$65.86	\$83.93
Helper	60.00	\$22.83	\$7.07	\$16.07	\$0.74	\$0.00	\$5.08	\$0.75	\$0.00	\$0.00	\$52.54	\$63.96

**Special Calculation Note :** Other is Supplemental Health

**Ratio :**

5 Journeymen to 1 Apprentice to 1 Helper

**Jurisdiction ( \* denotes special jurisdictional note ) :**

ASHTABULA, CARROLL, COSHOCTON,  
CUYAHOGA, GEAUGA, HARRISON, HOLMES,  
LAKE, LORAIN, MAHONING, MEDINA,  
PORTAGE, STARK, SUMMIT, TRUMBULL,  
TUSCARAWAS, WAYNE

**Special Jurisdictional Note :**

**Details :**

# Prevailing Wage Rate Skilled Crafts

Name of Union: Bricklayer Local 36 Zone 1 Tile Finisher

Change # : LCN01-2021fbLoc5

Craft : Bricklayer Effective Date : 05/01/2021 Last Posted : 04/28/2021

	BHR		Fringe Benefit Payments					Irrevocable Fund		Total PWR	Overtime Rate	
			H&W	Pension	App Tr.	Vac.	Annuity	Other	LECET (*)			MISC (*)
<b>Classification</b>												
Bricklayer Tile Finisher	\$28.41		\$8.70	\$1.35	\$0.64	\$0.00	\$4.50	\$0.00	\$0.00	\$0.00	\$43.60	\$57.81
<b>Apprentice Tile Finishers</b>												
<b>Percent</b>												
1st 6 months	60.00	\$17.05	\$8.70	\$0.00	\$0.00	\$0.00	\$0.00	\$0.00	\$0.00	\$0.00	\$25.75	\$34.27
2nd 6 months	70.00	\$19.89	\$8.70	\$1.35	\$0.64	\$0.00	\$4.50	\$0.00	\$0.00	\$0.00	\$35.08	\$45.02
3rd 6 months	75.00	\$21.31	\$8.70	\$1.35	\$0.64	\$0.00	\$4.50	\$0.00	\$0.00	\$0.00	\$36.50	\$47.15
4th 6 months	80.00	\$22.73	\$8.70	\$1.35	\$0.64	\$0.00	\$4.50	\$0.00	\$0.00	\$0.00	\$37.92	\$49.28
5th 6 months	85.00	\$24.15	\$8.70	\$1.35	\$0.64	\$0.00	\$4.50	\$0.00	\$0.00	\$0.00	\$39.34	\$51.41
6th 6 months	90.00	\$25.57	\$8.70	\$1.35	\$0.64	\$0.00	\$4.50	\$0.00	\$0.00	\$0.00	\$40.76	\$53.54

## Special Calculation Note :

### Ratio :

1-4 Journeymen to 1 Apprentice  
5-10 Journeymen to 2 Apprentice  
11-16 Journeymen to 3 Apprentice

### Jurisdiction ( \* denotes special jurisdictional note ) :

ASHTABULA, CUYAHOGA, GEAUGA, LAKE,  
LORAIN, MEDINA

## Special Jurisdictional Note :

### Details :

Tile Finishers:do all the cleaning, acid washing,grouting,by any methods or means. Also unpacking of all tiles,opening of all mastic containers,mixing of all mortar,thin-set and epoxy materials,also the distribution of it. They shall handle and distribute all materials such as sand,cement,lime,tile,all types of tile panels,prefabricated tile units, plastic materials and protective covering of all tile.Clean up and removal of always used in connection of said work.



# Prevailing Wage Rate

## Skilled Crafts

Name of Union: Bricklayer Local 36 Zone 1 Tile Layer

Change # : LCN01-2021fbLoc36

Craft : Bricklayer Effective Date : 05/01/2021 Last Posted : 04/28/2021

	BHR		Fringe Benefit Payments					Irrevocable Fund		Total PWR	Overtime Rate	
			H&W	Pension	App Tr.	Vac.	Annuity	Other	LECET (*)			MISC (*)
Classification												
Bricklayer Tile Layer	\$32.32		\$8.70	\$2.43	\$0.71	\$0.00	\$6.60	\$0.00	\$0.00	\$0.00	\$50.76	\$66.92
Apprentice	Percent											
1st 30 days	60.00	\$19.39	\$0.00	\$0.00	\$0.00	\$0.00	\$0.00	\$0.00	\$0.00	\$0.00	\$19.39	\$29.09
1st 6 months	60.00	\$19.39	\$8.70	\$0.00	\$0.00	\$0.00	\$0.00	\$0.00	\$0.00	\$0.00	\$28.09	\$37.79
2nd 6 months	65.00	\$21.01	\$8.70	\$2.43	\$0.71	\$0.00	\$6.60	\$0.00	\$0.00	\$0.00	\$39.45	\$49.95
3rd 6 months	70.00	\$22.62	\$8.70	\$2.43	\$0.71	\$0.00	\$6.60	\$0.00	\$0.00	\$0.00	\$41.06	\$52.38
4th 6 months	75.00	\$24.24	\$8.70	\$2.43	\$0.71	\$0.00	\$6.60	\$0.00	\$0.00	\$0.00	\$42.68	\$54.80
5th 6 months	80.00	\$25.86	\$8.70	\$2.43	\$0.71	\$0.00	\$6.60	\$0.00	\$0.00	\$0.00	\$44.30	\$57.22
6th 6 months	85.00	\$27.47	\$8.70	\$2.43	\$0.71	\$0.00	\$6.60	\$0.00	\$0.00	\$0.00	\$45.91	\$59.65
7th 6 months	90.00	\$29.09	\$8.70	\$2.43	\$0.71	\$0.00	\$6.60	\$0.00	\$0.00	\$0.00	\$47.53	\$62.07
8th 6 months	95.00	\$30.70	\$8.70	\$2.43	\$0.71	\$0.00	\$6.60	\$0.00	\$0.00	\$0.00	\$49.14	\$64.50

**Special Calculation Note :** Classification title contains "Bricklayer" because contract originates within the Bricklayer Local.

Note that the classification description is clarified after the local union number at the top of the page.

**Ratio :**

1-4 Journeymen to 1 Apprentice  
 5-10 Journeymen to 2 Apprentice  
 11-16 Journeymen to 3 Apprentice

**Jurisdiction ( \* denotes special jurisdictional note ) :**

ASHTABULA, CUYAHOGA, GEAUGA, LAKE,  
 LORAIN, MEDINA

**Special Jurisdictional Note :**

**Details :**



# Prevailing Wage Rate Skilled Crafts

**Name of Union: Bricklayer Local 5**

**Change # : LCN01-2021fbLoc5**

**Craft : Bricklayer Effective Date : 06/01/2021 Last Posted : 04/28/2021**

	BHR		Fringe Benefit Payments					Irrevocable Fund		Total PWR	Overtime Rate	
			H&W	Pension	App Tr.	Vac.	Annuity	Other	LECET (*)			MISC (*)
Classification												
Bricklayer	\$36.62		\$8.59	\$9.45	\$0.76	\$0.00	\$0.00	\$0.00	\$0.00	\$0.00	\$55.42	\$73.73
Stone Mason	\$36.62		\$8.59	\$9.45	\$0.76	\$0.00	\$0.00	\$0.00	\$0.00	\$0.00	\$55.42	\$73.73
Pointer Caulker Cleaner	\$36.62		\$8.59	\$9.45	\$0.76	\$0.00	\$0.00	\$0.00	\$0.00	\$0.00	\$55.42	\$73.73
Marble Mason	\$36.62		\$8.59	\$9.45	\$0.76	\$0.00	\$0.00	\$0.00	\$0.00	\$0.00	\$55.42	\$73.73
Terrazzo Worker	\$36.62		\$8.59	\$9.45	\$0.76	\$0.00	\$0.00	\$0.00	\$0.00	\$0.00	\$55.42	\$73.73
Cement Mason	\$36.62		\$8.59	\$9.45	\$0.76	\$0.00	\$0.00	\$0.00	\$0.00	\$0.00	\$55.42	\$73.73
Sandblaster	\$36.87		\$8.59	\$9.45	\$0.76	\$0.00	\$0.00	\$0.00	\$0.00	\$0.00	\$55.67	\$74.10
Sewer Stack	\$37.12		\$8.59	\$9.45	\$0.76	\$0.00	\$0.00	\$0.00	\$0.00	\$0.00	\$55.92	\$74.48
Swing Scaffold	\$37.62		\$8.59	\$9.45	\$0.76	\$0.00	\$0.00	\$0.00	\$0.00	\$0.00	\$56.42	\$75.23
Masonry Maintenance Specialist	\$18.31		\$0.00	\$0.00	\$0.00	\$0.00	\$0.00	\$0.00	\$0.00	\$0.00	\$18.31	\$27.46
Apprentice	Percent											
1st 6 Months	60.00	\$21.97	\$8.59	\$0.00	\$0.00	\$0.00	\$0.00	\$0.00	\$0.00	\$0.00	\$30.56	\$41.55
2nd 6 Months	65.00	\$23.80	\$8.59	\$9.45	\$0.76	\$0.00	\$0.00	\$0.00	\$0.00	\$0.00	\$42.60	\$54.50
3rd 6 Months	70.00	\$25.63	\$8.59	\$9.45	\$0.76	\$0.00	\$0.00	\$0.00	\$0.00	\$0.00	\$44.43	\$57.25
4th 6 Months	75.00	\$27.46	\$8.59	\$9.45	\$0.76	\$0.00	\$0.00	\$0.00	\$0.00	\$0.00	\$46.26	\$60.00
5th 6 Months	80.00	\$29.30	\$8.59	\$9.45	\$0.76	\$0.00	\$0.00	\$0.00	\$0.00	\$0.00	\$48.10	\$62.74
6th 6 Months	85.00	\$31.13	\$8.59	\$9.45	\$0.76	\$0.00	\$0.00	\$0.00	\$0.00	\$0.00	\$49.93	\$65.49
7th 6 Months	90.00	\$32.96	\$8.59	\$9.45	\$0.76	\$0.00	\$0.00	\$0.00	\$0.00	\$0.00	\$51.76	\$68.24
8th 6	95.00	\$34.79	\$8.59	\$9.45	\$0.76	\$0.00	\$0.00	\$0.00	\$0.00	\$0.00	\$53.59	\$70.98

Months												
TRAINEES 1st 90 Days	45.00	\$16.48	\$0.00	\$0.00	\$0.00	\$0.00	\$0.00	\$0.00	\$0.00	\$0.00	\$16.48	\$24.72
1st Year AFTER 90 Days	45.00	\$16.48	\$8.59	\$0.00	\$0.00	\$0.00	\$0.00	\$0.00	\$0.00	\$0.00	\$25.07	\$33.31
2nd Year	50.00	\$18.31	\$8.59	\$0.00	\$0.00	\$0.00	\$0.00	\$0.00	\$0.00	\$0.00	\$26.90	\$36.05

**Special Calculation Note :**

**Ratio :**

- 1-2 Journeyman to 1 Apprentice 1 Trainee
- 3-4 Journeyman to 2 Apprentices 1 Trainee
- 5-6 Journeyman to 2 Apprentices 2 Trainees
- 6-10 Journeyman to 3 Apprentices 2 Trainees

**Jurisdiction ( \* denotes special jurisdictional note ) :**

CUYAHOGA, LORAIN, MEDINA

**Special Jurisdictional Note :** Apprentice must be hired prior to hiring Mason Trainees

**Details :**

\*Masonry Maintenance Specialist\* \* \* - in partnership with a local education organization employer may employ School to Work students providing said employee is a full time student and that no conflicts exist with any Federal or State Laws. Employer must be party to an apprentice program duly registered with the DOL and Ohio State Apprentice Compliance (OSAC). Wages for Masonry Maintenance Specialist shall be fifty-five percent (55%) of the journeyperson base rate with no fringe benefits.

# Prevailing Wage Rate

## Skilled Crafts

Name of Union: Bricklayer Local 5 Marble Mason

Change # : LCN01-2021fbLoc5

Craft : Bricklayer Effective Date : 06/01/2021 Last Posted : 04/28/2021

	BHR		Fringe Benefit Payments					Irrevocable Fund		Total PWR	Overtime Rate	
			H&W	Pension	App Tr.	Vac.	Annuity	Other	LECET (*)			MISC (*)
<b>Classification</b>												
Bricklayer Horizontal Marble Mason	\$25.58		\$8.59	\$9.45	\$0.64	\$0.00	\$0.00	\$0.00	\$0.00	\$0.00	\$44.26	\$57.05
Masonry Maintenance Specialist	\$12.79		\$0.00	\$0.00	\$0.00	\$0.00	\$0.00	\$0.00	\$0.00	\$0.00	\$12.79	\$19.18
<b>Apprentice</b>	<b>Percent</b>											
1st 6 Months	60.00	\$15.35	\$8.59	\$0.00	\$0.00	\$0.00	\$0.00	\$0.00	\$0.00	\$0.00	\$23.94	\$31.61
2nd 6 Months	65.00	\$16.63	\$8.59	\$1.60	\$0.64	\$0.00	\$0.00	\$0.00	\$0.00	\$0.00	\$27.46	\$35.77
3rd 6 Months	70.00	\$17.91	\$8.59	\$9.45	\$0.64	\$0.00	\$0.00	\$0.00	\$0.00	\$0.00	\$36.59	\$45.54
4th 6 Months	75.00	\$19.18	\$8.59	\$9.45	\$0.64	\$0.00	\$0.00	\$0.00	\$0.00	\$0.00	\$37.86	\$47.46
5th 6 Months	80.00	\$20.46	\$8.59	\$9.45	\$0.64	\$0.00	\$0.00	\$0.00	\$0.00	\$0.00	\$39.14	\$49.38
6th 6 Months	85.00	\$21.74	\$8.59	\$9.45	\$0.64	\$0.00	\$0.00	\$0.00	\$0.00	\$0.00	\$40.42	\$51.29
<b>MASON TRAINEES</b>												
1st 90 Days	45.00	\$11.51	\$0.00	\$0.00	\$0.00	\$0.00	\$0.00	\$0.00	\$0.00	\$0.00	\$11.51	\$17.27
1st year after 90 Days	45.00	\$11.51	\$8.59	\$0.00	\$0.00	\$0.00	\$0.00	\$0.00	\$0.00	\$0.00	\$20.10	\$25.86
2nd Year	50.00	\$12.79	\$8.59	\$0.00	\$0.00	\$0.00	\$0.00	\$0.00	\$0.00	\$0.00	\$21.38	\$27.77

**Special Calculation Note :** No special calculations for this skilled craft wage rate are required at this time.

Classification title contains "Bricklayer" because contract originates within the Bricklayer Local.

**Ratio :**

1-2 Journeyman to 1 Apprentice  
3-4 Journeyman to 2 Apprentices  
5-6 Journeyman to 2 Apprentices  
6-10 Journeyman to 3 Apprentices

1 Apprentice permits 1 Mason Trainee  
2 Apprentice permits 1 Mason Trainee  
3 Apprentice permits 2 Mason Trainee  
4 Apprentice permits 2 Mason Trainee

**Special Jurisdictional Note :****Details :**

In the mutual interest of both Employer and Union and to promote the masonry industry, it is agreed that the Employer may work with the Union and the Local Educational Partners in the jurisdiction of this agreement to employ School to work students provided that no conflicts exist with any Federal or State Laws. Employer must be party to a bonified Apprenticeship and Training program registered with the State of Ohio (OSAC). It is further agreed by both parties that the wages for the Masonry Maintenance Specialist shall be forty-five percent (45%) of the journeyman rate with no fringe benefits or as specified by the Local Educational Partner in the jurisdiction of the agreement.

**Jurisdiction ( \* denotes special jurisdictional note ) :**

ASHTABULA, CUYAHOGA, GEAUGA, LAKE,  
LORAIN, MEDINA, PORTAGE, SUMMIT

# Prevailing Wage Rate Skilled Crafts

Name of Union: Bricklayer Local 5 Tile & Marble Finisher

Change # : LCN01-2021fbLoc5

Craft : Bricklayer Effective Date : 05/01/2021 Last Posted : 04/28/2021

	BHR		Fringe Benefit Payments					Irrevocable Fund		Total PWR	Overtime Rate	
			H&W	Pension	App Tr.	Vac.	Annuity	Other	LECET (*)			MISC (*)
<b>Classification</b>												
Bricklayer Tile Marble Finisher	\$29.60		\$8.59	\$4.77	\$0.64	\$0.00	\$0.00	\$0.00	\$0.00	\$0.00	\$43.60	\$58.40
<b>Apprentice Tile Marble Finishers</b>												
<b>Percent</b>												
1st 6 months	60.00	\$17.76	\$8.59	\$0.00	\$0.00	\$0.00	\$0.00	\$0.00	\$0.00	\$0.00	\$26.35	\$35.23
2nd 6 months	70.00	\$20.72	\$8.59	\$4.77	\$0.64	\$0.00	\$0.00	\$0.00	\$0.00	\$0.00	\$34.72	\$45.08
3rd 6 months	75.00	\$22.20	\$8.59	\$4.77	\$0.64	\$0.00	\$0.00	\$0.00	\$0.00	\$0.00	\$36.20	\$47.30
4th 6 months	80.00	\$23.68	\$8.59	\$4.77	\$0.64	\$0.00	\$0.00	\$0.00	\$0.00	\$0.00	\$37.68	\$49.52
5th 6 months	85.00	\$25.16	\$8.59	\$4.77	\$0.64	\$0.00	\$0.00	\$0.00	\$0.00	\$0.00	\$39.16	\$51.74
6th 6 months	90.00	\$26.64	\$8.59	\$4.77	\$0.64	\$0.00	\$0.00	\$0.00	\$0.00	\$0.00	\$40.64	\$53.96

**Special Calculation Note :** Classification title contains "Bricklayer" because contract originates within the Bricklayer Local.

Note that the classification description is clarified after the local union number at the top of the page.

## Ratio :

1-2 Journeymen to 1 Apprentice  
3- 4 Journeymen to 2 Apprentice  
5-6 Journeymen to 3 Apprentice  
7-8 Journeymen to 4 Apprentice

## Jurisdiction ( \* denotes special jurisdictional note ) :

ASHTABULA, CUYAHOGA, GEAUGA, LAKE,  
LORAIN, MEDINA, PORTAGE, SUMMIT

## Special Jurisdictional Note :

## Details :

Tile Finishers:do all the cleaning, acid washing,grouting,by any methods or means. Also unpacking of all tiles,opening of all mastic containers,mixing of all mortar,thin-set and epoxy materials,also the distribution of it.

They shall handle and distribute all materials such as sand, cement, lime, tile, all types of tile panels, prefabricated tile units, plastic materials and protective covering of all tile. Clean up and removal of always used in connection of said work.

Terrazzo Finishers: Assisting in grinding, and handling of material whether by hand or wheel barrow, or power buggies, including sand Portland cement, resinous cement and admixtures, aggregates of marble, stone or other compositions, bonding adhesives, sealers, waxes, and coatings used for Terrazzo Mosaic work, preparing, mixing by hand or machine, and distributing (spreading) all kinds of underbed or underlayment necessary and all scratch coat used for terrazzo and mosaic work. Also the rubbing, grinding, cleaning, sealing and polishing same either by hand or machine. will assist in the installation of the sand bed, tar paper, wire lath, divider strips, and rolling procedures and acid etching of all concrete floors that require it before installation. Shall handle all materials and assist in the installation of all types of terrazzo floors whether conventional or thin-set variety.

Marble Finishers: Loading and unloading handling and distributing of marble materials including the mixing of all materials used for the installation of marble, such as cement underbeds for the floors, thin-set or epoxies including but not limited to plastic materials. Clean up and removal of all waster material of said work. Cleaning and grouting of all marble and slate, and all polishing of marble and slate floors.

# Prevailing Wage Rate Skilled Crafts

Name of Union: Bricklayer Local 5 Terrazzo Finisher

Change # : LCN01-2021fbLoc5

Craft : Bricklayer Effective Date : 05/01/2021 Last Posted : 04/28/2021

	BHR		Fringe Benefit Payments						Irrevocable Fund		Total PWR	Overtime Rate
			H&W	Pension	App Tr.	Vac.	Annuity	Other	LECET (*)	MISC (*)		
<b>Classification</b>												
Bricklayer Terrazzo Finisher	\$29.22		\$8.59	\$5.15	\$0.64	\$0.00	\$0.00	\$0.00	\$0.00	\$0.00	\$43.60	\$58.21
<b>Apprentice Terrazzo Finishers</b>												
<b>Percent</b>												
1st 6 months	60.00	\$17.53	\$8.59	\$0.00	\$0.00	\$0.00	\$0.00	\$0.00	\$0.00	\$0.00	\$26.12	\$34.89
2nd 6 months	70.00	\$20.45	\$8.59	\$5.15	\$0.64	\$0.00	\$0.00	\$0.00	\$0.00	\$0.00	\$34.83	\$45.06
3rd 6 months	75.00	\$21.91	\$8.59	\$5.15	\$0.64	\$0.00	\$0.00	\$0.00	\$0.00	\$0.00	\$36.30	\$47.25
4th 6 months	80.00	\$23.38	\$8.59	\$5.15	\$0.64	\$0.00	\$0.00	\$0.00	\$0.00	\$0.00	\$37.76	\$49.44
5th 6 months	85.00	\$24.84	\$8.59	\$5.15	\$0.64	\$0.00	\$0.00	\$0.00	\$0.00	\$0.00	\$39.22	\$51.64
6th 6 months	90.00	\$26.30	\$8.59	\$5.15	\$0.64	\$0.00	\$0.00	\$0.00	\$0.00	\$0.00	\$40.68	\$53.83

**Special Calculation Note :** Classification title contains "Bricklayer" because contract originates within the Bricklayer Local.

Note that the classification description is clarified after the local union number at the top of the page.

## Ratio :

1-2 Journeymen to 1 Apprentice  
3- 4 Journeymen to 2 Apprentices  
5- 6 Journeymen to 3 Apprentices  
7- 8 Journeymen to 4 Apprentices

## Jurisdiction ( \* denotes special jurisdictional note ) :

ASHTABULA, CUYAHOGA, GEAUGA, LAKE,  
LORAIN, MEDINA, PORTAGE, SUMMIT

## Special Jurisdictional Note :

## Details :

Tile Finishers:do all the cleaning, acid washing,grouting,by any methods or means. Also unpacking of all tiles,opening of all mastic containers,mixing of all mortar,thin-set and epoxy materials,also the distribution of it. They shall handle and distribute all materials such as sand,cement,lime,tile,all types of tile panels,prefabricated

tile units, plastic materials and protective covering of all tile. Clean up and removal of always used in connection of said work.

**Terrazzo Finishers:**Assisting in grinding, and handling of material whether by hand or wheel barrow, or power buggies, including sand Portland cement, resinous cement and admixtures, aggregates of marble, stone or other compositions, bonding adhesives, sealers, waxes, and coatings used for Terrazzo Mosaic work, preparing, mixing by hand or machine, and distributing (spreading) all kinds of underbed or underlayment necessary and all scratch coat used for terrazzo and mosaic work. Also the rubbing, grinding, cleaning, sealing and polishing same either by hand or machine. will assist in the installation of the sand bed, tar paper, wire lath, divider strips, and rolling procedures and acid etching of all concrete floors that require it before installation. Shall handle all materials and assist in the installation of all types of terrazzo floors whether conventional or thin-set variety.

**Marble Finishers:**Loading and unloading handling and distributing of marble materials including the mixing of all materials used for the installation of marble, such as cement underbeds for the floors, thin-set or epoxies including but not limited to plastic materials. Clean up and removal of all waster material of said work. Cleaning and grouting of all marble and slate, and all polishing of marble and slate floors.

# Prevailing Wage Rate Skilled Crafts

Name of Union: Carpenter Commercial NE Zone 1B

Change # : LCN01-2020fbLocNEZone1B

Craft : Carpenter Effective Date : 05/28/2020 Last Posted : 05/28/2020

	BHR		Fringe Benefit Payments					Irrevocable Fund		Total PWR	Overtime Rate	
			H&W	Pension	App Tr.	Vac.	Annuity	Other	LECET (*)			MISC (*)
Classification												
Carpenter	\$29.15		\$7.75	\$9.63	\$0.50	\$0.00	\$1.26	\$0.00	\$0.00	\$0.00	\$48.29	\$62.86
Apprentice	Percent											
1st 3 Months	60.00	\$17.49	\$0.00	\$0.00	\$0.00	\$0.00	\$0.00	\$0.00	\$0.00	\$0.00	\$17.49	\$26.23
2nd 3 Months	60.00	\$17.49	\$7.75	\$0.00	\$0.50	\$0.00	\$0.00	\$0.00	\$0.00	\$0.00	\$25.74	\$34.49
2nd 6 Months	60.00	\$17.49	\$7.75	\$0.00	\$0.50	\$0.00	\$0.00	\$0.00	\$0.00	\$0.00	\$25.74	\$34.49
3rd 6 Months	60.00	\$17.49	\$7.75	\$0.00	\$0.50	\$0.00	\$0.00	\$0.00	\$0.00	\$0.00	\$25.74	\$34.49
4th 6 Months	60.00	\$17.49	\$7.75	\$0.00	\$0.50	\$0.00	\$0.00	\$0.00	\$0.00	\$0.00	\$25.74	\$34.49
5th 6 Months	70.00	\$20.40	\$7.75	\$6.74	\$0.50	\$0.00	\$0.88	\$0.00	\$0.00	\$0.00	\$36.28	\$46.48
6th 6 Months	75.00	\$21.86	\$7.75	\$7.22	\$0.50	\$0.00	\$0.95	\$0.00	\$0.00	\$0.00	\$38.28	\$49.21
7th 6 Months	80.00	\$23.32	\$7.75	\$7.70	\$0.50	\$0.00	\$1.01	\$0.00	\$0.00	\$0.00	\$40.28	\$51.94
8th 6 Months	85.00	\$24.78	\$7.75	\$8.19	\$0.50	\$0.00	\$1.07	\$0.00	\$0.00	\$0.00	\$42.29	\$54.68

**Special Calculation Note :**

**Ratio :**

2 Journeymen to 1 Apprentice

**Jurisdiction ( \* denotes special jurisdictional note ):**

LORAIN

**Special Jurisdictional Note :**

**Details :**

# Prevailing Wage Rate Skilled Crafts

Name of Union: Carpenter Floorlayer NE Zone 1B

Change # : LCN01-2020fbLocNEZone1B

Craft : Carpenter Effective Date : 05/28/2020 Last Posted : 05/28/2020

	BHR		Fringe Benefit Payments					Irrevocable Fund		Total PWR	Overtime Rate	
			H&W	Pension	App Tr.	Vac.	Annuity	Other	LECET (*)			MISC (*)
Classification												
Carpenter Floorlayer	\$29.15		\$7.75	\$9.63	\$0.52	\$0.00	\$1.26	\$0.00	\$0.00	\$0.00	\$48.31	\$62.89
Apprentice	Percent											
1st 3 Months	60.00	\$17.49	\$0.00	\$0.00	\$0.00	\$0.00	\$0.00	\$0.00	\$0.00	\$0.00	\$17.49	\$26.23
2nd 3 Months	60.00	\$17.49	\$7.75	\$0.00	\$0.52	\$0.00	\$0.00	\$0.00	\$0.00	\$0.00	\$25.76	\$34.51
2nd 6 Months	60.00	\$17.49	\$7.75	\$0.00	\$0.52	\$0.00	\$0.00	\$0.00	\$0.00	\$0.00	\$25.76	\$34.51
3rd 6 Months	60.00	\$17.49	\$7.75	\$0.00	\$0.52	\$0.00	\$0.00	\$0.00	\$0.00	\$0.00	\$25.76	\$34.51
4th 6 Months	60.00	\$17.49	\$7.75	\$0.00	\$0.52	\$0.00	\$0.00	\$0.00	\$0.00	\$0.00	\$25.76	\$34.51
5th 6 Months	70.00	\$20.40	\$7.75	\$6.74	\$0.52	\$0.00	\$0.88	\$0.00	\$0.00	\$0.00	\$36.30	\$46.50
6th 6 Months	75.00	\$21.86	\$7.75	\$7.22	\$0.52	\$0.00	\$0.95	\$0.00	\$0.00	\$0.00	\$38.30	\$49.23
7th 6 Months	80.00	\$23.32	\$7.75	\$7.70	\$0.52	\$0.00	\$1.01	\$0.00	\$0.00	\$0.00	\$40.30	\$51.96
8th 6 Months	85.00	\$24.78	\$7.75	\$8.19	\$0.52	\$0.00	\$1.07	\$0.00	\$0.00	\$0.00	\$42.31	\$54.70

**Special Calculation Note :**

**Ratio :**

2 Journeymen to 1 Apprentice

**Jurisdiction ( \* denotes special jurisdictional note ):**

LORAIN

**Special Jurisdictional Note :**

**Details :**

# Prevailing Wage Rate Skilled Crafts

Name of Union: Carpenter Insulation NE Zone 1B

Change # : LCN01-2020fbLocNEZone1B

Craft : Carpenter Effective Date : 05/28/2020 Last Posted : 05/28/2020

	BHR		Fringe Benefit Payments					Irrevocable Fund		Total PWR	Overtime Rate	
			H&W	Pension	App Tr.	Vac.	Annuity	Other	LECET (*)			MISC (*)
Classification												
Carpenter Insulation	\$23.32		\$7.75	\$9.63	\$0.50	\$0.00	\$1.26	\$0.00	\$0.00	\$0.00	\$42.46	\$54.12
Apprentice	Percent											
1st 3 Months	50.00	\$11.66	\$0.00	\$0.00	\$0.00	\$0.00	\$0.00	\$0.00	\$0.00	\$0.00	\$11.66	\$17.49
2nd 3 Months	50.00	\$11.66	\$7.75	\$0.00	\$0.50	\$0.00	\$0.00	\$0.00	\$0.00	\$0.00	\$19.91	\$25.74
2nd 6 Months	50.00	\$11.66	\$7.75	\$0.00	\$0.50	\$0.00	\$0.00	\$0.00	\$0.00	\$0.00	\$19.91	\$25.74
3rd 6 Months	55.00	\$12.83	\$7.75	\$0.00	\$0.50	\$0.00	\$0.00	\$0.00	\$0.00	\$0.00	\$21.08	\$27.49
4th 6 Months	60.00	\$13.99	\$7.75	\$0.00	\$0.50	\$0.00	\$0.00	\$0.00	\$0.00	\$0.00	\$22.24	\$29.24
5th 6 Months	70.00	\$16.32	\$7.75	\$6.74	\$0.50	\$0.00	\$0.88	\$0.00	\$0.00	\$0.00	\$32.19	\$40.36
6th 6 Months	75.00	\$17.49	\$7.75	\$7.22	\$0.50	\$0.00	\$0.95	\$0.00	\$0.00	\$0.00	\$33.91	\$42.66
7th 6 Months	80.00	\$18.66	\$7.75	\$7.70	\$0.50	\$0.00	\$1.01	\$0.00	\$0.00	\$0.00	\$35.62	\$44.94
8th 6 Months	85.00	\$19.82	\$7.75	\$8.19	\$0.50	\$0.00	\$1.07	\$0.00	\$0.00	\$0.00	\$37.33	\$47.24

**Special Calculation Note :** No special calculations for this skilled craft wage rate are required at this time.

**Ratio :**  
2 Journeymen to 1 Apprentice

**Jurisdiction ( \* denotes special jurisdictional note ):**  
LORAIN

**Special Jurisdictional Note :**

**Details :**

# Prevailing Wage Rate Skilled Crafts

Name of Union: Carpenter Millwright NE Zone M1

Change # : LCN01-2020fbLocNEZoneM1

Craft : Carpenter Effective Date : 05/28/2020 Last Posted : 05/28/2020

	BHR		Fringe Benefit Payments					Irrevocable Fund		Total PWR	Overtime Rate	
			H&W	Pension	App Tr.	Vac.	Annuity	Other	LECET (*)			MISC (*)
Classification												
Carpenter Millwright	\$30.63		\$7.75	\$10.13	\$0.50	\$0.00	\$4.44	\$0.05	\$0.00	\$0.00	\$53.50	\$68.81
Certified Welder	\$31.63		\$7.75	\$10.13	\$0.50	\$0.00	\$4.44	\$0.05	\$0.00	\$0.00	\$54.50	\$70.31
Layout man on Monorail	\$32.38		\$7.75	\$10.13	\$0.50	\$0.00	\$4.44	\$0.05	\$0.00	\$0.00	\$55.25	\$71.44
Apprentice	Percent											
1st 6 months	60.00	\$18.38	\$7.75	\$10.13	\$0.50	\$0.00	\$4.44	\$0.05	\$0.00	\$0.00	\$41.25	\$50.44
2nd 6 months	60.00	\$18.38	\$7.75	\$10.13	\$0.50	\$0.00	\$4.44	\$0.05	\$0.00	\$0.00	\$41.25	\$50.44
3rd 6 months	62.00	\$18.99	\$7.75	\$10.13	\$0.50	\$0.00	\$4.44	\$0.05	\$0.00	\$0.00	\$41.86	\$51.36
4th 6 months	65.50	\$20.06	\$7.75	\$10.13	\$0.50	\$0.00	\$4.44	\$0.05	\$0.00	\$0.00	\$42.93	\$52.96
5th 6 months	69.00	\$21.13	\$7.75	\$10.13	\$0.50	\$0.00	\$4.44	\$0.05	\$0.00	\$0.00	\$44.00	\$54.57
6th 6 months	72.50	\$22.21	\$7.75	\$10.13	\$0.50	\$0.00	\$4.44	\$0.05	\$0.00	\$0.00	\$45.08	\$56.18
7th 6 months	76.00	\$23.28	\$7.75	\$10.13	\$0.50	\$0.00	\$4.44	\$0.05	\$0.00	\$0.00	\$46.15	\$57.79
8th 6 months	80.00	\$24.50	\$7.75	\$10.13	\$0.50	\$0.00	\$4.44	\$0.05	\$0.00	\$0.00	\$47.37	\$59.63

**Special Calculation Note :** Other \$0.05 is for UBC Millwright Promotional Fund

**Ratio :**

2 Journeymen to 1 Apprentice

**Jurisdiction ( \* denotes special jurisdictional note ):**

ASHLAND, ASHTABULA, CUYAHOGA, ERIE, GEAUGA, HURON, LAKE, LORAIN, MEDINA, PORTAGE, RICHLAND, SUMMIT

**Special Jurisdictional Note :**

## **Details :**

The term "Millwright and Machine Erectors" jurisdiction shall mean the unloading, hoisting, rigging, skidding, moving, dismantling, aligning, erecting, assembling, repairing, maintenance and adjusting of all structures, processing areas either under cover, under ground or elsewhere, required to process material, handle, manufacture or service, be it powered or receiving power manually, by steam, gas, electricity, gasoline, diesel, nuclear, solar, water, air or chemically, and in industries such as and including, which are identified for the purpose of description, but not limited to, the following: woodworking plants; canning industries; steel mills; coffee roasting plants; paper and pulp; cellophane; stone crushing; gravel and sand washing and handling; refineries; grain storage and handling; asphalt plants; sewage disposal; water plants; laundries; bakeries; mixing plants; can, bottle and bag packing plants; textile mills; paint mills; breweries; milk processing plants; power plants; aluminum processing or manufacturing plants; and amusement and entertainment fields. The installation of mechanical equipment in atomic energy plants; installation of reactors in power plants; installation of control rods and equipment in reactors; and installation of mechanical equipment in rocket missile bases, launchers, launching gantry, floating bases, hydraulic escape doors and any and all component parts thereto, either assembled, semi-assembled or disassembled. The installation of, but not limited to, the following: setting-up of all engines, motors, generators, air compressors, fans, pumps, scales, hoppers, conveyors of all types, sizes and their supports; escalators; man lifts; moving sidewalks; hoists; dumb waiters; all types of feeding machinery; amusement devices; mechanical pin setters and spotters in bowling alleys; refrigeration equipment; and the installation of all types of equipment necessary and required to process material either in the manufacturing or servicing. The handling and installation of pulleys, gears, sheaves, fly wheels, air and vacuum drives, worm drives and gear drives directly or indirectly coupled to motors, belts, chains, screws, legs, boots, guards, booth tanks, all bin valves, turn heads and indicators, shafting, bearings, cable sprockets, cutting all key seats in new and old work, troughs, chippers, filters, calendars, rolls, winders, rewinders, slitters, cutters, wrapping machines, blowers, forging machines, rams, hydraulic or otherwise, planing, extruder, ball, dust collectors, equipment in meat packing plants, splicing of ropes and cables. The laying-out, fabrication and installation of protection equipment including machinery guards, making and setting of templates for machinery, fabrication of bolts, nuts, pans, drilling of holes for any equipment which the Millwrights install regardless of materials; all welding and burning regardless of type, fabrication of all lines, hose or tubing used in lubricating machinery installed by Millwrights; grinding, cleaning, servicing and any machine work necessary for any part of any equipment installed by the Millwrights; and the break-in and trial run of any equipment or machinery installed by the Millwrights. It is agreed the Millwrights shall use the layout tools and optic equipment necessary to perform their work.

# Prevailing Wage Rate Skilled Crafts

Name of Union: Carpenter NE District Industrial Dock & Door

Change # : LCN01-2014fbCarpNEStatewide

Craft : Carpenter Effective Date : 03/05/2014 Last Posted : 03/05/2014

	BHR		Fringe Benefit Payments					Irrevocable Fund		Total PWR	Overtime Rate	
			H&W	Pension	App Tr.	Vac.	Annuity	Other	LECET (*)			MISC (*)
Classification												
Carpenter	\$19.70		\$5.05	\$1.00	\$0.15	\$0.00	\$0.00	\$0.00	\$0.00	\$0.00	\$25.90	\$35.75
Trainee	Percent											
1st Year	60.00	\$11.82	\$5.05	\$1.00	\$0.15	\$0.00	\$0.00	\$0.00	\$0.00	\$0.00	\$18.02	\$23.93
2nd Year	80.20	\$15.80	\$5.05	\$1.00	\$0.15	\$0.00	\$0.00	\$0.00	\$0.00	\$0.00	\$22.00	\$29.90

**Special Calculation Note :** No special calculations for this skilled craft wage rate are required at this time.

**Ratio :**

1 Journeymen to 1 Trainee

**Jurisdiction ( \* denotes special jurisdictional note ) :**

ADAMS, ALLEN, ASHLAND, ASHTABULA, ATHENS, AUGLAIZE, BELMONT, BROWN, BUTLER, CARROLL, CHAMPAIGN, CLARK, CLERMONT, CLINTON, COLUMBIANA, COSHOCTON, CRAWFORD, CUYAHOGA, DARKE, DEFIANCE, DELAWARE, ERIE, FAIRFIELD, FAYETTE, FRANKLIN, FULTON, GALLIA, GEAUGA, GREENE, GUERNSEY, HAMILTON, HANCOCK, HARDIN, HARRISON, HENRY, HIGHLAND, HOCKING, HOLMES, HURON, JACKSON, JEFFERSON, KNOX, LAKE, LAWRENCE, LICKING, LOGAN, LORAIN, LUCAS, MADISON, MAHONING, MARION, MEDINA, MEIGS, MERCER, MIAMI, MONROE, MONTGOMERY, MORGAN, MORROW, MUSKINGUM, NOBLE, OTTAWA, PAULDING, PERRY, PICKAWAY, PIKE, PORTAGE, PREBLE, PUTNAM, RICHLAND, ROSS, SANDUSKY, SCIOTO, SENECA, SHELBY, STARK, SUMMIT, TRUMBULL, TUSCARAWAS, UNION, VAN WERT, VINTON, WARREN, WASHINGTON, WAYNE, WILLIAMS, WOOD, WYANDOT

**Special Jurisdictional Note :** Industrial Dock and Door is the installation of overhead doors, roll up doors and dock leveling equipment

# Prevailing Wage Rate Skilled Crafts

Name of Union: Carpenter Pile Driver NE Zone P1

Change # : LCN01-2020fbLocNEZoneP1

Craft : Carpenter Effective Date : 05/28/2020 Last Posted : 05/28/2020

	BHR		Fringe Benefit Payments					Irrevocable Fund		Total PWR	Overtime Rate	
			H&W	Pension	App Tr.	Vac.	Annuity	Other	LECET (*)			MISC (*)
Classification												
Carpenter Pile Driver	\$30.89		\$7.75	\$10.13	\$0.50	\$0.00	\$4.23	\$0.00	\$0.00	\$0.00	\$53.50	\$68.95
Diver	\$46.34		\$7.75	\$10.13	\$0.50	\$0.00	\$4.23	\$0.00	\$0.00	\$0.00	\$68.95	\$92.12
Certified Welder	\$31.94		\$7.75	\$10.13	\$0.50	\$0.00	\$4.23	\$0.00	\$0.00	\$0.00	\$54.55	\$70.52
Apprentice	Percent											
1st 6 months	60.00	\$18.53	\$7.75	\$10.13	\$0.50	\$0.00	\$4.23	\$0.00	\$0.00	\$0.00	\$41.14	\$50.41
2nd 6 months	60.00	\$18.53	\$7.75	\$10.13	\$0.50	\$0.00	\$4.23	\$0.00	\$0.00	\$0.00	\$41.14	\$50.41
3rd 6 months	62.00	\$19.15	\$7.75	\$10.13	\$0.50	\$0.00	\$4.23	\$0.00	\$0.00	\$0.00	\$41.76	\$51.34
4th 6 months	65.50	\$20.23	\$7.75	\$10.13	\$0.50	\$0.00	\$4.23	\$0.00	\$0.00	\$0.00	\$42.84	\$52.96
5th 6 months	69.00	\$21.31	\$7.75	\$10.13	\$0.50	\$0.00	\$4.23	\$0.00	\$0.00	\$0.00	\$43.92	\$54.58
6th 6 months	72.50	\$22.40	\$7.75	\$10.13	\$0.50	\$0.00	\$4.23	\$0.00	\$0.00	\$0.00	\$45.01	\$56.20
7th 6 months	76.00	\$23.48	\$7.75	\$10.13	\$0.50	\$0.00	\$4.23	\$0.00	\$0.00	\$0.00	\$46.09	\$57.82
8th 6 months	80.00	\$24.71	\$7.75	\$10.13	\$0.50	\$0.00	\$4.23	\$0.00	\$0.00	\$0.00	\$47.32	\$59.68

**Special Calculation Note :** No special calculations for this skilled craft wage rate are required at this time.

**Ratio :**

2 Journeymen to 1 Apprentice

**Jurisdiction ( \* denotes special jurisdictional note ):**

ASHLAND, ASHTABULA, CUYAHOGA, ERIE, GEAUGA, HURON, LAKE, LORAIN, MEDINA, PORTAGE, RICHLAND, SUMMIT

**Special Jurisdictional Note :**

**Details :**

Pile Drivers duties shall include but not limited to: Pile driving, milling, fashioning, joining assembling, erecting,

fastening, or dismantling of all material of wood, plastic, metal, fiber, cork and composition and all other substitute materials: pile driving, cutting, fitting and placing of lagging, and the handling, cleaning, erecting, installing and dismantling of machinery, equipment and erecting pre-engineered metal buildings. Pile Drivers work but not limited to: unloading, assembling, erection, repairs, operation, signaling, dismantling and reloading all equipment that is used for pile driving including pile butts is defined as sheeting or scrap piling. Underwater work that may be required in connection with the installation of piling. The driver and his tender work as a team and shall arrive at their own financial arrangements with the contractor. Any configuration of wood, steel, concrete or composite that is jettied, driven or vibrated onto the ground by conventional pile driving equipment for the purpose of supporting a future load that may be permanent or temporary. The construction of all wharves and docks, including the fabrication and installation of floating docks. Driving bracing, plumbing, cutting off and capping of all piling whether wood, metal, pipe piling or composite, loading, unloading, erecting, framing, dismantling, moving and handling of pile driving equipment piling used in the construction and repair of all wharves, docks, piers, trestles, caissons, cofferdams and erection of all sea walls and breakwaters. All underwater and marine work on bulkheads, wharves, docks, shipyards, caissons, piers, bridges, pipeline, work, viaducts, marine cable and trestles, as well as salvage and reclamation work where divers are employed. Rate shall include carpenters, acoustic and ceiling installers, drywall installers, pile drivers and floorlayers.

# Prevailing Wage Rate Skilled Crafts

Name of Union: Cement Mason Bricklayer Local 97 HevHwy A

Change # : LCN01-2020fbHvyHwy

Craft : Bricklayer Effective Date : 06/01/2020 Last Posted : 05/21/2020

	BHR		Fringe Benefit Payments					Irrevocable Fund		Total PWR	Overtime Rate	
			H&W	Pension	App Tr.	Vac.	Annuity	Other	LECET (*)			MISC (*)
<b>Classification</b>												
Cement Mason Bricklayer Sewer Water Works A	\$29.96		\$9.50	\$6.77	\$0.47	\$0.00	\$0.00	\$0.00	\$0.00	\$0.00	\$46.70	\$61.68
<b>Apprentice</b>	<b>Percent</b>											
1st year	50.00	\$14.98	\$9.50	\$6.77	\$0.47	\$0.00	\$0.00	\$0.00	\$0.00	\$0.00	\$31.72	\$39.21
2nd year	70.00	\$20.97	\$9.50	\$6.77	\$0.47	\$0.00	\$0.00	\$0.00	\$0.00	\$0.00	\$37.71	\$48.20
3rd year	90.00	\$26.96	\$9.50	\$6.77	\$0.47	\$0.00	\$0.00	\$0.00	\$0.00	\$0.00	\$43.70	\$57.19

**Special Calculation Note : NOT FOR BUILDING CONSTRUCTION.**

**Ratio :**

- 3 Journeymen to 1 Apprentice
- 6 Journeymen to 2 Apprentice
- 9 Journeymen to 3 Apprentice
- 12 Journeymen to 4 Apprentice
- 15 Journeymen to 5 Apprentice

**Jurisdiction ( \* denotes special jurisdictional note ):**

- ADAMS, ALLEN, ASHLAND, ASHTABULA, ATHENS, AUGLAIZE, BELMONT, BROWN, BUTLER, CARROLL, CHAMPAIGN, CLARK, CLERMONT, CLINTON, COLUMBIANA, COSHOCTON, CRAWFORD, CUYAHOGA, DARKE, DEFIANCE, DELAWARE, ERIE, FAIRFIELD, FAYETTE, FRANKLIN, FULTON, GALLIA, GEAUGA, GREENE, GUERNSEY, HAMILTON, HANCOCK, HARDIN, HARRISON, HENRY, HIGHLAND, HOCKING, HOLMES, HURON, JACKSON, JEFFERSON, KNOX, LAKE, LAWRENCE, LICKING, LOGAN, LORAIN, LUCAS, MADISON, MAHONING, MARION, MEDINA, MEIGS, MERCER, MIAMI, MONROE, MONTGOMERY, MORGAN, MORROW, MUSKINGUM, NOBLE, OTTAWA, PAULDING, PERRY, PICKAWAY, PIKE, PORTAGE, PREBLE, PUTNAM, RICHLAND, ROSS, SANDUSKY, SCIOTO, SENECA, SHELBY, STARK, SUMMIT, TRUMBULL, TUSCARAWAS, UNION, VAN WERT, VINTON, WARREN, WASHINGTON, WAYNE

## **Special Jurisdictional Note :**

### **Details :**

(A) Highway Construction, Sewer, Waterworks And Utility Construction, Industrial & Building Site Heavy Construction, Airport Construction Or Railroad Construction Work.

(B) Power Plant, Tunnels, Amusement Park, Athletic Stadium Site Work ,Pollution Control,Sewer Plant, Waste Plant, & Water Treatment Facilities, Construction.

# Prevailing Wage Rate Skilled Crafts

**Name of Union: Cement Mason Bricklayer Local 97 HevHwy B**

**Change # : LCN01-2020fbHvyHwy**

**Craft : Bricklayer Effective Date : 06/01/2020 Last Posted : 05/21/2020**

	BHR		Fringe Benefit Payments					Irrevocable Fund		Total PWR	Overtime Rate	
			H&W	Pension	App Tr.	Vac.	Annuity	Other	LECET (*)			MISC (*)
<b>Classification</b>												
Cement Mason Bricklayer Power Plants Tunnels Amusement Parks B	\$30.95		\$9.50	\$6.77	\$0.48	\$0.00	\$0.00	\$0.00	\$0.00	\$0.00	\$47.70	\$63.17
<b>Apprentice</b>	<b>Percent</b>											
1st year	50.00	\$15.48	\$9.50	\$6.77	\$0.48	\$0.00	\$0.00	\$0.00	\$0.00	\$0.00	\$32.23	\$39.96
2nd year	70.00	\$21.66	\$9.50	\$6.77	\$0.48	\$0.00	\$0.00	\$0.00	\$0.00	\$0.00	\$38.42	\$49.25
3rd year	90.00	\$27.85	\$9.50	\$6.77	\$0.48	\$0.00	\$0.00	\$0.00	\$0.00	\$0.00	\$44.60	\$58.53

**Special Calculation Note : NOT FOR BUILDING CONSTRUCTION.**

**Ratio :**

- 3 Journeymen to 1 Apprentice
- 6 Journeymen to 2 Apprentice
- 9 Journeymen to 2 Apprentice
- 12 Journeymen to 4 Apprentice
- 15 Journeymen to 5 Apprentice

**Jurisdiction ( \* denotes special jurisdictional note ):**

- ADAMS, ALLEN, ASHLAND, ASHTABULA, ATHENS, AUGLAIZE, BELMONT, BROWN, BUTLER, CARROLL, CHAMPAIGN, CLARK, CLERMONT, CLINTON, COLUMBIANA, COSHOCTON, CRAWFORD, CUYAHOGA, DARKE, DEFIANCE, DELAWARE, ERIE, FAIRFIELD, FAYETTE, FRANKLIN, FULTON, GALLIA, GEAUGA, GREENE, GUERNSEY, HAMILTON, HANCOCK, HARDIN, HARRISON, HENRY, HIGHLAND, HOCKING, HOLMES, HURON, JACKSON, JEFFERSON, KNOX, LAKE, LAWRENCE, LICKING, LOGAN, LORAIN, LUCAS, MADISON, MAHONING, MARION, MEDINA, MEIGS, MERCER, MIAMI, MONROE, MONTGOMERY, MORGAN, MORROW, MUSKINGUM, NOBLE, OTTAWA, PAULDING, PERRY, PICKAWAY, PIKE, PORTAGE, PREBLE, PUTNAM, RICHLAND, ROSS, SANDUSKY, SCIOTO, SENECA, SHELBY, STARK, SUMMIT, TRUMBULL, TUSCARAWAS, UNION, VAN WERT, VINTON,

**Special Jurisdictional Note :**

**Details :**

(A) Highway Construction, Sewer, Waterworks And Utility Construction, Industrial & Building Site Heavy Construction, Airport Construction Or Railroad Construction Work.

(B) Power Plant, Tunnels, Amusement Park, Athletic Stadium Site Work ,Pollution Control,Sewer Plant, Waste Plant, & Water Treatment Facilities, Construction.

# Prevailing Wage Rate Skilled Crafts

Name of Union: Cement Mason Local 404

Change # : LCN01-2019fbLoc404

Craft : Cement Effective Date : 05/23/2019 Last Posted : 05/23/2019

	BHR		Fringe Benefit Payments					Irrevocable Fund		Total PWR	Overtime Rate	
			H&W	Pension	App Tr.	Vac.	Annuity	Other	LECET (*)			MISC (*)
Classification												
Cement Mason	\$31.50		\$8.45	\$6.35	\$0.47	\$0.00	\$5.09	\$0.19	\$0.00	\$0.00	\$52.05	\$67.80
Apprentice	Percent											
1st yr	58.05	\$18.29	\$8.45	\$6.35	\$0.47	\$0.00	\$2.55	\$0.19	\$0.00	\$0.00	\$36.30	\$45.44
2nd yr	73.05	\$23.01	\$8.45	\$6.35	\$0.47	\$0.00	\$2.55	\$0.19	\$0.00	\$0.00	\$41.02	\$52.53
3rd yr	83.08	\$26.17	\$8.45	\$6.35	\$0.47	\$0.00	\$2.55	\$0.19	\$0.00	\$0.00	\$44.18	\$57.27

**Special Calculation Note :** Other is Training Fund

**Ratio :**

5 Journeymen to 1 Apprentice  
2 Journeymen to 1 Apprentice

**Jurisdiction ( \* denotes special jurisdictional note ) :**

ASHTABULA, CUYAHOGA, GEAUGA, LAKE,  
LORAIN

**Special Jurisdictional Note :**

**Details :**

# Prevailing Wage Rate Skilled Crafts

Name of Union: Cement Mason Local 5 (Lorain Only)

Change # : LCN01-2010jcLoc5

Craft : Cement Effective Date : 07/14/2010 Last Posted : 07/14/2010

	BHR		Fringe Benefit Payments						Irrevocable Fund		Total PWR	Overtime Rate
			H&W	Pension	App Tr.	Vac.	Annuity	Other	LECET (*)	MISC (*)		
Classification												
Cement Mason	\$30.41		\$6.35	\$5.23	\$0.63	\$0.00	\$0.00	\$0.00			\$42.62	\$57.83
Apprentice	Percent											
1st 6 months	50.00	\$15.21	\$6.35	\$0.00	\$0.00	\$0.00	\$0.00	\$0.00			\$21.55	\$29.16
2nd 6 months	55.00	\$16.73	\$6.35	\$5.23	\$0.63	\$0.00	\$0.00	\$0.00			\$28.94	\$37.30
3rd 6 months	60.00	\$18.25	\$6.35	\$5.23	\$0.63	\$0.00	\$0.00	\$0.00			\$30.46	\$39.58
4th 6 months	65.00	\$19.77	\$6.35	\$5.23	\$0.63	\$0.00	\$0.00	\$0.00			\$31.98	\$41.86
5th 6 months	70.00	\$21.29	\$6.35	\$5.23	\$0.63	\$0.00	\$0.00	\$0.00			\$33.50	\$44.14
6th 6 months	75.00	\$22.81	\$6.35	\$5.23	\$0.63	\$0.00	\$0.00	\$0.00			\$35.02	\$46.42
7th 6 months	80.00	\$24.33	\$6.35	\$5.23	\$0.63	\$0.00	\$0.00	\$0.00			\$36.54	\$48.70
8th 6 months	85.00	\$25.85	\$6.35	\$5.23	\$0.63	\$0.00	\$0.00	\$0.00			\$38.06	\$50.98

**Special Calculation Note :** No special calculations for this skilled craft wage rate are required at this time.

**Ratio :**

- 5 Journeyman to 1 Apprentice
- 10 Journeyman to 2 Apprentices
- 15 Journeyman to 2 Apprentices
- 20 Journeyman to 4 Apprentices
- 25 Journeyman to 5 Apprentices

**Jurisdiction ( \* denotes special jurisdictional note ) :**  
LORAIN

**Special Jurisdictional Note :**

**Details :**

Worker shall finish all concrete construction, such as buildings, bridges, silos, elevators, smokestacks, curbs, gutters, sidewalks, roofs, mass reinforced concrete slabs and

all flat surfaces of cement.

The operation and control of all type's of vacuum mats used in the drying of cement floors in preparing same for machines, mastic or composition flooring, when laid free hand. Finishing or washing of all concrete construction, using any color pigment when mixed with cement in any other form composition, magnesite rubbing and grinding and nail coat weather done by brush, broom, trowel float or any other process including operation of machine for the scoring of floors, or any other purpose they may be used for in connection with the trade.

Rodding, spreading and tamping of all concrete spreading off all top materials, sills, copings, steps, stairs, and risers and running all cement magnesite composition, oxide chloride & plastic materials (6" base or less). All preparatory work on concrete construction to be finished or rubbed, such as cutting nails, wires, wall ties, etc. machine or carborundum stone on all concrete construction, setting of all strips, stakes and grades. The operation or all cement guns, the cement nozzle and finishing all material applied by gun. Laying and finishing gypsum material roof.

.All dry packing, grouting & finishing in connection with setting all machinery, such as engines, pumps, generators, air compressors tanks and so fourth that are set on concrete foundations. Waterproofing concrete foundations when using a cement base.

The work of grading concrete with a rake when brought to grade. Curing finished concrete by chemical compounds. Setting and nailing all expansion strips for concrete floors in buildings, sidewalks, and driveways, setting all metal forms regardless of height, cutting and sawing joints, whether done by hand or machine, filling of all joints, grouting of all machinery, plates and anchor bolts. Worker shall have the right to use all the tools necessary to complete his work. All form work not composed of any more than one piece of material shall be set by worker.

When pouring concrete slabs or any concrete, the surface of which is to be struck off to a given line, all workers necessary to finish same shall start at work when the pour begins. This applies also to pouring of topping on old slabs or any other surface. Curing, hardeners and sealers used on finished concrete wherever necessary, whether by chemical compounds or otherwise, shall be the work of cement mason.

Spreading, darbying, trowelling, screeding or all types of magnesium oxychloride cement composition floors, shall be work of cement mason. The preparation of all sub-floor surfaces, bonding, the preparation and installation of ground not be defeated.

No restriction on the use of the finishing or floating machines.

Using concrete saws for cutting construction joints on new work, and filling such joints with material such as latex, epoxies, lead, mastic, tar and similar material shall be done. Curing of all kinds water, burlap, and all emulsion spray cures.

# Prevailing Wage Rate Skilled Crafts

**Name of Union: Cement Mason Statewide HevHwy Exhibit A District II**

**Change # : OCN01-2021fbCementHevHwy**

**Craft : Cement Mason Effective Date : 05/01/2021 Last Posted : 04/23/2021**

	BHR		Fringe Benefit Payments					Irrevocable Fund		Total PWR	Overtime Rate	
			H&W	Pension	App Tr.	Vac.	Annuity	Other	LECET (*)			MISC (*)
<b>Classification</b>												
Cement Mason	\$31.15		\$8.25	\$7.35	\$0.65	\$0.00	\$2.25	\$0.07	\$0.00	\$0.00	\$49.72	\$65.29
<b>Apprentice</b>	<b>Percent</b>											
1st Year	70.00	\$21.80	\$8.25	\$7.35	\$0.65	\$0.00	\$2.25	\$0.07	\$0.00	\$0.00	\$40.37	\$51.28
2nd Year	80.00	\$24.92	\$8.25	\$7.35	\$0.65	\$0.00	\$2.25	\$0.07	\$0.00	\$0.00	\$43.49	\$55.95
3rd Year	90.00	\$28.03	\$8.25	\$7.35	\$0.65	\$0.00	\$2.25	\$0.07	\$0.00	\$0.00	\$46.60	\$60.62

**Special Calculation Note :** Other \$0.07 is for International Training Fund

**Ratio :**

1 Journeymen to 1 Apprentice  
2 to 1 thereafter

**Jurisdiction ( \* denotes special jurisdictional note ) :**

ALLEN, AUGLAIZE, BROWN, BUTLER, CARROLL, CLERMONT, COLUMBIANA, DEFIANCE, ERIE, HAMILTON, HARDIN, HIGHLAND, HOLMES, HURON, LOGAN, LORAIN, MAHONING, MEDINA, MERCER, OTTAWA, PAULDING, PORTAGE, SANDUSKY, SENECA, STARK, SUMMIT, TRUMBULL, TUSCARAWAS, VAN WERT, WARREN, WAYNE, WILLIAMS

**Special Jurisdictional Note :** (A) Highway Construction, Sewer, Waterworks And Utility Construction, Industrial & Building Site, Heavy Construction, Airport Construction Or Railroad Construction Work.

**Details :**

# Prevailing Wage Rate Skilled Crafts

**Name of Union: Cement Mason Statewide HevHwy Exhibit B District II**

**Change # : OCN01-2021fbCementHevHwy**

**Craft : Cement Mason Effective Date : 05/01/2021 Last Posted : 04/23/2021**

	BHR		Fringe Benefit Payments					Irrevocable Fund		Total PWR	Overtime Rate	
			H&W	Pension	App Tr.	Vac.	Annuity	Other	LECET (*)			MISC (*)
<b>Classification</b>												
Cement Mason	\$32.02		\$8.25	\$7.35	\$0.65	\$0.00	\$2.25	\$0.07	\$0.00	\$0.00	\$50.59	\$66.60
<b>Apprentice</b>												
	<b>Percent</b>											
1st Year	70.00	\$22.41	\$8.25	\$7.35	\$0.65	\$0.00	\$2.25	\$0.07	\$0.00	\$0.00	\$40.98	\$52.19
2nd Year	80.00	\$25.62	\$8.25	\$7.35	\$0.65	\$0.00	\$2.25	\$0.07	\$0.00	\$0.00	\$44.19	\$56.99
3rd Year	90.00	\$28.82	\$8.25	\$7.35	\$0.65	\$0.00	\$2.25	\$0.07	\$0.00	\$0.00	\$47.39	\$61.80

**Special Calculation Note :** Other \$0.07 is for International Training Fund.

**Ratio :**

1 Journeymen to 1 Apprentice  
2 to 1 thereafter

**Jurisdiction ( \* denotes special jurisdictional note ) :**

ALLEN, AUGLAIZE, BROWN, BUTLER, CARROLL, CLERMONT, COLUMBIANA, DEFIANCE, ERIE, HAMILTON, HARDIN, HIGHLAND, HOLMES, HURON, LOGAN, LORAIN, MAHONING, MEDINA, MERCER, OTTAWA, PAULDING, PORTAGE, SANDUSKY, SENECA, STARK, SUMMIT, TRUMBULL, TUSCARAWAS, VAN WERT, WARREN, WAYNE, WILLIAMS

**Special Jurisdictional Note :** (B) Power Plant, Tunnels, Amusement Park, Athletic Stadium Site Work ,Pollution Control,Sewer Plant, Waste Plant, & Water Treatment Facilities, Construction.

**Details :**

# Prevailing Wage Rate Skilled Crafts

**Name of Union: Electrical Local 71  
DOT Traffic Signal Highway Lighting Cleveland**

**Change # : LCN1-2021fbLoc71DOTClev**

**Craft : Lineman Effective Date : 03/16/2021 Last Posted : 03/16/2021**

	BHR		Fringe Benefit Payments					Irrevocable Fund		Total PWR	Overtime Rate	
			H&W	Pension	App Tr.	Vac.	Annuity	Other	LECET (*)			MISC (*)
<b>Classification</b>												
Electrical Lineman	\$38.33		\$6.75	\$1.15	\$0.38	\$0.00	\$8.05	\$0.00	\$0.00	\$0.00	\$54.66	\$73.82
Traffic Signal & Lighting Journeyman	\$38.33		\$6.75	\$1.15	\$0.38	\$0.00	\$8.05	\$0.00	\$0.00	\$0.00	\$54.66	\$73.82
Equipment Operator	\$34.49		\$6.75	\$1.03	\$0.34	\$0.00	\$7.24	\$0.00	\$0.00	\$0.00	\$49.85	\$67.09
Groundman 0 to 1 Year	\$23.00		\$6.75	\$0.69	\$0.23	\$0.00	\$4.83	\$0.00	\$0.00	\$0.00	\$35.50	\$47.00
Groundman 1 Year or more	\$26.83		\$6.75	\$0.80	\$0.27	\$0.00	\$5.63	\$0.00	\$0.00	\$0.00	\$40.28	\$53.70
<b>Traffic Apprentice</b>												
	<b>Percent</b>											
1st 1,000 Hours	60.00	\$23.00	\$6.75	\$0.69	\$0.23	\$0.00	\$4.83	\$0.00	\$0.00	\$0.00	\$35.50	\$47.00
2nd 1,000 Hours	65.00	\$24.91	\$6.75	\$0.75	\$0.25	\$0.00	\$5.23	\$0.00	\$0.00	\$0.00	\$37.89	\$50.35
3rd 1,000 Hours	70.01	\$26.83	\$6.75	\$0.80	\$0.27	\$0.00	\$5.63	\$0.00	\$0.00	\$0.00	\$40.28	\$53.70
4th 1,000 Hours	75.00	\$28.75	\$6.75	\$0.86	\$0.29	\$0.00	\$6.04	\$0.00	\$0.00	\$0.00	\$42.69	\$57.06
5th 1,000 Hours	80.00	\$30.66	\$6.75	\$0.92	\$0.31	\$0.00	\$6.44	\$0.00	\$0.00	\$0.00	\$45.08	\$60.42
6th 1,000 Hours	90.00	\$34.50	\$6.75	\$1.04	\$0.35	\$0.00	\$7.25	\$0.00	\$0.00	\$0.00	\$49.89	\$67.14

**Special Calculation Note :**

**Ratio :**  
1 Journeymen to 1 Apprentice

**Jurisdiction ( \* denotes special jurisdictional note ) :**  
ASHTABULA, CUYAHOGA, GEAUGA, LAKE,  
LORAIN

## **Special Jurisdictional Note :**

### **Details :**

A groundman when directed shall assist a Journeymen in the performance of his/her work on the ground, including the use of hand tools. Under no circumstances shall this classification climb poles, towers, ladders, or work from an elevated platform or bucket truck. This classification shall not perform work normally assigned to an apprentice lineman. There shall be no more than one (1) Groundman for each two (2) Journeyman except when performing DOT Traffic Signal or Highway lighting work where the ratio can be two (2) Groundman for each Journeyman or Operator.

# Prevailing Wage Rate Skilled Crafts

**Name of Union: Electrical Local 71 Cleveland Commercial Projects**

**Change # : LCN1-2021fbLoc71Clev**

**Craft : Lineman Effective Date : 03/16/2021 Last Posted : 03/16/2021**

	BHR		Fringe Benefit Payments					Irrevocable Fund		Total PWR	Overtime Rate	
			H&W	Pension	App Tr.	Vac.	Annuity	Other	LECET (*)			MISC (*)
Classification												
Electrical Lineman	\$50.76		\$6.75	\$1.52	\$0.51	\$0.00	\$11.67	\$0.40	\$0.00	\$0.00	\$71.61	\$96.99
Cable Splicer	\$50.76		\$6.75	\$1.52	\$0.50	\$0.00	\$10.67	\$0.40	\$0.00	\$0.00	\$70.60	\$95.98
Equip. Operator	\$45.68		\$6.75	\$1.37	\$0.46	\$0.00	\$10.51	\$0.40	\$0.00	\$0.00	\$65.17	\$88.01
Groundman 0 to 12 months	\$30.46		\$6.75	\$0.91	\$0.30	\$0.00	\$7.01	\$0.40	\$0.00	\$0.00	\$45.83	\$61.06
Groundman 1 year plus	\$35.53		\$6.75	\$1.07	\$0.36	\$0.00	\$8.17	\$0.40	\$0.00	\$0.00	\$52.28	\$70.04
Apprentice Linemen	Percent											
1st 1000 Hrs	60.00	\$30.46	\$6.75	\$0.91	\$0.30	\$0.00	\$7.01	\$0.40	\$0.00	\$0.00	\$45.83	\$61.05
2nd 1000 Hrs	65.00	\$32.99	\$6.75	\$0.99	\$0.33	\$0.00	\$7.59	\$0.40	\$0.00	\$0.00	\$49.05	\$65.55
3rd 1000 Hrs	70.00	\$35.53	\$6.75	\$1.07	\$0.36	\$0.00	\$8.17	\$0.40	\$0.00	\$0.00	\$52.28	\$70.05
4th 1000 Hrs	75.00	\$38.07	\$6.75	\$1.14	\$0.38	\$0.00	\$8.76	\$0.40	\$0.00	\$0.00	\$55.50	\$74.54
5th 1000 Hrs	80.00	\$40.61	\$6.75	\$1.22	\$0.41	\$0.00	\$9.34	\$0.40	\$0.00	\$0.00	\$58.73	\$79.03
6th 1000 Hrs	85.00	\$43.15	\$6.75	\$1.29	\$0.43	\$0.00	\$9.92	\$0.40	\$0.00	\$0.00	\$61.94	\$83.51
7th 1000 Hrs	90.00	\$45.68	\$6.75	\$1.37	\$0.46	\$0.00	\$10.51	\$0.40	\$0.00	\$0.00	\$65.17	\$88.02

**Special Calculation Note : Other is Health Reimbursement Account**

**Ratio :**

1 Journeymen to 1 Apprentice

**Jurisdiction ( \* denotes special jurisdictional note ) :**

ASHTABULA, CUYAHOGA, GEAUGA, LAKE, LORAIN

## **Special Jurisdictional Note :**

### **Details :**

A groundman when directed shall assist a Journeymen in the performance of his/her work on the ground, including the use of hand tools. Under no circumstances shall this classification climb poles, towers, ladders, or work from an elevated platform or bucket truck. This classification shall not perform work normally assigned to an apprentice lineman. There shall be no more than one (1) Groundman for each two (2) Journeyman except when performing DOT Traffic Signal or Highway lighting work where the ratio can be two (2) Groundman for each Journeyman or Operator.

# Prevailing Wage Rate Skilled Crafts

**Name of Union: Electrical Local 71 Cleveland Municipal Power & Transit**

**Change # : LCON1-2021fbLoc71Clev**

**Craft : Lineman Effective Date : 03/16/2021 Last Posted : 03/16/2021**

	BHR		Fringe Benefit Payments					Irrevocable Fund		Total PWR	Overtime Rate	
			H&W	Pension	App Tr.	Vac.	Annuity	Other	LECET (*)			MISC (*)
Classification												
Electrical Lineman	\$47.73		\$6.75	\$1.43	\$0.48	\$0.00	\$10.50	\$0.40	\$0.00	\$0.00	\$67.29	\$91.16
Cable Splicer	\$47.73		\$6.75	\$1.43	\$0.48	\$0.00	\$10.50	\$0.40	\$0.00	\$0.00	\$67.29	\$91.16
Equip. Operator	\$42.96		\$6.75	\$1.29	\$0.43	\$0.00	\$9.45	\$0.40	\$0.00	\$0.00	\$61.28	\$82.76
Groundman 0 to 12 months	\$28.64		\$6.75	\$0.86	\$0.29	\$0.00	\$6.30	\$0.40	\$0.00	\$0.00	\$43.24	\$57.56
Groundman 1 Year or More	\$33.41		\$6.75	\$1.00	\$0.33	\$0.00	\$7.35	\$0.40	\$0.00	\$0.00	\$49.24	\$65.94
Apprentice Linemen	Percent											
1st 1000 Hrs	60.00	\$28.64	\$6.75	\$0.86	\$0.29	\$0.00	\$6.30	\$0.40	\$0.00	\$0.00	\$43.24	\$57.56
2nd 1000 Hrs	65.00	\$31.02	\$6.75	\$0.93	\$0.31	\$0.00	\$6.82	\$0.40	\$0.00	\$0.00	\$46.23	\$61.75
3rd 1000 Hrs	70.00	\$33.41	\$6.75	\$1.00	\$0.33	\$0.00	\$7.35	\$0.40	\$0.00	\$0.00	\$49.24	\$65.95
4th 1000 Hrs	75.00	\$35.80	\$6.75	\$1.07	\$0.36	\$0.00	\$7.88	\$0.40	\$0.00	\$0.00	\$52.26	\$70.16
5th 1000 Hrs	80.00	\$38.18	\$6.75	\$1.15	\$0.38	\$0.00	\$8.40	\$0.40	\$0.00	\$0.00	\$55.26	\$74.36
6th 1000 Hrs	85.00	\$40.57	\$6.75	\$1.22	\$0.41	\$0.00	\$8.93	\$0.40	\$0.00	\$0.00	\$58.28	\$78.57
7th 1000 Hrs	90.00	\$42.96	\$6.75	\$1.29	\$0.43	\$0.00	\$9.45	\$0.40	\$0.00	\$0.00	\$61.28	\$82.76

**Special Calculation Note : Other is Health Reimbursement Account**

**Ratio :**  
1 Journeymen to 1 Apprentice

**Jurisdiction ( \* denotes special jurisdictional note ) :**  
ASHTABULA, CUYAHOGA, GEAUGA, LAKE,  
LORAIN

## **Special Jurisdictional Note :**

### **Details :**

A groundman when directed shall assist a Journeyman in the performance of his/her work on the ground, including the use of hand tools. Under no circumstances shall this classification climb poles, towers, ladders, or work from an elevated platform or bucket truck. This classification shall not perform work normally assigned to an apprentice lineman. There shall be no more than one (1) Groundman for each two (2) Journeyman except when performing DOT Traffic Signal or Highway lighting work where the ratio can be two (2) Groundman for each Journeyman or Operator.

# Prevailing Wage Rate Skilled Crafts

Name of Union: Electrical Local 71 High Tension Pipe Type Cable

Change # : LCN01-2021fbLoc7

Craft : Lineman Effective Date : 03/16/2021 Last Posted : 03/16/2021

	BHR	Fringe Benefit Payments						Irrevocable Fund		Total PWR	Overtime Rate
		H&W	Pension	App Tr.	Vac.	Annuity	Other	LECET (*)	MISC (*)		
Classification											
Electrical Lineman	\$45.61	\$6.75	\$1.37	\$0.46	\$0.00	\$10.95	\$0.60	\$0.00	\$0.00	\$65.74	\$88.54
Certified Lineman Welder	\$45.61	\$6.75	\$1.37	\$0.46	\$0.00	\$10.95	\$0.60	\$0.00	\$0.00	\$65.74	\$88.54
Certified Cable Splicer	\$45.61	\$6.75	\$1.37	\$0.46	\$0.00	\$10.95	\$0.60	\$0.00	\$0.00	\$65.74	\$88.54
Operator A	\$40.88	\$6.75	\$1.23	\$0.41	\$0.00	\$9.81	\$0.60	\$0.00	\$0.00	\$59.68	\$80.12
Operator B	\$36.20	\$6.75	\$1.09	\$0.36	\$0.00	\$8.69	\$0.60	\$0.00	\$0.00	\$53.69	\$71.79
Operator C	\$29.12	\$6.75	\$0.87	\$0.29	\$0.00	\$6.99	\$0.60	\$0.00	\$0.00	\$44.62	\$59.18
Groundman 0-12 months Exp	\$22.81	\$6.75	\$0.68	\$0.23	\$0.00	\$5.47	\$0.60	\$0.00	\$0.00	\$36.54	\$47.94
Groundman 0-12 months Exp w/CDL	\$25.09	\$6.75	\$0.75	\$0.25	\$0.00	\$6.02	\$0.60	\$0.00	\$0.00	\$39.46	\$52.01
Groundman 1 yr or more	\$25.09	\$6.75	\$0.75	\$0.25	\$0.00	\$6.02	\$0.60	\$0.00	\$0.00	\$39.46	\$52.01
Groundman 1 yr or more w/CDL	\$29.65	\$6.75	\$0.85	\$0.28	\$0.00	\$6.50	\$0.60	\$0.00	\$0.00	\$44.63	\$59.46
Equipment Mechanic A	\$36.20	\$6.75	\$1.09	\$0.36	\$0.00	\$8.69	\$0.60	\$0.00	\$0.00	\$53.69	\$71.79
Equipment Mechanic B	\$32.66	\$6.75	\$0.98	\$0.33	\$0.00	\$7.84	\$0.60	\$0.00	\$0.00	\$49.16	\$65.49
Equipment Mechanic C	\$29.12	\$6.75	\$0.87	\$0.29	\$0.00	\$6.99	\$0.60	\$0.00	\$0.00	\$44.62	\$59.18
X-Ray Technician	\$45.61	\$6.75	\$1.37	\$0.46	\$0.00	\$10.95	\$0.60	\$0.00	\$0.00	\$65.74	\$88.54

Apprentice	Percent											
1st 1000 hrs	60.00	\$27.37	\$6.75	\$0.82	\$0.27	\$0.00	\$6.57	\$0.60	\$0.00	\$0.00	\$42.38	\$56.06
2nd 1000 hrs	65.00	\$29.65	\$6.75	\$0.89	\$0.30	\$0.00	\$7.12	\$0.60	\$0.00	\$0.00	\$45.31	\$60.13
3rd 1000 hrs	70.00	\$31.93	\$6.75	\$0.96	\$0.32	\$0.00	\$7.66	\$0.60	\$0.00	\$0.00	\$48.22	\$64.18
4th 1000 hrs	75.00	\$34.21	\$6.75	\$1.03	\$0.34	\$0.00	\$8.21	\$0.60	\$0.00	\$0.00	\$51.14	\$68.24
5th 1000 hrs	80.00	\$36.49	\$6.75	\$1.09	\$0.36	\$0.00	\$8.76	\$0.60	\$0.00	\$0.00	\$54.05	\$72.29
6th 1000 hrs	85.00	\$38.77	\$6.75	\$1.16	\$0.39	\$0.00	\$9.30	\$0.60	\$0.00	\$0.00	\$56.97	\$76.35
7th 1000 hrs	90.00	\$41.05	\$6.75	\$1.23	\$0.41	\$0.00	\$9.85	\$0.60	\$0.00	\$0.00	\$59.89	\$80.41

**Special Calculation Note :** Other is Health Retirement Account

**Operator "A"**

John Henry Rock Drill, D-6 (or equivalent) and above, Trackhoe Digger, (320 Track excavator), Cranes (greater then 25 tons and less than 45 tons).

**Operator "B"**

Cranes (greater than 6 tons and up to 25 tons), Backhoes, Road Tractor, Dozer up to D-5, Pressure Digger-wheeled or tracked, all Tension wire Stringing equipment.

**Operator "C"**

Trench, Backhoe, Riding type vibratory Compactor, Ground Rod Driver, Boom Truck (6 ton & below), Skid Steer Loaders, Material Handler.

\*All Operators of cranes 45 ton or larger shall be paid the journeyman rate of pay. \$0.30 is for Health Retirement Account.

**Ratio :**

1 Journeyman to 1 Apprentice

**Jurisdiction ( \* denotes special jurisdictional note ):**

ADAMS, ASHLAND, ASHTABULA, ATHENS, AUGLAIZE, BELMONT, BROWN, BUTLER, CARROLL, CHAMPAIGN, CLARK, CLERMONT, CLINTON, COLUMBIANA, COSHOCTON, CRAWFORD, CUYAHOGA, DARKE, DELAWARE, FAIRFIELD, FAYETTE, FRANKLIN, GALLIA, GEauga, GREENE, GUERNSEY, HAMILTON, HARRISON, HIGHLAND, HOCKING, HOLMES, JACKSON, JEFFERSON, KNOX, LAKE, LAWRENCE, LICKING, LOGAN, LORAIN, MADISON, MAHONING, MARION, MEDINA, MEIGS, MERCER, MIAMI, MONROE, MONTGOMERY, MORGAN, MORROW, MUSKINGUM, NOBLE, PERRY, PICKAWAY, PIKE, PORTAGE, PREBLE, RICHLAND, ROSS, SCIOTO, SHELBY, STARK, SUMMIT, TRUMBULL, TUSCARAWAS, UNION, VINTON, WARREN,

WASHINGTON, WAYNE

**Special Jurisdictional Note :**

**Details :**

Heli - Arc Welding will be paid \$.30 above Journeyman rate. Additional compensation of 10% over the Journeyman Lineman and Journeyman Technician for performing work on structures outside of buildings such as water towers, smoke stacks, radio and television towers, more than 75' above the ground.

# Prevailing Wage Rate Skilled Crafts

Name of Union: **Electrical Local 71 Outside Utility Power**

**Change # : LCN01-2021fbLoc7**

**Craft : Lineman Effective Date : 03/16/2021 Last Posted : 03/16/2021**

	BHR	Fringe Benefit Payments						Irrevocable Fund		Total PWR	Overtime Rate
		H&W	Pension	App Tr.	Vac.	Annuity	Other	LECET (*)	MISC (*)		
Classification											
Electrical Lineman	\$43.22	\$6.75	\$1.30	\$0.43	\$0.00	\$10.37	\$0.60	\$0.00	\$0.00	\$62.67	\$84.28
Substation Technician	\$43.22	\$6.75	\$1.30	\$0.43	\$0.00	\$10.37	\$0.60	\$0.00	\$0.00	\$62.67	\$84.28
Cable Splicer	\$45.26	\$6.75	\$1.36	\$0.45	\$0.00	\$10.86	\$0.60	\$0.00	\$0.00	\$65.28	\$87.91
Operator A	\$38.75	\$6.75	\$1.16	\$0.39	\$0.00	\$9.30	\$0.60	\$0.00	\$0.00	\$56.95	\$76.32
Operator B	\$34.27	\$6.75	\$1.03	\$0.34	\$0.00	\$8.22	\$0.60	\$0.00	\$0.00	\$51.21	\$68.34
Operator C	\$27.54	\$6.75	\$0.83	\$0.28	\$0.00	\$6.61	\$0.60	\$0.00	\$0.00	\$42.61	\$56.38
Groundman 0-12 months Exp	\$21.61	\$6.75	\$0.65	\$0.22	\$0.00	\$5.19	\$0.60	\$0.00	\$0.00	\$35.02	\$45.82
Groundman 0-12 months Exp w/CDL	\$23.77	\$6.75	\$0.71	\$0.24	\$0.00	\$5.70	\$0.60	\$0.00	\$0.00	\$37.77	\$49.66
Groundman 1 yr or more	\$23.77	\$6.75	\$0.71	\$0.24	\$0.00	\$5.70	\$0.60	\$0.00	\$0.00	\$37.77	\$49.66
Groundman 1 yr or more w/CDL	\$28.09	\$6.75	\$0.84	\$0.28	\$0.00	\$6.74	\$0.60	\$0.00	\$0.00	\$43.30	\$57.35
Equipment Mechanic A	\$34.27	\$6.75	\$1.03	\$0.34	\$0.00	\$8.22	\$0.60	\$0.00	\$0.00	\$51.21	\$68.34
Equipment Mechanic B	\$30.91	\$6.75	\$0.93	\$0.31	\$0.00	\$7.42	\$0.60	\$0.00	\$0.00	\$46.92	\$62.38
Equipment Mechanic C	\$27.54	\$6.75	\$0.83	\$0.28	\$0.00	\$6.61	\$0.60	\$0.00	\$0.00	\$42.61	\$56.38
Line Truck w/uuger	\$30.44	\$6.75	\$0.91	\$0.30	\$0.00	\$7.31	\$0.60	\$0.00	\$0.00	\$46.31	\$61.53
<b>Apprentice</b>	<b>Percent</b>										

1st 1000 hrs	60.00	\$25.93	\$6.75	\$0.78	\$0.26	\$0.00	\$6.22	\$0.60	\$0.00	\$0.00	\$40.54	\$53.51
2nd 1000 hrs	65.00	\$28.09	\$6.75	\$0.84	\$0.28	\$0.00	\$6.74	\$0.60	\$0.00	\$0.00	\$43.30	\$57.35
3rd 1000 hrs	70.00	\$30.25	\$6.75	\$0.91	\$0.30	\$0.00	\$7.26	\$0.60	\$0.00	\$0.00	\$46.07	\$61.20
4th 1000 hrs	75.00	\$32.42	\$6.75	\$0.97	\$0.32	\$0.00	\$7.78	\$0.60	\$0.00	\$0.00	\$48.84	\$65.04
5th 1000 hrs	80.00	\$34.58	\$6.75	\$1.04	\$0.35	\$0.00	\$8.30	\$0.60	\$0.00	\$0.00	\$51.62	\$68.90
6th 1000 hrs	85.00	\$36.74	\$6.75	\$1.10	\$0.37	\$0.00	\$8.82	\$0.60	\$0.00	\$0.00	\$54.38	\$72.75
7th 1000 hrs	90.00	\$38.90	\$6.75	\$1.17	\$0.39	\$0.00	\$9.34	\$0.60	\$0.00	\$0.00	\$57.15	\$76.60

**Special Calculation Note :** Other is Health Retirement Account

**Operator "A"**

John Henry Rock Drill, D-6 (or equivalent) and above, Trackhoe Digger, (320 Track excavator), Cranes (greater than 25 tons and less than 45 tons).

**Operator "B"**

Cranes (greater than 6 tons and up to 25 tons), Backhoes, Road Tractor, Dozer up to D-5, Pressure Digger-wheeled or tracked, all Tension wire Stringing equipment.

**Operator "C"**

Trench, Backhoe, Riding type vibratory Compactor, Ground Rod Driver, Boom Truck (6 ton & below), Skid Steer Loaders, Material Handler.

**Ratio :**

(1) Journeyman Lineman to (1) Apprentice

**Jurisdiction ( \* denotes special jurisdictional note ) :**

ADAMS, ASHLAND, ASHTABULA, ATHENS, AUGLAIZE, BELMONT, BROWN, BUTLER, CARROLL, CHAMPAIGN, CLARK, CLERMONT, CLINTON, COLUMBIANA, COSHOCTON, CRAWFORD, CUYAHOGA, DARKE, DELAWARE, FAIRFIELD, FAYETTE, FRANKLIN, GALLIA, GEAUGA, GREENE, GUERNSEY, HAMILTON, HARRISON, HIGHLAND, HOCKING, HOLMES, JACKSON, JEFFERSON, KNOX, LAKE, LAWRENCE, LICKING, LOGAN, LORAIN, MADISON, MAHONING, MARION, MEDINA, MEIGS, MERCER, MIAMI, MONROE, MONTGOMERY, MORGAN, MORROW, MUSKINGUM, NOBLE, PERRY, PICKAWAY, PIKE, PORTAGE, PREBLE, RICHLAND, ROSS, SCIOTO, SHELBY, STARK, SUMMIT, TRUMBULL, TUSCARAWAS, UNION, VINTON, WARREN, WASHINGTON, WAYNE

**Special Jurisdictional Note :** 0.30 is for Health Retirement Account.

**Details :**

Heli - Arc Welding will be paid \$.30 above Journeyman rate. Additional compensation of 10% over the Journeyman Lineman and Journeyman Technician for performing work on structures outside of buildings such as water towers,

smoke stacks, radio and television towers, more than 75' above the ground.

# Prevailing Wage Rate Skilled Crafts

Name of Union: Electrical Local 71 Voice Data Video Outside

Change # : LCR01-2017fbLoc71VDV

Craft : Voice Data Video Effective Date : 10/18/2017 Last Posted : 10/18/2017

	BHR	Fringe Benefit Payments						Irrevocable Fund		Total PWR	Overtime Rate
		H&W	Pension	App Tr.	Vac.	Annuity	Other	LECET (*)	MISC (*)		
Classification											
Electrical Installer Technician I	\$23.46	\$5.50	\$0.70	\$0.00	\$0.00	\$0.30	\$0.00	\$0.00	\$0.00	\$29.96	\$41.69
Installer Technician II	\$22.37	\$5.50	\$0.67	\$0.00	\$0.00	\$0.30	\$0.00	\$0.00	\$0.00	\$28.84	\$40.03
Equipment Operator I	\$22.37	\$5.50	\$0.67	\$0.00	\$0.00	\$0.30	\$0.00	\$0.00	\$0.00	\$28.84	\$40.03
Equipment Operator II	\$18.43	\$5.50	\$0.55	\$0.00	\$0.00	\$0.30	\$0.00	\$0.00	\$0.00	\$24.78	\$33.99
Installer /Repair Outside	\$22.37	\$5.50	\$0.67	\$0.00	\$0.00	\$0.30	\$0.00	\$0.00	\$0.00	\$28.84	\$40.03
Ground Driver W/CDL	\$15.83	\$5.50	\$0.47	\$0.00	\$0.00	\$0.30	\$0.00	\$0.00	\$0.00	\$22.10	\$30.01
Groundman	\$13.24	\$5.50	\$0.40	\$0.00	\$0.00	\$0.30	\$0.00	\$0.00	\$0.00	\$19.44	\$26.06
Cable Splicer	\$23.46	\$5.50	\$0.70	\$0.00	\$0.00	\$0.30	\$0.00	\$0.00	\$0.00	\$29.96	\$41.69

**Special Calculation Note :**

**Ratio :**

**Jurisdiction ( \* denotes special jurisdictional note ) :**

- ADAMS, ASHLAND, ASHTABULA, ATHENS,
- AUGLAIZE, BELMONT, BROWN, BUTLER,
- CARROLL, CHAMPAIGN, CLARK, CLERMONT,
- CLINTON, COLUMBIANA, COSHOCTON,
- CRAWFORD, CUYAHOGA, DARKE, DELAWARE,
- FAIRFIELD, FAYETTE, FRANKLIN, GALLIA,
- GEAUGA, GREENE, GUERNSEY, HAMILTON,
- HARRISON, HIGHLAND, HOCKING, HOLMES,
- JACKSON, JEFFERSON, KNOX, LAKE,
- LAWRENCE, LICKING, LOGAN, LORAIN,
- MADISON, MAHONING, MARION, MEDINA,
- MEIGS, MERCER, MIAMI, MONROE,

MONTGOMERY, MORGAN, MORROW,  
MUSKINGUM, NOBLE, PERRY, PICKAWAY, PIKE,  
PORTAGE, PREBLE, RICHLAND, ROSS, SCIOTO,  
SHELBY, STARK, SUMMIT, TRUMBULL,  
TUSCARAWAS, UNION, VINTON, WARREN,  
WASHINGTON, WAYNE

### Special Jurisdictional Note :

#### Details :

**Cable Splicer:** Inspect and test lines or cables, analyze results, and evaluate transmission characteristics. Cover conductors with insulation or seal splices with moisture-proof covering. Install, splice, test, and repair cables using tools or mechanical equipment. This will include the splicing of fiber.

**Journeyman Technician I:** Must know all aspects of telephone and cable work. This is to include aerial, underground, and manhole work. Must know how to climb and run bucket. Must have all the tools required to perform these tasks. Must be able to be responsible for the safety of the crew at all times. Must also have CDL license and have at least 5 years experience.

**Installer/Repairman:** Perform tasks of repairing, installing, and testing phone and CATV services.

**Technician II:** Have at least three years of telephone and CATV experience. Must have the knowledge of underground, aerial, and manhole work. Must be able to climb and operate bucket. Must have CDL. Must have all tools needed to perform these tasks.

**Equipment Operator I:** Able to operate a digger derrick or bucket truck. Have at least 5 years of experience and must have a valid CDL license.

**Equipment Operator II:** Able to operate a digger derrick or bucket truck. Have at least 3 years of experience and must have a valid CDL license.

**Groundman W/CDL:** Must have a valid CDL license and be able to perform tasks such as: climbing poles, pulling downguys, making up material, and getting appropriate tools for the job. Must have at least 5 year's experience.

**Groundman:** Perform tasks such as: climbing poles, pulling downguys, making up material, and getting appropriate tools for the job. Experience 0-5 years.

# Prevailing Wage Rate Skilled Crafts

Name of Union: Elevator Local 17

Change # : LCN01-2012jcLoc17

Craft : Elevator Effective Date : 05/30/2012 Last Posted : 05/30/2012

	BHR		Fringe Benefit Payments					Irrevocable Fund		Total PWR	Overtime Rate	
			H&W	Pension	App Tr.	Vac.	Annuity	Other	LECET (*)			MISC (*)
Classification												
Elevator Mechanic	\$44.04		\$11.02	\$6.96	\$0.55	\$2.64	\$5.00	\$1.43	\$0.00	\$0.00	\$71.64	\$93.66
Helper	\$30.83		\$11.02	\$6.96	\$0.55	\$1.85	\$5.00	\$0.99	\$0.00	\$0.00	\$57.20	\$72.61
<b>Apprentice</b>	<b>Percent</b>											
Apprentice												
0-6months Probation	50.00	\$22.02	\$0.00	\$0.00	\$0.00	\$0.00	\$0.00	\$0.00	\$0.00	\$0.00	\$22.02	\$33.03
1st year	55.00	\$24.22	\$11.02	\$6.96	\$0.55	\$1.42	\$5.00	\$0.78	\$0.00	\$0.00	\$49.95	\$62.06
2nd year	65.00	\$28.63	\$11.02	\$6.96	\$0.55	\$1.67	\$5.00	\$0.92	\$0.00	\$0.00	\$54.75	\$69.06
3rd year	70.00	\$30.83	\$11.02	\$6.96	\$0.55	\$1.80	\$5.00	\$0.99	\$0.00	\$0.00	\$57.15	\$72.56
4th year and Assistant Mechanic	80.00	\$35.23	\$11.02	\$6.96	\$0.55	\$2.06	\$5.00	\$1.14	\$0.00	\$0.00	\$61.96	\$79.58

**Special Calculation Note :** Vacation 6% for employees under 5 years based on regular hourly rate for all hours worked. 8% for employees over 5 years based on regular hourly rate for all hours worked. Other is Holiday Pay

**Ratio :**  
1 Journeyman to 1 Apprentice.

**Jurisdiction ( \* denotes special jurisdictional note ) :**  
ASHTABULA, CUYAHOGA, ERIE, GEAUGA, LAKE, LORAIN

**Special Jurisdictional Note :**

**Details :**

# Prevailing Wage Rate Skilled Crafts

Name of Union: Glazier Local 181

Change # : LCN01-2020fbLoc181

Craft : Glazier Effective Date : 07/02/2020 Last Posted : 07/02/2020

	BHR		Fringe Benefit Payments					Irrevocable Fund		Total PWR	Overtime Rate	
			H&W	Pension	App Tr.	Vac.	Annuity	Other	LECET (*)			MISC (*)
<b>Classification</b>												
Glazier	\$32.82		\$7.17	\$10.33	\$0.40	\$0.00	\$0.00	\$0.00	\$0.00	\$0.00	\$50.72	\$67.13
<b>Apprentice</b>	<b>Percent</b>											
1st 6 months	40.00	\$13.13	\$7.17	\$0.92	\$0.40	\$0.00	\$0.00	\$0.00	\$0.00	\$0.00	\$21.62	\$28.18
2nd 6 months	45.00	\$14.77	\$7.17	\$0.92	\$0.40	\$0.00	\$0.00	\$0.00	\$0.00	\$0.00	\$23.26	\$30.64
3rd 6 months	50.00	\$16.41	\$7.17	\$4.71	\$0.40	\$0.00	\$0.00	\$0.00	\$0.00	\$0.00	\$28.69	\$36.90
4th 6 months	55.00	\$18.05	\$7.17	\$5.08	\$0.40	\$0.00	\$0.00	\$0.00	\$0.00	\$0.00	\$30.70	\$39.73
5th 6 months	60.00	\$19.69	\$7.17	\$5.46	\$0.40	\$0.00	\$0.00	\$0.00	\$0.00	\$0.00	\$32.72	\$42.57
6th 6 months	70.00	\$22.97	\$7.17	\$6.22	\$0.40	\$0.00	\$0.00	\$0.00	\$0.00	\$0.00	\$36.76	\$48.25
7th 6 months	80.00	\$26.26	\$7.17	\$6.98	\$0.40	\$0.00	\$0.00	\$0.00	\$0.00	\$0.00	\$40.81	\$53.93
8th 6 months	90.00	\$29.54	\$7.17	\$7.73	\$0.40	\$0.00	\$0.00	\$0.00	\$0.00	\$0.00	\$44.84	\$59.61

**Special Calculation Note :** No special calculations for this classification.

**Ratio :**

2 Journeymen to 1 Apprentice  
3 Journeymen to 1 Apprentice Thereafter

**Jurisdiction ( \* denotes special jurisdictional note ):**

ASHTABULA, CUYAHOGA, ERIE\*, GEAUGA,  
HURON, LAKE, LORAIN, MEDINA\*, PORTAGE\*,  
SUMMIT\*

**Special Jurisdictional Note :** Start at the intersection of Route 305 and the eastern boundary line of Portage County. Follow Route 305 west onto Route 82, follow Route 82 west to the intersection of Routes 82,8 and 271, follow Route 271 south to Medina County line west to Route 94, follow Route 94 south to Route 303, follow Route 303 west to Route 252, follow Route 252 south to Route 18, follow Route 18 west to Route 301, follow 301 south to Route 162, follow Route 162 west to Route 58, follow Route 58 south to the Ashland County line, follow the Ashland County line. The eastern part of Route 4 north to Lake Erie is the jurisdiction of Local 181. Local 181 has the jurisdiction on all projects built on the property which borders on the above Routes and/or intersections, wherever a County line is the divider between Local 181 and another

Union, the jurisdiction is only to the county line.

**Details :**

High Pay: All work is defined for the purpose of the agreement as being work which requires that the employee be supported by equipment that hangs from or suspends from the wall or roof of a building or structure. This work shall receive an additional \$1.25 per hour.

# Prevailing Wage Rate Skilled Crafts

Name of Union: Ironworker Local 17

Change # : LCN01-2020fbLoc17

Craft : Ironworker Effective Date : 12/24/2020 Last Posted : 12/24/2020

	BHR		Fringe Benefit Payments					Irrevocable Fund		Total PWR	Overtime Rate	
			H&W	Pension	App Tr.	Vac.	Annuity	Other	LECET (*)			MISC (*)
Classification												
Ironworker	\$33.83		\$7.94	\$10.00	\$0.67	\$2.10	\$4.50	\$0.00	\$0.00	\$0.00	\$59.04	\$75.95
Apprentice	Percent											
1st 6 Months	50.00	\$16.91	\$7.94	\$10.00	\$0.67	\$2.10	\$4.50	\$0.00	\$0.00	\$0.00	\$42.13	\$50.58
2nd 6 Months	55.00	\$18.61	\$7.94	\$10.00	\$0.67	\$2.10	\$4.50	\$0.00	\$0.00	\$0.00	\$43.82	\$53.12
2nd Year 1st 6 Months	70.00	\$23.68	\$7.94	\$10.00	\$0.67	\$2.10	\$4.50	\$0.00	\$0.00	\$0.00	\$48.89	\$60.73
2nd Year 2nd 6 Months	75.00	\$25.37	\$7.94	\$10.00	\$0.67	\$2.10	\$4.50	\$0.00	\$0.00	\$0.00	\$50.58	\$63.27
3rd Year 1st 6 Months	80.00	\$27.06	\$7.94	\$10.00	\$0.67	\$2.10	\$4.50	\$0.00	\$0.00	\$0.00	\$52.27	\$65.81
3rd Year 2nd 6 Months	85.00	\$28.76	\$7.94	\$10.00	\$0.67	\$2.10	\$4.50	\$0.00	\$0.00	\$0.00	\$53.97	\$68.34
4th Year 1st 6 Months	90.00	\$30.45	\$7.94	\$10.00	\$0.67	\$2.10	\$4.50	\$0.00	\$0.00	\$0.00	\$55.66	\$70.88
4th Year 2nd 6 Months	95.00	\$32.14	\$7.94	\$10.00	\$0.67	\$2.10	\$4.50	\$0.00	\$0.00	\$0.00	\$57.35	\$73.42

**Special Calculation Note :** No special calculations for this skilled craft wage rate are required at this time.

**Ratio :**

- 4 Journeymen to 1 Apprentice on Structural Work
- 3 Journeymen to 1 Apprentice on Rod Work
- 2 Journeymen to 1 Apprentice on Finishing, Steel Sash, Stairway and Ornamental Work
- 1 Apprentice for every Sheeting Gang
- 1 Journeymen to 2 Apprentice Roadway Signage and Sound Barriers

**Jurisdiction ( \* denotes special jurisdictional note ):**

- ASHTABULA, CUYAHOGA, ERIE, GEAUGA, HURON, LAKE, LORAIN, MEDINA, PORTAGE, SUMMIT

## 2 Journeymen to 2 Apprentice Unloading and Erection of Light Gauge Metal Trusses

**Special Jurisdictional Note :** West Boundary Line :Sandusky, Ohio: Boundary lines between Local 17 & Local 55 are as follows: Columbus Ave north to Sandusky Bay (and/or Lake Erie): Columbus Ave South to present Route 4: Route 4 South to present Route 99: from Route 99 south to old Route 224-all territory to the west of the boundary line to be the jurisdiction of Local 55.All territory to the East of the boundary line to be the jurisdiction of Local 17.Kelly's Island to be within jurisdiction of Local 17.All bridges,tunnels,viaducts,etc, relative to these boundary lines shall be the jurisdiction of Local 17

South Boundary Line:Canton, Ohio: Boundary lines between Local 17 & Local 550 are as follows: All territory north of old Route 224 line to be the jurisdiction of Local 17. All bridges,tunnels,viaducts,signs,etc, relative to old Route 224 line to be within the jurisdiction of Local 17. All territory south of old Route 224 line is to be within the jurisdiction of Local 550, except for everything within the city limits of Barberton which shall be the jurisdiction of Local 17.

Reading from West to East: Route old 224 line: Greenwich Ave-Wooster Road or East Ave. Route old 224 line: New 224 line including Cloverleaf: East Waterloo Road: New 224 line-Attwood Road-Old 224. This will be considered to be the old Route 224 line,except for the city limits of Barberton, Ohio which shall be the jurisdiction of Local 17

Southeast Boundary : Between local 17 and Local 207 are as follows: West of a line from Middlefield to Shalersville to Deerfield, shall be under the jurisdiction of local 17. East of a line from Middlefield, to Shalersville to Deerfield, shall be under the jurisdiction of Local 207.

Local 17 & Local 207 have agreed that the Ohio County of Ashtabula shall be as follows: Everything North of Route 6, starting at the Geauga County line, proceeding east to State Route 45, shall be under the jurisdiction of Local 17. Everything South, starting at the Geauga County line shall be under local 207.

North Boundary: The East boundary line and the West boundary line continuing North halfway across Lake Erie.

**Details :**

# Prevailing Wage Rate Skilled Crafts

Name of Union: Labor HevHwy 2

Change # : LCN01-2021fbLaborHevHwy2

Craft : Laborer Group 1 Effective Date : 05/01/2021 Last Posted : 04/21/2021

	BHR		Fringe Benefit Payments					Irrevocable Fund		Total PWR	Overtime Rate	
			H&W	Pension	App Tr.	Vac.	Annuity	Other	LECET (*)			MISC (*)
Classification												
Laborer Group 1	\$33.70		\$7.50	\$3.90	\$0.45	\$0.00	\$0.00	\$0.00	\$0.10	\$0.00	\$45.65	\$62.50
Group 2	\$33.87		\$7.50	\$3.90	\$0.45	\$0.00	\$0.00	\$0.00	\$0.10	\$0.00	\$45.82	\$62.75
Group 3	\$34.20		\$7.50	\$3.90	\$0.45	\$0.00	\$0.00	\$0.00	\$0.10	\$0.00	\$46.15	\$63.25
Group 4	\$34.65		\$7.50	\$3.90	\$0.45	\$0.00	\$0.00	\$0.00	\$0.10	\$0.00	\$46.60	\$63.92
Watch Person	\$26.00		\$7.50	\$3.90	\$0.45	\$0.00	\$0.00	\$0.00	\$0.10	\$0.00	\$37.95	\$50.95
<b>Apprentice</b>	<b>Percent</b>											
0-1000 hrs	60.00	\$20.22	\$7.50	\$3.90	\$0.45	\$0.00	\$0.00	\$0.00	\$0.10	\$0.00	\$32.17	\$42.28
1001-2000 hrs	70.02	\$23.60	\$7.50	\$3.90	\$0.45	\$0.00	\$0.00	\$0.00	\$0.10	\$0.00	\$35.55	\$47.35
2001-3000 hrs	80.00	\$26.96	\$7.50	\$3.90	\$0.45	\$0.00	\$0.00	\$0.00	\$0.10	\$0.00	\$38.91	\$52.39
3001-4000 hrs	90.00	\$30.33	\$7.50	\$3.90	\$0.45	\$0.00	\$0.00	\$0.00	\$0.10	\$0.00	\$42.28	\$57.45
More Than 4000 hrs	100.00	\$33.70	\$7.50	\$3.90	\$0.45	\$0.00	\$0.00	\$0.00	\$0.10	\$0.00	\$45.65	\$62.50

**Special Calculation Note :** Watchman has no Apprentices. Tunnel Laborer rate with air-pressurized add \$1.00 to the above wage rate.

**Ratio :**

1 Journeymen to 1 Apprentice  
3 Journeymen to 1 Apprentice thereafter

**Jurisdiction ( \* denotes special jurisdictional note ):**

ASHTABULA, ERIE, HURON, LORAIN, LUCAS, MAHONING, MEDINA, OTTAWA, PORTAGE, SANDUSKY, STARK, SUMMIT, TRUMBULL, WOOD

**Special Jurisdictional Note :** Hod Carriers and Common Laborers - Heavy, Highway, Sewer, Waterworks, Utility, Airport, Railroad, Industrial and Building Site, Sewer Plant, Waste Water Treatment Facilities Construction

**Details :**

Group 1  
Laborer (Construction); Plant Laborer or Yardman, Right-of-way Laborer, Landscape Laborer, Highway Lighting

Worker, Signalization Worker, (Swimming) Pool Construction Laborer, Utility Man, \*Bridge Man, Handyman, Joint Setter, Flagperson, Carpenter Helper, Waterproofing Laborer, Slurry Seal, Seal Coating, Surface Treatment or Road Mix Laborer, Riprap Laborer & Grouter, Asphalt Laborer, Dump Man (batch trucks), Guardrail & Fence Installer, Mesh Handler & Placer, Concrete Curing Applicator, Scaffold Erector, Sign Installer, Hazardous Waste (level D), Diver Helper, Zone Person and Traffic Control.

\*Bridge Man will perform work as per the October 31, 1949, memorandum on concrete forms, by and between the United Brotherhood of Carpenters and Joiners of America and the Laborers' International Union of North America, which states in; "the moving, cleaning, oiling and carrying to the next point of erection, and the stripping of forms which are not to be re-used, and forms on all flat arch work shall be done by members of the Laborers' International Union of North America."

#### Group 2

Asphalt Raker, Screwman or Paver, Concrete Puddler, Kettle Man (pipeline), All Machine-Driven Tools (Gas, Electric, Air), Mason Tender, Brick Paver, Mortar Mixer, Skid Steer, Sheeting & Shoring Person, Surface Grinder Person, Screedperson, Water Blast, Hand Held Wand, Power Buggy or Power Wheelbarrow, Paint Striper, Plastic fusing Machine Operator, Rodding Machine Operator, Pug Mill Operator, Operator of All Vacuum Devices Wet or Dry, Handling of all Pumps 4 inches and under (gas, air or electric), Diver, Form Setter, Bottom Person, Welder Helper (pipeline), Concrete Saw Person, Cutting with Burning Torch, Pipe Layer, Hand Spiker (railroad), Underground Person (working in sewer and waterline, cleaning, repairing and reconditioning). Tunnel Laborer (without air), Caisson, Cofferdam (below 25 feet deep), Air Track and Wagon Drill, Sandblaster Nozzle Person, Hazardous Waste (level B), \*\*\*Lead Abatement, Hazardous Waste (level C)

\*\*\*Includes the erecting of structures for the removal, including the encapsulation and containment of Lead abatement process.

#### Group 3

Blast and Powder Person, Muckers will be defined as shovel men working directly with the miners, Wrencher (mechanical joints & utility pipeline), Yarnier, Top Lander, Hazardous Waste (level A), Concrete Specialist, Curb Setter and Cutter, Grade Checker, Concrete Crew in Tunnels. Utility pipeline Tappers, Waterline, Caulker, Signal Person will receive the rate equal to the rate paid the Laborer classification for which the Laborer is signaling.

#### Group 4

Miner, Welder, Gunite Nozzle Person

A.) The Watchperson shall be responsible to patrol and maintain a safe traffic zone including but not limited to barrels, cones, signs, arrow boards, message boards etc.

The responsibility of a watchperson is to see that the equipment, job and office trailer etc. are secure.

# Prevailing Wage Rate Skilled Crafts

Name of Union: Labor Local 758 Building

Change # : LCNO1-2021fbLoc530

Craft : Laborer Effective Date : 05/01/2021 Last Posted : 04/14/2021

	BHR		Fringe Benefit Payments					Irrevocable Fund		Total PWR	Overtime Rate	
			H&W	Pension	App Tr.	Vac.	Annuity	Other	LECET (*)			MISC (*)
<b>Classification</b>												
Laborer Group A	\$29.52		\$7.50	\$3.90	\$0.40	\$0.00	\$1.00	\$0.00	\$0.10	\$0.00	\$42.42	\$57.18
Laborer Group B	\$29.72		\$7.50	\$3.90	\$0.40	\$0.00	\$1.00	\$0.00	\$0.10	\$0.00	\$42.62	\$57.48
Laborer Group C	\$30.12		\$7.50	\$3.90	\$0.40	\$0.00	\$1.00	\$0.00	\$0.10	\$0.00	\$43.02	\$58.08
Laborer Group D	\$21.58		\$7.50	\$3.90	\$0.40	\$0.00	\$1.00	\$0.00	\$0.10	\$0.00	\$34.48	\$45.27
Laborer Group E	\$25.10		\$7.50	\$3.90	\$0.40	\$0.00	\$1.00	\$0.00	\$0.10	\$0.00	\$38.00	\$50.55
<b>Apprentice</b>	<b>Percent</b>											
0-1000 hrs	60.00	\$17.71	\$7.50	\$3.90	\$0.40	\$0.00	\$1.00	\$0.00	\$0.10	\$0.00	\$30.61	\$39.47
1001-2000	70.00	\$20.66	\$7.50	\$3.90	\$0.40	\$0.00	\$1.00	\$0.00	\$0.10	\$0.00	\$33.56	\$43.90
2001-3000	80.00	\$23.62	\$7.50	\$3.90	\$0.40	\$0.00	\$1.00	\$0.00	\$0.10	\$0.00	\$36.52	\$48.32
3001-4000	90.00	\$26.57	\$7.50	\$3.90	\$0.40	\$0.00	\$1.00	\$0.00	\$0.10	\$0.00	\$39.47	\$52.75
More than 4000 hrs	100.00	\$29.52	\$7.50	\$3.90	\$0.40	\$0.00	\$1.00	\$0.00	\$0.10	\$0.00	\$42.42	\$57.18

**Special Calculation Note :** No special calculations for this skilled craft wage rate are required at this time.

**Ratio :**

1 Journeyman to 1 Apprentice  
3 Journeyman to 1 Apprentice

**Jurisdiction ( \* denotes special jurisdictional note ) :**  
LORAIN

**Special Jurisdictional Note :**

**Details :**

Classification Description :

Group 1  
Building and Construction Laborer, Asbestos Removal, Lead Abatement, Hazardous Waste Removal, Signalman, Tool Cribman, Carpenter Tenders, Finisher Tender, Deep Cleaning, Concrete Handler, Utility Construction Laborer, Guard Rail Erector

Group 2

Bottom man, Scaffold Builders, Tunnel Laborer, Pipe Layer, Air and Power Driven Tools, Burner on Demolition Work, Swinging Scaffold, Mucker, Caisson Worker, Cofferdam Worker, Powder Man and Dynamite Blasters, Creosote Work, Mortar Mixer, Form Setter, Mason Tender, Plaster Tender, Hod Carrier, Laser Beam Set-up Man, Concrete Tender, . All work involving refractory materials including demolition of refractory materials.

Group 3

Gunnite Operation, Lancer, Bellman, Hook-up Man on Blast Furnace Work and Toxic/Hazardous Waste

Group 4

Watchman

Group 5

Parking, Grading, Landscaping and General Clean-up

# Prevailing Wage Rate Skilled Crafts

**Name of Union: Operating Engineers - Building Local 18 - Zone I (A)**

**Change # : LCN02-2020fbLoc18**

**Craft : Operating Engineer Effective Date : 07/02/2020 Last Posted : 07/02/2020**

	BHR		Fringe Benefit Payments					Irrevocable Fund		Total PWR	Overtime Rate	
			H&W	Pension	App Tr.	Vac.	Annuity	Other	LECET (*)			MISC (*)
Classification												
Operator Class 1	\$41.91		\$8.51	\$6.00	\$0.85	\$0.00	\$0.00	\$0.14	\$0.00	\$0.00	\$57.41	\$78.36
Class 2	\$41.76		\$8.51	\$6.00	\$0.85	\$0.00	\$0.00	\$0.14	\$0.00	\$0.00	\$57.26	\$78.14
Class 3	\$40.31		\$8.51	\$6.00	\$0.85	\$0.00	\$0.00	\$0.14	\$0.00	\$0.00	\$55.81	\$75.96
Class 4	\$39.53		\$8.51	\$6.00	\$0.85	\$0.00	\$0.00	\$0.14	\$0.00	\$0.00	\$55.03	\$74.79
Class 5	\$39.21		\$8.51	\$6.00	\$0.85	\$0.00	\$0.00	\$0.14	\$0.00	\$0.00	\$54.71	\$74.31
Class 6	\$32.13		\$8.51	\$6.00	\$0.85	\$0.00	\$0.00	\$0.14	\$0.00	\$0.00	\$47.63	\$63.70
Class 7	\$42.91		\$8.51	\$6.00	\$0.85	\$0.00	\$0.00	\$0.14	\$0.00	\$0.00	\$58.41	\$79.86
Class 8	\$42.91		\$8.51	\$6.00	\$0.85	\$0.00	\$0.00	\$0.14	\$0.00	\$0.00	\$58.41	\$79.86
Class 9	\$43.41		\$8.51	\$6.00	\$0.85	\$0.00	\$0.00	\$0.14	\$0.00	\$0.00	\$58.91	\$80.61
Apprentice	Percent											
1st Year	60.00	\$25.15	\$8.51	\$6.00	\$0.85	\$0.00	\$0.00	\$0.14	\$0.00	\$0.00	\$40.65	\$53.22
2nd Year	70.00	\$29.34	\$8.51	\$6.00	\$0.85	\$0.00	\$0.00	\$0.14	\$0.00	\$0.00	\$44.84	\$59.51
3rd Year	80.00	\$33.53	\$8.51	\$6.00	\$0.85	\$0.00	\$0.00	\$0.14	\$0.00	\$0.00	\$49.03	\$65.79
4th Year	90.00	\$37.72	\$8.51	\$6.00	\$0.85	\$0.00	\$0.00	\$0.14	\$0.00	\$0.00	\$53.22	\$72.08

**Special Calculation Note :** Other: Education & Safety and National Training Fund.

**Ratio :** **Jurisdiction ( \* denotes special jurisdictional note ):**

For every (3) Operating Engineer Journeymen employed by ASHTABULA, CUYAHOGA, ERIE, GEAUGA, HURON, the company ,there may be employed (1) Registered Apprentice. An apprentice, while employed as part of a crew per Article VIII, paragraph77, will not be subject to the apprenticeship ratios in this collective bargaining agreement.

**Special Jurisdictional Note :**

**Details :**

Note: There will be a 5% increase for the apprentices on top of the percentages listed above provided they are operating mobile equipment. Operating Engineers employed on any piece of equipment requiring a Certified Crane Operator (CCO) certification or employed on cranes involved in pile driving operations shall be paid a premium of one dollar (\$1.00) per hour in addition to the crane rate or any escalated rate that may be in effect.

Class 1 - A-Frames; " Boiler Operators, Compressor Operators, Hydraulic Pumps & Power Pacs when mounted on a crane or regardless of where said equipment is mounted (piggy-back operator)"; Boom Trucks (all types); Cableways; Cherry Pickers; Combination - Concrete Mixers & Towers; Concrete Pumps; Cranes (all types); Cranes- compact: Track or rubber over 4000lbs. capacity; Cranes- self erecting: stationary, track or truck (all configurations); Derricks (all types); Draglines; Dredges (dipper, clam or suction) 3-man crew; Elevating Graders or Euclid Loaders; Floating Equipment; Gradalls; Helicopter Operators, hoisting building materials; Helicopter Winch Operators, hoisting building materials; Hoes (All types); Hoists (with two or more drums in use); Lift Slab or Panel Jack Operators; Locomotives (all types); Maintenance Engineers (Mechanic and/or Welder); Mixers, paving (multiple drum); Mobile Concrete Pumps with booms; Panelboards, (all types on site); Pile Drivers; Power Shovels; Robotics Equipment Operator/Mechanic; Rotary Drills (all), used on caissons work, wells (all types), Geothermal work and sub-structure work; Rough Terrain Forklifts with Winch/Hoist (when used as a crane); Side Booms; Slip Form Pavers; Straddle Carriers (Building Construction on site); Tug Boats; Tunnel Boring Machine (TBM).

Class 2 - Asphalt Pavers; Bulldozers; CMI type Equipment; Endloaders; Horizontal Directional Drill Locator; Horizontal Directional Drill Operator; Instrument Man; Kolman-type Loaders (Dirt Loading); Lead Greasemen; Mucking Machines; Power Graders; Power Scoops; Power Scrapers; Push Cats; Rotomills; Vermeer Type Concrete Saw.

Class 3 - Air Compressors, Pressurizing Shafts or Tunnels; Articulating/Straight bed dumps if assigned by the employer (minus \$4.00 per hour from Class C); All Asphalt Rollers; Fork Lifts; Hoists (with one drum); House Elevators (except those automatic call button controlled); Hydro Excavator (all types C rate) (F rate if a second person is needed) Helper rate; Laser Screeds and like equipment; Man Lifts; Modular Moving and Placement machine (C Rate) (F Rate if second person is needed); Mud Jacks; Portable Hydraulic Gantry (lift system C rate) (F Rate if a second person is needed); Power Boilers (over 15 lbs. pressure); Portable Hydraulic Gantry (lift system C Rate) (F rate if a second person is needed); Pump Operators (installing or operating Well Points or other types of Dewatering Systems); Pressure Grouting; Trenchers (24" and under); Utility Operators.

Class 4 – Brokks with a manufacture's weight of 3,500 lbs. and above; Compressors, on building construction; Conveyors, used for handling building materials; Generators; Gunite Machines; Mixers, more than one bag capacity ; Mixers, one bag capacity (side loader); ;Pavement Breakers (hydraulic or cable); Post Drivers; Post Hole Diggers; Road Widening Trenchers; Rollers; Welder Operators.

Class 5 - Backfillers and Tampers; Batch Plants; Bar and Joint Installing Machines; Bull Floats; Burlap and Curing Machines; Cleaning Machine Operator (decontamination included); Clefplanes; Concrete Spreading Machines; Crushers; Deckhands; Drum Fireman (asphalt); Farm-type, Tractor, pulling attachments; Finishing Machines; Forklifts (masonry work only); Form Trenchers; High Pressure Pumps (over 1/2" discharge); Hydro Seeders; Pumps (4" and over discharge), provided it is not part of a de-watering system discharged into a common header; Self-Propelled Power Spreaders; Self-Propelled Sub Graders; Submersible Pump (4" and over discharge), provided it is not part of a dewatering system discharged into a common header; Tire Repairman; Tractors, pulling sheepsfoot rollers or graders; Vibratory Compactors with integral power.

Class 6 - Apprentice/Helpers, Oiler, Signalmen; Barrier Moving Machines (additional duty, paid same rate); Bobcat-type and/or Skid Steer Loader; Bobcat-type and/or Skid Steer Loader with any and all attachments; Brokks with a manufacture's weight less than 3,500 lbs.; Cranes – compact, track or rubber under 4000 lbs. capacity; Geodimeter; Grade Checker; Grinders (all); Inboard/outboard Motor Boat Launches; Light Plant Operators; Planers (all types); Power Boilers (less than 15 lbs. pressure); Power Driven Heaters (oil fired); Power Scrubbers; Power Sweepers; Pumps (under 4 inch discharge); Rod Man; Rotomills; Saw (concrete Vermeer-type); Submersible Pumps (under 4 inch discharge); Vac Alls; Cutting, burning and fabricating on equipment and their attachments.

Class 7 - Master Mechanic

Class 8 - Boom & Jib 200' feet and over

Class 9 - Boom & Jib 300' and over

# Prevailing Wage Rate Skilled Crafts

**Name of Union: Operating Engineers - Building Local 18 - Zone I (A)**

**Change # : LCN01-2020fbLoc18**

**Craft : Operating Engineer Effective Date : 06/01/2020 Last Posted : 05/28/2020**

	BHR		Fringe Benefit Payments					Irrevocable Fund		Total PWR	Overtime Rate	
			H&W	Pension	App Tr.	Vac.	Annuity	Other	LECET (*)			MISC (*)
Classification												
Operator Class 1	\$41.91		\$8.51	\$6.00	\$0.85	\$0.00	\$0.00	\$0.09	\$0.00	\$0.00	\$57.36	\$78.31
Class 2	\$41.76		\$8.51	\$6.00	\$0.85	\$0.00	\$0.00	\$0.09	\$0.00	\$0.00	\$57.21	\$78.09
Class 3	\$40.31		\$8.51	\$6.00	\$0.85	\$0.00	\$0.00	\$0.09	\$0.00	\$0.00	\$55.76	\$75.92
Class 4	\$39.53		\$8.51	\$6.00	\$0.85	\$0.00	\$0.00	\$0.09	\$0.00	\$0.00	\$54.98	\$74.75
Class 5	\$39.21		\$8.51	\$6.00	\$0.85	\$0.00	\$0.00	\$0.09	\$0.00	\$0.00	\$54.66	\$74.26
Class 6	\$32.13		\$8.51	\$6.00	\$0.85	\$0.00	\$0.00	\$0.09	\$0.00	\$0.00	\$47.58	\$63.65
Class 7	\$42.91		\$8.51	\$6.00	\$0.85	\$0.00	\$0.00	\$0.09	\$0.00	\$0.00	\$58.36	\$79.81
Class 8	\$42.91		\$8.51	\$6.00	\$0.85	\$0.00	\$0.00	\$0.09	\$0.00	\$0.00	\$58.36	\$79.81
Class 9	\$43.41		\$8.51	\$6.00	\$0.85	\$0.00	\$0.00	\$0.09	\$0.00	\$0.00	\$58.86	\$80.56
Apprentice	Percent											
1st Year	60.00	\$25.15	\$8.51	\$6.00	\$0.85	\$0.00	\$0.00	\$0.09	\$0.00	\$0.00	\$40.60	\$53.17
2nd Year	70.00	\$29.34	\$8.51	\$6.00	\$0.85	\$0.00	\$0.00	\$0.09	\$0.00	\$0.00	\$44.79	\$59.46
3rd Year	80.00	\$33.53	\$8.51	\$6.00	\$0.85	\$0.00	\$0.00	\$0.09	\$0.00	\$0.00	\$48.98	\$65.74
4th Year	90.00	\$37.72	\$8.51	\$6.00	\$0.85	\$0.00	\$0.00	\$0.09	\$0.00	\$0.00	\$53.17	\$72.03

**Special Calculation Note : Other: Education & Safety**

**Ratio :** **Jurisdiction ( \* denotes special jurisdictional note ):**

For every (3) Operating Engineer Journeymen employed by ASHTABULA, CUYAHOGA, ERIE, GEAUGA, HURON, the company ,there may be employed (1) Registered Apprentice. An apprentice, while employed as part of a crew per Article VIII, paragraph77, will not be subject to the apprenticeship ratios in this collective bargaining agreement.

**Special Jurisdictional Note :**

**Details :**

Note: There will be a 5% increase for the apprentices on top of the percentages listed above provided they are operating mobile equipment. Operating Engineers employed on any piece of equipment requiring a Certified Crane Operator (CCO) certification or employed on cranes involved in pile driving operations shall be paid a premium of one dollar (\$1.00) per hour in addition to the crane rate or any escalated rate that may be in effect.

Class 1 - A-Frames; " Boiler Operators, Compressor Operators, Hydraulic Pumps & Power Pacs when mounted on a crane or regardless of where said equipment is mounted (piggy-back operator)"; Boom Trucks (all types); Cableways; Cherry Pickers; Combination - Concrete Mixers & Towers; Concrete Pumps; Cranes (all types); Cranes- compact: Track or rubber over 4000lbs. capacity; Cranes- self erecting: stationary, track or truck (all configurations); Derricks (all types); Draglines; Dredges (dipper, clam or suction) 3-man crew; Elevating Graders or Euclid Loaders; Floating Equipment; Gradalls; Helicopter Operators, hoisting building materials; Helicopter Winch Operators, hoisting building materials; Hoes (All types); Hoists (with two or more drums in use); Lift Slab or Panel Jack Operators; Locomotives (all types); Maintenance Engineers (Mechanic and/or Welder); Mixers, paving (multiple drum); Mobile Concrete Pumps with booms; Panelboards, (all types on site); Pile Drivers; Power Shovels; Robotics Equipment Operator/Mechanic; Rotary Drills (all), used on caissons work, wells (all types), Geothermal work and sub-structure work; Rough Terrain Forklifts with Winch/Hoist (when used as a crane); Side Booms; Slip Form Pavers; Straddle Carriers (Building Construction on site); Tug Boats; Tunnel Boring Machine (TBM).

Class 2 - Asphalt Pavers; Bulldozers; CMI type Equipment; Endloaders; Horizontal Directional Drill Locator; Horizontal Directional Drill Operator; Instrument Man; Kolman-type Loaders (Dirt Loading); Lead Greasemen; Mucking Machines; Power Graders; Power Scoops; Power Scrapers; Push Cats; Rotomills; Vermeer Type Concrete Saw.

Class 3 - Air Compressors, Pressurizing Shafts or Tunnels; Articulating/Straight bed dumps if assigned by the employer (minus \$4.00 per hour from Class C); All Asphalt Rollers; Fork Lifts; Hoists (with one drum); House Elevators (except those automatic call button controlled); Hydro Excavator (all types C rate) (F rate if a second person is needed) Helper rate; Laser Screeds and like equipment; Man Lifts; Modular Moving and Placement machine (C Rate) (F Rate if second person is needed); Mud Jacks; Portable Hydraulic Gantry (lift system C rate) (F Rate if a second person is needed); Power Boilers (over 15 lbs. pressure); Portable Hydraulic Gantry (lift system C Rate) (F rate if a second person is needed); Pump Operators (installing or operating Well Points or other types of Dewatering Systems); Pressure Grouting; Trenchers (24" and under); Utility Operators.

Class 4 – Brokks with a manufacture's weight of 3,500 lbs. and above; Compressors, on building construction; Conveyors, used for handling building materials; Generators; Gunite Machines; Mixers, more than one bag capacity ; Mixers, one bag capacity (side loader); ;Pavement Breakers (hydraulic or cable); Post Drivers; Post Hole Diggers; Road Widening Trenchers; Rollers; Welder Operators.

Class 5 - Backfillers and Tampers; Batch Plants; Bar and Joint Installing Machines; Bull Floats; Burlap and Curing Machines; Cleaning Machine Operator (decontamination included); Clefplanes; Concrete Spreading Machines; Crushers; Deckhands; Drum Fireman (asphalt); Farm-type, Tractor, pulling attachments; Finishing Machines; Forklifts (masonry work only); Form Trenchers; High Pressure Pumps (over 1/2" discharge); Hydro Seeders; Pumps (4" and over discharge), provided it is not part of a de-watering system discharged into a common header; Self-Propelled Power Spreaders; Self-Propelled Sub Graders; Submersible Pump (4" and over discharge), provided it is not part of a dewatering system discharged into a common header; Tire Repairman; Tractors, pulling sheepsfoot rollers or graders; Vibratory Compactors with integral power.

Class 6 - Apprentice/Helpers, Oiler, Signalmen; Barrier Moving Machines (additional duty, paid same rate); Bobcat-type and/or Skid Steer Loader; Bobcat-type and/or Skid Steer Loader with any and all attachments; Brokks with a manufacture's weight less than 3,500 lbs.; Cranes – compact, track or rubber under 4000 lbs. capacity; Geodimeter; Grade Checker; Grinders (all); Inboard/outboard Motor Boat Launches; Light Plant Operators; Planers (all types); Power Boilers (less than 15 lbs. pressure); Power Driven Heaters (oil fired); Power Scrubbers; Power Sweepers; Pumps (under 4 inch discharge); Rod Man; Rotomills; Saw (concrete Vermeer-type); Submersible Pumps (under 4 inch discharge); Vac Alls; Cutting, burning and fabricating on equipment and their attachments.

Class 7 - Master Mechanic

Class 8 - Boom & Jib 200' feet and over

Class 9 - Boom & Jib 300' and over

# Prevailing Wage Rate Skilled Crafts

Name of Union: Operating Engineers - HevHwy Zone I

Change # : LCN01-2020fbLoc18hevhwyl

Craft : Operating Engineer Effective Date : 05/14/2020 Last Posted : 05/14/2020

	BHR		Fringe Benefit Payments					Irrevocable Fund		Total PWR	Overtime Rate	
			H&W	Pension	App Tr.	Vac.	Annuity	Other	LECET (*)			MISC (*)
Classification												
Operator Class 1	\$39.73		\$8.51	\$6.00	\$0.85	\$0.00	\$0.00	\$0.09	\$0.00	\$0.00	\$55.18	\$75.04
Class 2	\$39.63		\$8.51	\$6.00	\$0.85	\$0.00	\$0.00	\$0.09	\$0.00	\$0.00	\$55.08	\$74.90
Class 3	\$38.59		\$8.51	\$6.00	\$0.85	\$0.00	\$0.00	\$0.09	\$0.00	\$0.00	\$54.04	\$73.34
Class 4	\$37.37		\$8.51	\$6.00	\$0.85	\$0.00	\$0.00	\$0.09	\$0.00	\$0.00	\$52.82	\$71.50
Class 5	\$32.08		\$8.51	\$6.00	\$0.85	\$0.00	\$0.00	\$0.09	\$0.00	\$0.00	\$47.53	\$63.57
Class 6	\$39.98		\$8.51	\$6.00	\$0.85	\$0.00	\$0.00	\$0.09	\$0.00	\$0.00	\$55.43	\$75.42
<b>Apprentice</b>	<b>Percent</b>											
1st Year	50.00	\$19.86	\$8.51	\$6.00	\$0.85	\$0.00	\$0.00	\$0.09	\$0.00	\$0.00	\$35.32	\$45.25
2nd Year	60.00	\$23.84	\$8.51	\$6.00	\$0.85	\$0.00	\$0.00	\$0.09	\$0.00	\$0.00	\$39.29	\$51.21
3rd Year	70.00	\$27.81	\$8.51	\$6.00	\$0.85	\$0.00	\$0.00	\$0.09	\$0.00	\$0.00	\$43.26	\$57.17
4th Year	80.00	\$31.78	\$8.51	\$6.00	\$0.85	\$0.00	\$0.00	\$0.09	\$0.00	\$0.00	\$47.23	\$63.13
<b>Field Mech Trainee</b>												
1st year	49.85	\$19.81	\$8.51	\$6.00	\$0.85	\$0.00	\$0.00	\$0.09	\$0.00	\$0.00	\$35.26	\$45.16
2nd year	59.85	\$23.78	\$8.51	\$6.00	\$0.85	\$0.00	\$0.00	\$0.09	\$0.00	\$0.00	\$39.23	\$51.12
3rd year	69.82	\$27.74	\$8.51	\$6.00	\$0.85	\$0.00	\$0.00	\$0.09	\$0.00	\$0.00	\$43.19	\$57.06
4th year	79.78	\$31.70	\$8.51	\$6.00	\$0.85	\$0.00	\$0.00	\$0.09	\$0.00	\$0.00	\$47.15	\$62.99

**Special Calculation Note :** Other: Education & Safety Fund is \$0.09 per hour.

**Ratio :** **Jurisdiction ( \* denotes special jurisdictional note ):**

For every (3) Operating Engineer Journeymen employed by the company , there may be employed (1) Registered Apprentice or Trainee Engineer through the referral when they are available. An apprentice, while employed as part of a crew per Article VIII paragraph 65, will not be subject the apprenticeship ratios in this collective bargaining agreement.

ASHTABULA, CUYAHOGA, ERIE, GEAUGA, LAKE, LORAIN, MEDINA, PORTAGE, SUMMIT

**Special Jurisdictional Note :**

## Details :

**\*\*Apprentices will receive a 10% increase on top of the percentages listed above provided they are operating mobile equipment. Mechanic Trainees will receive 10% if required to have a CDL.**

Class 1 - Air Compressors on Steel Erection; Asphalt Plant Engineers (Cleveland District Only); Barrier Moving Machine; Boiler Operators, Compressor Operators, or Generators, when mounted on a rig; Boom Trucks (all types); Cableways; Cherry Pickers; Combination- Concrete mixers & Towers; Concrete Pumps; Concrete Plants ( over 4 yd capacity); Cranes (all types); Derricks (all types); Draglines; Elevating Graders or Euclid Loaders; Gradalls; Helicopter Crew (Operator- hoist or winch); Hoes (all types); Hoisting Engines; Hoisting Engines, on shaft or tunnel work; Hydraulic Gantry (lifting system); Locomotives (standard guage); Maintenance Operators (class A); Mixers, paving (single or double drum); Piledriving Machines (all types); Power Shovels, Prentice Loader; Quad 9 (double pusher); Rail Tamper (with automatic lifting and aligning device); Refrigerating Machines (freezer operation); Rotary Drills, on caisson work; Side Booms; Slip Form Pavers; Tower Dericks; Trench Machines; Truck Mounted Concrete Pumps; Tug Boats; Tunnel Machines and /or Mining Machines; Wheel Excavators;Industrial-type tractors; Jet Engine - Dryer (D8 or D9 ) Diesel Tractors Mucking Machines; Multiple Scrapers; Tree Shreddes. Rough Terrain Fork-lift with Winch/Hoist; Compact Cranes,track or rubber over 4,000 pound capacity, self-erecting cranes:stationary,track or truck (all configurations) bucket trench machines (over 24 inches wide).

Class 2 - Asphalt Pavers; Automatic Subgrade Machines, self-propelled (CMI-type); Bobcat-type and /or skid steer loader with hoe attachment greater than 7000 lbs.; Boring Machine Operators (more than 48 inches); Bulldozers; ;Endloaders; Hydro Milling Machine; Kolman-type Loaders (production type-dirt); Lead Greasemen; Maintenance Operators, Class B (Portage and Summit Counties only); Pettibone-Rail Equipment; Power Graders; Power Scrapers; Push Cats; Lighting and Traffic Signal Installation Equipment includes all groups or classifications; Trench Machines (24inch wide and under); Vermeer Type Concrete saw. Material Transfer Equipment (Shuttle buggy) Asphalt All rotomills, grinders and planers of all types. Horizontal Directional Drill (Over 50,000 ft.lbs.thrust and over).

Class 3 - A-Frames; Air Compressors, on tunnel work (low Pressure); All Asphalt Rollers; Asphalt Plant Engineers (Portage and Summit Counties only); Bobcat-type and/or skid steer loader with or without attachments; Power Boilers (15 lbs pressure and over); Highway Drills (all types); Pump Operators (installing or operating well Points); Pumps (4 inch and over discharge); Railroad Tie Inserter/Remover; Rotovator (lime-soil Stabilzer); Switch & Tie Tampers (without lifting and aligning device); Locomotives (narrow gage); Mixers, concrete (more than one bag capacity); Mixers, one bag capacity (side loader); Utilities Operators, (small equipment); Welding Machines and Generators; Material hoist/elevators. Articulating/straight bed end dumps if assigned (minus \$4.00 per hour)

Class 4 - Ballast Re-loacator; Backfillers and Tampers; Batch Plant Operators; Bar and Joint Installing Machines; Boring Machine Operators (48 inch or less); Bull Floats; Burlap and Curing Machines; Concrete Plants (capacity 4 yd and under); Conveyors (highway); Concrete Saws (multiple); Crushers; Deckhands; Farm type tractors, with attachments (highway); Finishing Machines; Hydro Hammers; Hydro Seeders; Pavement Breakers (hydraulic or cable); Plant Mixers; Post Drivers; Post Hole Diggers; Power Brush Burners; Power Form Handling Equipment; Firemen, Floating Equipment (all types); Fork Lifts (highway), except masonry; Form Trenchers; Road Widening Trenchers; Rollers (brick, grade, macadam); Self-Propelled Power Spreaders; Self-Propelled Sub-Graders; Tractors, pulling sheepsfoot rollers or graders; Steam Firemen; Vibratory Compactors, with integral power.

Class 5 - Compressors (portable, Sewer, Heavy and Highway); Generators; Inboard-Outboard Motor Boat Launches; Masonry Fork Lifts; Oilers/Helpers; Power Driven Heaters (oil fired); Power Scrubbers; Power Sweepers; Pumps (under 4 inch discharge); Signalmen; Drum Fireman (in Asphalt Plant); Oil Heaters (Asphalt Plant); Tire Repairmen; VAC/ALLS; Fueling and greasing (Primary Operator with Specialized CDL Endorsement Add \$3.00/hr), compact cranes; track or rubber under 4,000 pounds.

Class 6 - Master Mechanic

# Prevailing Wage Rate Skilled Crafts

Name of Union: Painter Local 505

Change # : LCN01-2020fbLoc505

Craft : Drywall Finisher Effective Date : 07/02/2020 Last Posted : 07/02/2020

	BHR		Fringe Benefit Payments					Irrevocable Fund		Total PWR	Overtime Rate	
			H&W	Pension	App Tr.	Vac.	Annuity	Other	LECET (*)			MISC (*)
Classification												
Painter Drywall Finisher	\$30.19		\$7.17	\$6.08	\$0.40	\$0.00	\$3.47	\$0.00	\$0.00	\$0.00	\$47.31	\$62.41
Apprentice	Percent											
1st 6 months	45.00	\$13.59	\$6.91	\$1.84	\$0.40	\$0.00	\$0.00	\$0.00	\$0.00	\$0.00	\$22.74	\$29.53
2nd 6 months	50.00	\$15.10	\$6.91	\$1.94	\$0.40	\$0.00	\$0.00	\$0.00	\$0.00	\$0.00	\$24.35	\$31.89
3rd 6 months	55.00	\$16.60	\$6.91	\$2.39	\$0.40	\$0.00	\$1.91	\$0.00	\$0.00	\$0.00	\$28.21	\$36.52
4th 6 months	60.00	\$18.11	\$6.91	\$2.49	\$0.40	\$0.00	\$2.08	\$0.00	\$0.00	\$0.00	\$29.99	\$39.05
5th 6 months	65.00	\$19.62	\$6.91	\$2.94	\$0.40	\$0.00	\$2.26	\$0.00	\$0.00	\$0.00	\$32.13	\$41.95
6th 6 months	70.00	\$21.13	\$6.91	\$3.04	\$0.40	\$0.00	\$2.43	\$0.00	\$0.00	\$0.00	\$33.91	\$44.48

**Special Calculation Note :** No special calculation for this classification.

**Ratio :**  
1 Apprentice to 1 Journeyman

**Jurisdiction ( \* denotes special jurisdictional note ):**  
ASHTABULA, CUYAHOGA, GEAUGA, LAKE,  
LORAIN, PORTAGE\*, SUMMIT\*

**Special Jurisdictional Note :** Portage & Summit North of the East-West Turnpike.

**Details :**

# Prevailing Wage Rate Skilled Crafts

Name of Union: Painter Local 639

Change # : LCNO1-2015fbLoc639

Craft : Painter Effective Date : 06/10/2015 Last Posted : 06/10/2015

	BHR	Fringe Benefit Payments						Irrevocable Fund		Total PWR	Overtime Rate
		H&W	Pension	App Tr.	Vac.	Annuity	Other	LECET (*)	MISC (*)		
Classification											
Painter Metal Finisher/Helpers											
Top Helper Class A	\$19.09	\$3.65	\$0.00	\$0.00	\$0.66	\$0.00	\$0.00	\$0.00	\$0.00	\$23.40	\$32.94
Top Helper Class B	\$19.09	\$3.65	\$0.65	\$0.00	\$1.03	\$0.00	\$0.37	\$0.00	\$0.00	\$24.79	\$34.33
Top Helper Class C	\$19.09	\$3.65	\$1.00	\$0.00	\$1.76	\$0.00	\$0.37	\$0.00	\$0.00	\$25.87	\$35.41
Helper Class A	\$14.69	\$3.65	\$0.00	\$0.00	\$0.51	\$0.00	\$0.00	\$0.00	\$0.00	\$18.85	\$26.19
Helper Class B	\$14.69	\$3.65	\$0.65	\$0.00	\$0.79	\$0.00	\$0.28	\$0.00	\$0.00	\$20.06	\$27.40
Helper Class C	\$14.69	\$3.65	\$1.00	\$0.00	\$1.64	\$0.00	\$0.28	\$0.00	\$0.00	\$21.26	\$28.60
New Hire 90 Days	\$11.00	\$3.65	\$0.00	\$0.00	\$0.00	\$0.00	\$0.00	\$0.00	\$0.00	\$14.65	\$20.15

**Special Calculation Note :** Other is Sick and Personal Time

**Ratio :**

**Jurisdiction ( \* denotes special jurisdictional note ) :**

- ADAMS, ALLEN, ASHLAND, ASHTABULA,
- ATHENS, AUGLAIZE, BELMONT, BROWN,
- BUTLER, CARROLL, CHAMPAIGN, CLARK,
- CLERMONT, CLINTON, COLUMBIANA,
- COSHOCTON, CRAWFORD, CUYAHOGA, DARKE,
- DEFIANCE, DELAWARE, ERIE, FAIRFIELD,
- FAYETTE, FRANKLIN, FULTON, GALLIA,
- GEAUGA, GREENE, GUERNSEY, HAMILTON,
- HANCOCK, HARDIN, HARRISON, HENRY,
- HIGHLAND, HOCKING, HOLMES, HURON,
- JACKSON, JEFFERSON, KNOX, LAKE,
- LAWRENCE, LICKING, LOGAN, LORAIN, LUCAS,
- MADISON, MAHONING, MARION, MEDINA,
- MEIGS, MERCER, MIAMI, MONROE,
- MONTGOMERY, MORGAN, MORROW,
- MUSKINGUM, NOBLE, OTTAWA, PAULDING,
- PERRY, PICKAWAY, PIKE, PORTAGE, PREBLE,
- PUTNAM, RICHLAND, ROSS, SANDUSKY,

SCIOTO, SENECA, SHELBY, STARK, SUMMIT,  
TRUMBULL, TUSCARAWAS, UNION, VAN WERT,  
VINTON, WARREN, WASHINGTON, WAYNE,  
WILLIAMS, WOOD, WYANDOT

### **Special Jurisdictional Note :**

#### **Details :**

Top Helper: Shall perform the responsibilities of a Helper and be responsible for the setup, break down, safety and quality of the company's product.

Helper : Shall be responsible for performing tasks in refinishing, compliance with safety procedures, setting up and breaking down job sites, scaffolding and swing stages and preparing surfaces for refinishing including but not limited to, masking and stripping and cleaning, oxidizing, polishing and scratch removal on various surfaces

Class A Workers: Less than 1 Year of Service.

Class B Workers: More than 1 and less than 8 Years of Service.

Class C Workers: More than 8 Years of Service.

Metal Polisher Scope of Work: Polishing, buffing, stripping, coloring, lacquering, spraying, cleaning and maintenance of ornamental and architectural metals, iron, bronze, nickel, aluminum and stainless steel and in mental specialty work, various stone finishes, stone specialty work and any other work pertaining to the finishing of metal, stones, woods, and any window washing/cleaning done in conjunction with this work, using chemicals, solvents, coatings and hand applied lacquer thinner, removing scratches from mirror finished metals, burnishing of bronze, statuary finishes on exterior and interior surfaces and the use of all tools required to perform such work, including but not limited to polishes, spray equipment and scaffolding.

Swing State Rate: All work on scaffold 4 sections or higher, including any boom lifts and swing stage scaffolds including the rigging and derigging of hanging/suspended swing stage systems and rappelling/bolson chair work, ADD \$1.50 per hour.

# Prevailing Wage Rate Skilled Crafts

Name of Union: Painter Local 639 Zone 2 Sign

Change # : LCN01-2016fbLoc639

Craft : Painter Effective Date : 08/03/2016 Last Posted : 08/03/2016

	BHR	Fringe Benefit Payments						Irrevocable Fund		Total PWR	Overtime Rate
		H&W	Pension	App Tr.	Vac.	Annuity	Other	LECET (*)	MISC (*)		
Classification											
Painter Sign Journeyman Tech/Team Leader Class A	\$21.25	\$1.33	\$0.14	\$0.00	\$0.00	\$0.00	\$0.57	\$0.00	\$0.00	\$23.29	\$33.92
Painter Sign Journeyman Tech/Team Leader Class B	\$21.25	\$1.33	\$0.14	\$0.00	\$0.41	\$0.00	\$0.57	\$0.00	\$0.00	\$23.70	\$34.32
Painter Sign Journeyman Tech/Team Leader Class C	\$21.25	\$1.33	\$0.14	\$0.00	\$0.82	\$0.00	\$0.57	\$0.00	\$0.00	\$24.11	\$34.74
Painter Sign Journeyman Tech/Team Leader Class D	\$21.25	\$1.33	\$0.14	\$0.00	\$1.23	\$0.00	\$0.57	\$0.00	\$0.00	\$24.52	\$35.14
Sign Journeyman Class A	\$20.98	\$1.33	\$0.14	\$0.00	\$0.00	\$0.00	\$0.56	\$0.00	\$0.00	\$23.01	\$33.50
Sign Journeyman Class B	\$20.98	\$1.33	\$0.14	\$0.00	\$0.40	\$0.00	\$0.56	\$0.00	\$0.00	\$23.41	\$33.90
Sign Journeyman Class C	\$20.98	\$1.33	\$0.14	\$0.00	\$0.81	\$0.00	\$0.56	\$0.00	\$0.00	\$23.82	\$34.31
Sign Journeyman Class D	\$20.98	\$1.33	\$0.14	\$0.00	\$1.21	\$0.00	\$0.56	\$0.00	\$0.00	\$24.22	\$34.71
Tech Sign Fabrication/ Erector Class A	\$15.90	\$1.33	\$0.14	\$0.00	\$0.00	\$0.00	\$0.43	\$0.00	\$0.00	\$17.80	\$25.75
Tech Sign	\$15.90	\$1.33	\$0.14	\$0.00	\$0.31	\$0.00	\$0.43	\$0.00	\$0.00	\$18.11	\$26.06

Fabrication/ Erector Class B											
Tech Sign Fabrication/ Erector Class C	\$15.90	\$1.33	\$0.14	\$0.00	\$0.61	\$0.00	\$0.43	\$0.00	\$0.00	\$18.41	\$26.36
Tech Sign Fabrication/ Erector Class D	\$15.90	\$1.33	\$0.14	\$0.00	\$0.92	\$0.00	\$0.43	\$0.00	\$0.00	\$18.72	\$26.67

**Special Calculation Note :** Other is for paid holidays.

**Ratio :**

**Jurisdiction ( \* denotes special jurisdictional note ) :**

ADAMS, ALLEN, AUGLAIZE, BROWN, BUTLER, CARROLL, CHAMPAIGN, CLARK, CLERMONT, CLINTON, COLUMBIANA, COSHOCTON, CRAWFORD, DARKE, DEFIANCE, DELAWARE, ERIE, FAIRFIELD, FAYETTE, FRANKLIN, FULTON, GREENE, HAMILTON, HANCOCK, HARDIN, HENRY, HIGHLAND, HOLMES, HURON, JACKSON, KNOX, LICKING, LOGAN, LORAIN, LUCAS, MADISON, MAHONING, MARION, MERCER, MIAMI, MONTGOMERY, MORROW, MUSKINGUM, OTTAWA, PAULDING, PERRY, PICKAWAY, PIKE, PREBLE, PUTNAM, ROSS, SANDUSKY, SCIOTO, SENECA, SHELBY, STARK, TRUMBULL, TUSCARAWAS, UNION, VAN WERT, WARREN, WAYNE, WILLIAMS, WOOD, WYANDOT

**Special Jurisdictional Note :**

**Details :**

Class A: less than 1 year.

Class B: 1-3 years.

Class C: 3-10 years.

Class D: More than 10 years.

# Prevailing Wage Rate Skilled Crafts

Name of Union: Painter Local 707

Change # : LCN01-2020fbLoc707

Craft : Painter Effective Date : 07/02/2020 Last Posted : 07/02/2020

	BHR		Fringe Benefit Payments					Irrevocable Fund		Total PWR	Overtime Rate	
			H&W	Pension	App Tr.	Vac.	Annuity	Other	LECET (*)			MISC (*)
<b>Classification</b>												
Painter Brush Roll	\$28.96		\$7.17	\$5.08	\$0.40	\$0.00	\$4.15	\$0.00	\$0.00	\$0.00	\$45.76	\$60.24
Paperhanger	\$28.96		\$7.17	\$5.08	\$0.40	\$0.00	\$4.15	\$0.00	\$0.00	\$0.00	\$45.76	\$60.24
Sandblasting & Buffing	\$29.36		\$7.17	\$5.08	\$0.40	\$0.00	\$4.15	\$0.00	\$0.00	\$0.00	\$46.16	\$60.84
Spray Painting	\$29.66		\$7.17	\$5.08	\$0.40	\$0.00	\$4.15	\$0.00	\$0.00	\$0.00	\$46.46	\$61.29
REPAINT Brush Roll & Paperhanger	\$27.46		\$7.17	\$5.08	\$0.40	\$0.00	\$4.15	\$0.00	\$0.00	\$0.00	\$44.26	\$57.99
REPAINT Sandblasting & Buffing	\$27.86		\$7.17	\$5.08	\$0.40	\$0.00	\$4.15	\$0.00	\$0.00	\$0.00	\$44.66	\$58.59
REPAINT Spray Painting	\$28.16		\$7.17	\$5.08	\$0.40	\$0.00	\$4.15	\$0.00	\$0.00	\$0.00	\$44.96	\$59.04
<b>Apprentice - Painter</b>												
	<b>Percent</b>											
1st 6 months	45.00	\$13.03	\$7.17	\$1.59	\$0.40	\$0.00	\$0.00	\$0.00	\$0.00	\$0.00	\$22.19	\$28.71
2nd 6 months	50.00	\$14.48	\$7.17	\$1.64	\$0.40	\$0.00	\$0.00	\$0.00	\$0.00	\$0.00	\$23.69	\$30.93
3rd 6 months	55.00	\$15.93	\$7.17	\$2.13	\$0.40	\$0.00	\$2.28	\$0.00	\$0.00	\$0.00	\$27.91	\$35.87
4th 6 months	60.00	\$17.38	\$7.17	\$2.17	\$0.40	\$0.00	\$2.49	\$0.00	\$0.00	\$0.00	\$29.61	\$38.29
5th 6 months	65.00	\$18.82	\$7.17	\$2.52	\$0.40	\$0.00	\$2.70	\$0.00	\$0.00	\$0.00	\$31.61	\$41.03
6th 6 months	70.00	\$20.27	\$7.17	\$2.56	\$0.40	\$0.00	\$2.91	\$0.00	\$0.00	\$0.00	\$33.31	\$43.45
7th 6 months	75.00	\$21.72	\$7.17	\$3.31	\$0.40	\$0.00	\$3.11	\$0.00	\$0.00	\$0.00	\$35.71	\$46.57
8th 6 months	80.00	\$23.17	\$7.17	\$3.35	\$0.40	\$0.00	\$3.32	\$0.00	\$0.00	\$0.00	\$37.41	\$48.99

**Special Calculation Note :** Apprentice pay based on percentage of above appropriate classification.

**Ratio :**

1 Apprentice to 1 Journeyman

**Jurisdiction ( \* denotes special jurisdictional note ):**

ASHTABULA, CUYAHOGA, GEAUGA, LAKE,

**Special Jurisdictional Note :** Portage & Summit North of the East-West Turnpike.

**Details :**

Application of Catalytic materials under class 3 hazardous per MSDS - .65 per hour above the Job Classification basic hourly rate.

Application of Catalytic materials under class 4 hazardous per MSDS - 1.00 per hour above the Job Classification basic hourly rate.

# Prevailing Wage Rate Skilled Crafts

Name of Union: Painter Local 707 HvyHwy

Change # : LCN01-2020fbLoc707Ind

Craft : Painter Effective Date : 07/02/2020 Last Posted : 07/02/2020

	BHR		Fringe Benefit Payments					Irrevocable Fund		Total PWR	Overtime Rate	
			H&W	Pension	App Tr.	Vac.	Annuity	Other	LECET (*)			MISC (*)
<b>Classification</b>												
Painter Bridge Class 1 Bridge Blaster	\$35.22		\$7.17	\$5.08	\$0.40	\$0.00	\$4.15	\$0.00	\$0.00	\$0.00	\$52.02	\$69.63
Class 2 Bridge Painter, Rigger Containment Builder, Spot Blaster	\$32.22		\$7.17	\$5.08	\$0.40	\$0.00	\$4.15	\$0.00	\$0.00	\$0.00	\$49.02	\$65.13
Class 3 Equipment Operator/Field Mechanic, Grit Reclamation, Paint Mixer, Traffic Control Boat Person, Driver (0-5 Years Exp.)	\$25.22		\$7.17	\$5.08	\$0.40	\$0.00	\$4.15	\$0.00	\$0.00	\$0.00	\$42.02	\$54.63
Class 3 Equipment Operator/Field Mechanic, Grit Reclamation, Paint Mixer, Traffic Control Boat Person, Driver (5 Plus Years Exp.)	\$28.22		\$7.17	\$5.08	\$0.40	\$0.00	\$4.15	\$0.00	\$0.00	\$0.00	\$45.02	\$59.13
Class 4 Concrete Sealing, Concrete Blasting/Power Washing/Etc	\$24.22		\$7.17	\$5.08	\$0.40	\$0.00	\$4.15	\$0.00	\$0.00	\$0.00	\$41.02	\$53.13
Class 5 Quality Control. Quality Assurance, Traffic Safety, Competent Person	\$28.22		\$7.17	\$5.08	\$0.40	\$0.00	\$4.15	\$0.00	\$0.00	\$0.00	\$45.02	\$59.13
<b>Apprentice - Painter</b>	<b>Percent</b>											
1st 6 months	45.00	\$15.85	\$7.17	\$1.59	\$0.40	\$0.00	\$0.00	\$0.00	\$0.00	\$0.00	\$25.01	\$32.93
2nd 6 months	50.00	\$17.61	\$7.17	\$1.64	\$0.40	\$0.00	\$0.00	\$0.00	\$0.00	\$0.00	\$26.82	\$35.63

3rd 6 months	55.00	\$19.37	\$7.17	\$2.13	\$0.40	\$0.00	\$2.28	\$0.00	\$0.00	\$0.00	\$31.35	\$41.04
4th 6 months	60.00	\$21.13	\$7.17	\$2.17	\$0.40	\$0.00	\$2.49	\$0.00	\$0.00	\$0.00	\$33.36	\$43.93
5th 6 months	65.00	\$22.89	\$7.17	\$2.52	\$0.40	\$0.00	\$2.70	\$0.00	\$0.00	\$0.00	\$35.68	\$47.13
6th 6 months	70.00	\$24.65	\$7.17	\$2.56	\$0.40	\$0.00	\$2.91	\$0.00	\$0.00	\$0.00	\$37.69	\$50.02
7th 6 months	75.00	\$26.41	\$7.17	\$3.31	\$0.40	\$0.00	\$3.11	\$0.00	\$0.00	\$0.00	\$40.41	\$53.61
8th 6 months	80.00	\$28.18	\$7.17	\$3.35	\$0.40	\$0.00	\$3.32	\$0.00	\$0.00	\$0.00	\$42.42	\$56.50

**Special Calculation Note :** Apprentice pay based on percentage of above appropriate classification.

**Ratio :** 1 Apprentice to 1 Journeyman

**Jurisdiction ( \* denotes special jurisdictional note ) :**  
 ASHTABULA, CUYAHOGA, GEAUGA, LAKE,  
 LORAIN, PORTAGE\*, SUMMIT\*

**Special Jurisdictional Note :** Portage & Summit North of the East-West Turnpike.

**Details :**

Painter Bridge Class 2 is Defined as; Bridge Painter, Rigger, Containment Builder

Application of Catalytic materials under class 3 hazardous per MSDS - .65 per hour above the Job Classification basic hourly rate.

Application of Catalytic materials under class 4 hazardous per MSDS - 1.00 per hour above the Job Classification basic hourly rate.

\* Concrete Sealing: on highway work, scaling of concrete surfaces, the treating and sealing of bridge decks, the painting and staining of concrete, including the abutments, barricades, noise barriers, lane dividers, etc.

# Prevailing Wage Rate Skilled Crafts

Name of Union: Plasterer Local 526

**Change # : LCR01-2021fbLoc80**

**Craft : Plaster Effective Date : 05/01/2021 Last Posted : 04/28/2021**

	BHR	Fringe Benefit Payments						Irrevocable Fund		Total PWR	Overtime Rate
		H&W	Pension	App Tr.	Vac.	Annuity	Other	LECET (*)	MISC (*)		
<b>Classification</b>											
Plasterer	\$30.00	\$7.75	\$6.45	\$0.50	\$0.00	\$5.58	\$0.18	\$0.00	\$0.00	\$50.46	\$65.46

**Special Calculation Note :** Other is for Substance abuse and training.

**Ratio :**

1 Journeymen to 1 Apprentice  
3 Journeymen to 1 Apprentice.

**Jurisdiction ( \* denotes special jurisdictional note ) :**

ASHTABULA, CUYAHOGA, GEAUGA, LAKE, LORAIN

**Special Jurisdictional Note :**

**Details :**

# Prevailing Wage Rate Skilled Crafts

Name of Union: Pipefitter Local 120

Change # : LCNO1-2020fbLoc120

Craft : Sprinkler Fitter Effective Date : 05/14/2020 Last Posted : 05/14/2020

	BHR		Fringe Benefit Payments					Irrevocable Fund		Total PWR	Overtime Rate	
			H&W	Pension	App Tr.	Vac.	Annuity	Other	LECET (*)			MISC (*)
<b>Classification</b>												
Sprinkler Fitter	\$40.22		\$11.90	\$10.70	\$1.02	\$0.00	\$3.00	\$0.30	\$0.00	\$0.00	\$67.14	\$87.25
<b>Apprentice</b>	<b>Percent</b>											
1st year	49.18	\$19.78	\$5.35	\$0.00	\$1.02	\$0.00	\$0.00	\$0.00	\$0.00	\$0.00	\$26.15	\$36.04
2nd year	51.34	\$20.65	\$11.30	\$6.10	\$1.02	\$0.00	\$0.00	\$0.30	\$0.00	\$0.00	\$39.37	\$49.69
3rd year	59.57	\$23.96	\$11.30	\$6.10	\$1.02	\$0.00	\$0.00	\$0.30	\$0.00	\$0.00	\$42.68	\$54.66
4th year	71.06	\$28.58	\$11.30	\$6.10	\$1.02	\$0.00	\$0.00	\$0.30	\$0.00	\$0.00	\$47.30	\$61.59
5th year	79.29	\$31.89	\$11.30	\$6.10	\$1.02	\$0.00	\$0.00	\$0.30	\$0.00	\$0.00	\$50.61	\$66.56

**Special Calculation Note :** OTHER IS :SUPPLEMENTAL UNEMPLOYMENT BENEFITS

**Ratio :**

- 1 Journeymen to 1 Apprentice per project
- 2 - 4 Journeymen to 2 Apprentices
- 5 - 7 Journeymen to 3 Apprentices

3 Journeymen to 1 Apprentice on jobs with 9 or more journeymen

**Jurisdiction ( \* denotes special jurisdictional note ):**

CUYAHOGA, GEAUGA, LAKE, LORAIN

**Special Jurisdictional Note :**

**Details :**

Sprinklerfitter duties shall include: installation, dismantling, maintenance, repairs, adjustments and corrections of all fire protection and extinguishing systems; consist of handling and installing of all piping and appurtenances pertaining to sprinkler equipment including both overhead and underground water mains, fire hydrants and hydrants mains, stand pipes, hose connections, tank heaters, air lines, thermal systems and their connections; all operating and actuating lines and devices and their protective covering; all fire stopping of sprinkler piping systems; all tanks, pumps and city connections; fire protection systems using emulsify, spray, water fog, CO2 gas, foam and other fire control agents, settling of all fire pumps and tank filling pumps, air compressors and their connections; all work related to sprinkler inspections (included but not limited to: adjustments, maintenance, repair, testing, etc.)

# Prevailing Wage Rate Skilled Crafts

Name of Union: **Plumber Pipefitter Local 42**

**Change # : LCR01-2020fbLoc42**

**Craft : Plumber/Pipefitter Effective Date : 07/09/2020 Last Posted : 07/09/2020**

	BHR		Fringe Benefit Payments					Irrevocable Fund		Total PWR	Overtime Rate	
			H&W	Pension	App Tr.	Vac.	Annuity	Other	LECET (*)			MISC (*)
Classification												
Plumber Pipefitter	\$32.82		\$12.22	\$11.35	\$1.10	\$0.00	\$0.00	\$0.00	\$0.00	\$0.00	\$57.49	\$73.90
Plumber Pipefitter Heavy Industrial	\$34.82		\$12.22	\$11.35	\$1.10	\$0.00	\$0.00	\$0.00	\$0.00	\$0.00	\$59.49	\$76.90
Apprentice Heavy Industrial												
1st yr-1st half	\$13.93		\$12.22	\$0.00	\$1.10	\$0.00	\$0.00	\$0.00	\$0.00	\$0.00	\$27.25	\$34.22
1st yr-2nd half	\$15.67		\$12.22	\$0.00	\$1.10	\$0.00	\$0.00	\$0.00	\$0.00	\$0.00	\$28.99	\$36.83
2nd yr-1st half	\$17.41		\$12.22	\$11.35	\$1.10	\$0.00	\$0.00	\$0.00	\$0.00	\$0.00	\$42.08	\$50.79
2nd yr-2nd half	\$19.15		\$12.22	\$11.35	\$1.10	\$0.00	\$0.00	\$0.00	\$0.00	\$0.00	\$43.82	\$53.40
3rd yr-1st half	\$20.89		\$12.22	\$11.35	\$1.10	\$0.00	\$0.00	\$0.00	\$0.00	\$0.00	\$45.56	\$56.01
3rd yr-2nd half	\$22.63		\$12.22	\$11.35	\$1.10	\$0.00	\$0.00	\$0.00	\$0.00	\$0.00	\$47.30	\$58.62
4th yr-1st half	\$24.37		\$12.22	\$11.35	\$1.10	\$0.00	\$0.00	\$0.00	\$0.00	\$0.00	\$49.04	\$61.23
4th yr-2nd half	\$26.12		\$12.22	\$11.35	\$1.10	\$0.00	\$0.00	\$0.00	\$0.00	\$0.00	\$50.79	\$63.85
5th yr-1st half	\$27.86		\$12.22	\$11.35	\$1.10	\$0.00	\$0.00	\$0.00	\$0.00	\$0.00	\$52.53	\$66.46
5th yr-2nd half	\$29.60		\$12.22	\$11.35	\$1.10	\$0.00	\$0.00	\$0.00	\$0.00	\$0.00	\$54.27	\$69.07
<b>Apprentice</b>	<b>Percent</b>											
1st Year 1st Half	40.00	\$13.13	\$12.22	\$0.00	\$1.10	\$0.00	\$0.00	\$0.00	\$0.00	\$0.00	\$26.45	\$33.01
1st Year 2nd Half	45.00	\$14.77	\$12.22	\$0.00	\$1.10	\$0.00	\$0.00	\$0.00	\$0.00	\$0.00	\$28.09	\$35.47

2nd Year 1st Half	50.00	\$16.41	\$12.22	\$11.35	\$1.10	\$0.00	\$0.00	\$0.00	\$0.00	\$0.00	\$41.08	\$49.29
2nd Year 2nd Half	55.00	\$18.05	\$12.22	\$11.35	\$1.10	\$0.00	\$0.00	\$0.00	\$0.00	\$0.00	\$42.72	\$51.75
3rd Year 1st Half	60.00	\$19.69	\$12.22	\$11.35	\$1.10	\$0.00	\$0.00	\$0.00	\$0.00	\$0.00	\$44.36	\$54.21
3rd Year 2nd Half	65.00	\$21.33	\$12.22	\$11.35	\$1.10	\$0.00	\$0.00	\$0.00	\$0.00	\$0.00	\$46.00	\$56.67
4th Year 1st Half	70.00	\$22.97	\$12.22	\$11.35	\$1.10	\$0.00	\$0.00	\$0.00	\$0.00	\$0.00	\$47.64	\$59.13
4th Year 2nd Half	75.00	\$24.62	\$12.22	\$11.35	\$1.10	\$0.00	\$0.00	\$0.00	\$0.00	\$0.00	\$49.29	\$61.59
5th Year 1st Half	80.00	\$26.26	\$12.22	\$11.35	\$1.10	\$0.00	\$0.00	\$0.00	\$0.00	\$0.00	\$50.93	\$64.05
5th Year 2nd Half	85.00	\$27.90	\$12.22	\$11.35	\$1.10	\$0.00	\$0.00	\$0.00	\$0.00	\$0.00	\$52.57	\$66.52

**Special Calculation Note :** No special calculations for this skilled craft wage rate are required at this time.

**Ratio :**

- 1 Journeyman to 1 Apprentice
- 2 Journeymen to 2 Apprentice
- 3 Journeymen to 3 Apprentice
- 4-6 Journeymen to 4 Apprentice

**Jurisdiction ( \* denotes special jurisdictional note ):**

ASHLAND, CRAWFORD, ERIE, HURON, KNOX,  
LORAIN, MORROW, RICHLAND, WYANDOT

Water Treatment Work described below is a ratio of:

- 1 Journeyman to 1 Apprentice

**Special Jurisdictional Note :**

**Details :**

Includes but not limited to : all water services from main to building including water meters and water meter foundations, all lawn sprinkler work including piping, fittings, and lawn sprinkler heads, all power plant piping of every description. All fire extinguishing systems and piping whether by water, steam, gas, or chemical, fire alarm piping and control tubing.

On Water Treatment Plants, waste water treatment plants, prefabricated water treatment plants, lift stations, elevated water tanks, meter vaults, underground work on site at treatment, water mains and fire protection external mains, all construction work on public utilities obtained by employer other than plumbing and heating.

On all construction projects wherein the work involves sanitary sewers, storm sewers and water lines (site work) performed outside the structure of the building.

# Prevailing Wage Rate Skilled Crafts

Name of Union: Sheet Metal Local 33 (Vermilion)

Change # : LCN03-2020fbVer33

Craft : Sheet Metal Worker Effective Date : 09/23/2020 Last Posted : 09/23/2020

	BHR		Fringe Benefit Payments					Irrevocable Fund		Total PWR	Overtime Rate	
			H&W	Pension	App Tr.	Vac.	Annuity	Other	LECET (*)			MISC (*)
<b>Classification</b>												
Sheet Metal Worker	\$31.63		\$8.60	\$11.93	\$0.90	\$0.00	\$4.00	\$0.00	\$0.00	\$0.00	\$57.06	\$72.87
Industrial Door	\$23.08		\$7.38	\$5.33	\$0.17	\$0.00	\$1.87	\$0.00	\$0.00	\$0.00	\$37.83	\$49.37
Apprentice Helper Trainee												
1st 60 Days Probationary Period	\$11.63		\$0.00	\$0.00	\$0.00	\$0.00	\$0.00	\$0.00	\$0.00	\$0.00	\$11.63	\$17.44
61 days -12 Months	\$12.97		\$7.38	\$1.84	\$0.17	\$0.00	\$1.25	\$0.00	\$0.00	\$0.00	\$23.61	\$30.10
2nd Year	\$15.20		\$7.38	\$1.84	\$0.17	\$0.00	\$1.40	\$0.00	\$0.00	\$0.00	\$25.99	\$33.59
3rd Year	\$16.32		\$7.38	\$1.84	\$0.17	\$0.00	\$1.48	\$0.00	\$0.00	\$0.00	\$27.19	\$35.35
4th Year	\$17.89		\$7.38	\$1.84	\$0.17	\$0.00	\$1.58	\$0.00	\$0.00	\$0.00	\$28.86	\$37.81
5th Year	\$19.23		\$7.38	\$1.84	\$0.17	\$0.00	\$1.67	\$0.00	\$0.00	\$0.00	\$30.29	\$39.91
<b>Apprentice</b>	<b>Percent</b>											
1st Year	45.00	\$14.23	\$8.60	\$5.37	\$0.18	\$0.00	\$0.00	\$0.00	\$0.00	\$0.00	\$28.38	\$35.50
2nd Year	50.00	\$15.82	\$8.60	\$5.97	\$0.90	\$0.00	\$2.00	\$0.00	\$0.00	\$0.00	\$33.28	\$41.19
3rd Year	60.00	\$18.98	\$8.60	\$7.16	\$0.90	\$0.00	\$2.00	\$0.00	\$0.00	\$0.00	\$37.64	\$47.13
4th Year	70.00	\$22.14	\$8.60	\$8.35	\$0.90	\$0.00	\$2.00	\$0.00	\$0.00	\$0.00	\$41.99	\$53.06
5th Year	80.00	\$25.30	\$8.60	\$9.54	\$0.90	\$0.00	\$2.00	\$0.00	\$0.00	\$0.00	\$46.34	\$59.00

**Special Calculation Note :** No special calculations for this skilled craft wage rate are required at this time.

**Ratio :**

- 1 Journeyman to 1 Apprentice
- 2 Journeymen to 1 Apprentice
- 3 Journeymen to 2 Apprentice
- 5 Journeymen to 3 Apprentice
- 7 Journeymen to 4 Apprentice
- 9 Journeymen to 5 Apprentice
- 11 Journeymen to 6 Apprentices

**Jurisdiction ( \* denotes special jurisdictional note ):**

ERIE, HURON, LORAIN, SANDUSKY

14 Journeymen to 7 Apprentices  
17 Journeymen to 8 Apprentices  
19 Journeymen to 8 Apprentices  
Thereafter  
3 Journeymen to 1 Apprentice Ratio

**Special Jurisdictional Note :**

**Details :**

Industrial Door- Installation and service of overhead doors roll up doors, docks and dock leveling equipment.

# Prevailing Wage Rate

## Skilled Crafts

Name of Union: Truck Driver Bldg & HevHwy Class 1  
Locals 20,40,92,92b,100,175,284,438,377,637,908,957

Change # : OCRO1-2019fbBldgHevHwy

Craft : Truck Driver Effective Date : 09/11/2019 Last Posted : 09/11/2019

	BHR		Fringe Benefit Payments					Irrevocable Fund		Total PWR	Overtime Rate	
			H&W	Pension	App Tr.	Vac.	Annuity	Other	LECET (*)	MISC (*)		
Classification												
Truck Driver CLASS 1 4 wheel service, dump, and batch trucks, Oil Distributor - Asphalt Distributor-Tandems	\$28.04		\$7.00	\$7.90	\$0.20	\$0.00	\$0.00	\$0.00	\$0.00	\$0.00	\$43.14	\$57.16
Apprentice	Percent											
First 6 months	80.00	\$22.43	\$7.00	\$7.90	\$0.20	\$0.00	\$0.00	\$0.00	\$0.00	\$0.00	\$37.53	\$48.75
7-12 months	85.00	\$23.83	\$7.00	\$7.90	\$0.20	\$0.00	\$0.00	\$0.00	\$0.00	\$0.00	\$38.93	\$50.85
13-18 months	90.00	\$25.24	\$7.00	\$7.90	\$0.20	\$0.00	\$0.00	\$0.00	\$0.00	\$0.00	\$40.34	\$52.95
19-24 months	95.00	\$26.64	\$7.00	\$7.90	\$0.20	\$0.00	\$0.00	\$0.00	\$0.00	\$0.00	\$41.74	\$55.06
25-30 months	100.00	\$28.04	\$7.00	\$7.90	\$0.20	\$0.00	\$0.00	\$0.00	\$0.00	\$0.00	\$43.14	\$57.16

**Special Calculation Note :** No special calculations for this skilled craft wage rate are required at this time.

### Ratio :

3 Journeymen to 1 Apprentice

### Jurisdiction ( \* denotes special jurisdictional note ) :

ADAMS, ALLEN, ASHLAND, ASHTABULA, ATHENS, AUGLAIZE, BELMONT, BROWN, BUTLER, CARROLL, CHAMPAIGN, CLARK, CLERMONT, CLINTON, COLUMBIANA, COSHOCTON, CRAWFORD, DARKE, DEFIANCE, DELAWARE, ERIE, FAIRFIELD, FAYETTE, FRANKLIN, FULTON, GALLIA, GREENE,

GUERNSEY, HAMILTON, HANCOCK, HARDIN,  
HARRISON, HENRY, HIGHLAND, HOCKING,  
HOLMES, HURON, JACKSON, JEFFERSON,  
KNOX, LAWRENCE, LICKING, LOGAN, LORAIN,  
LUCAS, MADISON, MAHONING, MARION,  
MEDINA, MEIGS, MERCER, MIAMI, MONROE,  
MONTGOMERY, MORGAN, MORROW,  
MUSKINGUM, NOBLE, OTTAWA, PAULDING,  
PERRY, PICKAWAY, PIKE, PORTAGE, PREBLE,  
PUTNAM, RICHLAND, ROSS, SANDUSKY,  
SCIOTO, SENECA, SHELBY, STARK, SUMMIT,  
TRUMBULL, TUSCARAWAS, UNION, VAN WERT,  
VINTON, WARREN, WASHINGTON, WAYNE,  
WILLIAMS, WOOD, WYANDOT

**Special Jurisdictional Note :**

**Details :**

\*\* Asphalt - Oil spray bar man when operating from cab shall receive \$0.20 cents per hour above their Basic Hourly Rate.

# Prevailing Wage Rate

## Skilled Crafts

Name of Union: Truck Driver Bldg & HevHwy Class 2  
Locals 20,40,92,92b,100,175,284,438,377,637,908,957

Change # : LCRO1-2019-fbBldgHevHwy

Craft : Truck Driver Effective Date : 10/16/2019 Last Posted : 10/16/2019

	BHR		Fringe Benefit Payments						Irrevocable Fund		Total PWR	Overtime Rate
			H&W	Pension	App Tr.	Vac.	Annuity	Other	LECET (*)	MISC (*)		
<b>Classification</b>												
Truck Driver CLASS 2 Tractor Trailer-Semi Tractor Trucks-Pole Trailers-Ready Mix Trucks-Fuel Trucks- Asphalt-Oil Spray bar men- 5 Axle & Over - Belly Dumps-End Dumps-Articulated Dump Trucks- Low boys-Heavy duty Equipment(irrespective of load carried) when used exclusively for transportation-Truck Mechanics (when needed)	\$28.46		\$7.00	\$7.90	\$0.20	\$0.00	\$0.00	\$0.00	\$0.00	\$0.00	\$43.56	\$57.79
<b>Apprentice</b>	<b>Percent</b>											
First 6 months	80.00	\$22.77	\$7.00	\$7.90	\$0.20	\$0.00	\$0.00	\$0.00	\$0.00	\$0.00	\$37.87	\$49.25
7-12 months	85.00	\$24.19	\$7.00	\$7.90	\$0.20	\$0.00	\$0.00	\$0.00	\$0.00	\$0.00	\$39.29	\$51.39
13-18 months	90.00	\$25.61	\$7.00	\$7.90	\$0.20	\$0.00	\$0.00	\$0.00	\$0.00	\$0.00	\$40.71	\$53.52
19-24 months	95.00	\$27.04	\$7.00	\$7.90	\$0.20	\$0.00	\$0.00	\$0.00	\$0.00	\$0.00	\$42.14	\$55.66
25-30 months	100.00	\$28.46	\$7.00	\$7.90	\$0.20	\$0.00	\$0.00	\$0.00	\$0.00	\$0.00	\$43.56	\$57.79

**Special Calculation Note :** No special calculations for this skilled craft wage rate are required at this time.

### Ratio :

3 Journeymen to 1 Apprentice

### Jurisdiction ( \* denotes special jurisdictional note ) :

ADAMS, ALLEN, ASHLAND, ASHTABULA,  
ATHENS, AUGLAIZE, BELMONT, BROWN,  
BUTLER, CARROLL, CHAMPAIGN, CLARK,  
CLERMONT, CLINTON, COLUMBIANA,  
COSHOCTON, CRAWFORD, DARKE, DEFIANCE,  
DELAWARE, ERIE, FAIRFIELD, FAYETTE,  
FRANKLIN, FULTON, GALLIA, GREENE,

GUERNSEY, HAMILTON, HANCOCK, HARDIN,  
HARRISON, HENRY, HIGHLAND, HOCKING,  
HOLMES, HURON, JACKSON, JEFFERSON,  
KNOX, LAWRENCE, LICKING, LOGAN, LORAIN,  
LUCAS, MADISON, MAHONING, MARION,  
MEDINA, MEIGS, MERCER, MIAMI, MONROE,  
MONTGOMERY, MORGAN, MORROW,  
MUSKINGUM, NOBLE, OTTAWA, PAULDING,  
PERRY, PICKAWAY, PIKE, PORTAGE, PREBLE,  
PUTNAM, RICHLAND, ROSS, SANDUSKY,  
SCIOTO, SENECA, SHELBY, STARK, SUMMIT,  
TRUMBULL, TUSCARAWAS, UNION, VAN WERT,  
VINTON, WARREN, WASHINGTON, WAYNE,  
WILLIAMS, WOOD, WYANDOT

**Special Jurisdictional Note :**

**Details :**

\*\* Asphalt - Oil spray bar man when operating from cab shall receive \$0.20 cents per hour above their Basic Hourly Rate.

# Prevailing Wage Rate Skilled Crafts

Name of Union: Electrical Local 129 Inside

Change # : LCN01-2021fbLoc129in

Craft : Electrical Effective Date : 04/28/2021 Last Posted : 04/28/2021

	BHR		Fringe Benefit Payments					Irrevocable Fund		Total PWR	Overtime Rate	
			H&W	Pension	App Tr.	Vac.	Annuity	Other	LECET (*)			MISC (*)
<b>Classification</b>												
Electrician	\$36.40		\$8.35	\$8.79	\$0.57	\$0.00	\$0.00	\$0.00	\$0.00	\$0.00	\$54.11	\$72.31
<b>Apprentice</b>	<b>Percent</b>											
1st 6 months	40.00	\$14.56	\$8.35	\$0.44	\$0.57	\$0.00	\$0.00	\$0.00	\$0.00	\$0.00	\$23.92	\$31.20
2nd 6 months	45.00	\$16.38	\$8.35	\$0.49	\$0.57	\$0.00	\$0.00	\$0.00	\$0.00	\$0.00	\$25.79	\$33.98
2nd yr	50.00	\$18.20	\$8.35	\$8.25	\$0.57	\$0.00	\$0.00	\$0.00	\$0.00	\$0.00	\$35.37	\$44.47
3rd yr	60.00	\$21.84	\$8.35	\$8.36	\$0.57	\$0.00	\$0.00	\$0.00	\$0.00	\$0.00	\$39.12	\$50.04
4th yr	70.00	\$25.48	\$8.35	\$8.46	\$0.57	\$0.00	\$0.00	\$0.00	\$0.00	\$0.00	\$42.86	\$55.60
5th yr	85.00	\$30.94	\$8.35	\$8.63	\$0.57	\$0.00	\$0.00	\$0.00	\$0.00	\$0.00	\$48.49	\$63.96

**Special Calculation Note :** No special calculations for this skilled craft wage rate are required at this time.

## Ratio :

1-3 Journeymen to 2 Apprentice  
4-6 Journeyman to 4 Apprentices

## Jurisdiction ( \* denotes special jurisdictional note ) :

ERIE, HURON\*, LORAIN\*, MEDINA\*

**Special Jurisdictional Note :** In Huron County the following townships are included: Bronson, Clarksfield, Fairfield, Fitchville, Greenfield, Hartland, Lyme, New London, Norwalk, Norwich, Peru, Ridgefield, Sherman, Townsend and Wakeman. In Medina County the following townships are included: Litchfield and Liverpool.

In Lorain County the following township is excluded: Columbia Township

## Details :

# Prevailing Wage Rate Skilled Crafts

Name of Union: Electrical Local 129 Inside Lt Commercial Northern

Change # : LCN02-2019fbLoc129in

Craft : Electrical Effective Date : 01/01/2019 Last Posted : 12/11/2019

	BHR		Fringe Benefit Payments					Irrevocable Fund		Total PWR	Overtime Rate	
			H&W	Pension	App Tr.	Vac.	Annuity	Other	LECET (*)			MISC (*)
Classification												
Electrician	\$34.35		\$8.35	\$8.38	\$0.57	\$0.00	\$0.00	\$0.00	\$0.00	\$0.00	\$51.65	\$68.82
CE-3 12,001- 14,000 Hrs	\$25.63		\$6.15	\$0.77	\$0.83	\$0.00	\$0.77	\$0.10	\$0.00	\$0.00	\$34.25	\$47.07
CE-2 10,001- 12,000 Hrs	\$20.14		\$6.15	\$0.60	\$0.83	\$0.00	\$0.60	\$0.10	\$0.00	\$0.00	\$28.42	\$38.49
CE-1 8,001- 10,000 Hrs	\$18.31		\$6.15	\$0.55	\$0.83	\$0.00	\$0.55	\$0.10	\$0.00	\$0.00	\$26.49	\$35.64
CW-4 6,001- 8,000 Hrs	\$16.48		\$6.15	\$0.49	\$0.83	\$0.00	\$0.49	\$0.10	\$0.00	\$0.00	\$24.54	\$32.78
CW-3 4,001- 6,000 Hrs	\$14.65		\$6.15	\$0.44	\$0.83	\$0.00	\$0.44	\$0.10	\$0.00	\$0.00	\$22.61	\$29.94
CW-2 2,001- 4,000 Hrs	\$13.73		\$6.15	\$0.41	\$0.83	\$0.00	\$0.41	\$0.10	\$0.00	\$0.00	\$21.63	\$28.49
CW-1 0- 2,000 Hrs	\$12.82		\$6.15	\$0.38	\$0.83	\$0.00	\$0.38	\$0.10	\$0.00	\$0.00	\$20.66	\$27.07
<b>Apprentice</b>	<b>Percent</b>											
1st 6 months	40.00	\$13.74	\$8.35	\$0.41	\$0.57	\$0.00	\$0.00	\$0.00	\$0.00	\$0.00	\$23.07	\$29.94
2nd 6 months	45.00	\$15.46	\$8.35	\$0.46	\$0.57	\$0.00	\$0.00	\$0.00	\$0.00	\$0.00	\$24.84	\$32.57
2nd yr	50.00	\$17.17	\$8.35	\$0.78	\$0.57	\$0.00	\$0.00	\$0.00	\$0.00	\$0.00	\$33.96	\$42.55
3rd yr	60.00	\$20.61	\$8.35	\$0.79	\$0.57	\$0.00	\$0.00	\$0.00	\$0.00	\$0.00	\$37.50	\$47.81
4th yr	70.00	\$24.04	\$8.35	\$0.80	\$0.57	\$0.00	\$0.00	\$0.00	\$0.00	\$0.00	\$41.03	\$53.06
5th yr	85.00	\$29.20	\$8.35	\$0.83	\$0.57	\$0.00	\$0.00	\$0.00	\$0.00	\$0.00	\$46.35	\$60.95

**Special Calculation Note :** Other is Administration Fee.

**Ratio :**

**Jurisdiction ( \* denotes special jurisdictional note ) :**

# Prevailing Wage Rate Skilled Crafts

Name of Union: Electrical Local 129 Lightning Protection

Change # : LCN01-2020fbLoc129in

Craft : Electrical Effective Date : 06/29/2020 Last Posted : 06/25/2020

	BHR		Fringe Benefit Payments					Irrevocable Fund		Total PWR	Overtime Rate	
			H&W	Pension	App Tr.	Vac.	Annuity	Other	LECET (*)			MISC (*)
Classification												
Electrical Lightning Protection Installer	\$30.44		\$7.50	\$0.91	\$0.00	\$2.84	\$1.83	\$0.00	\$0.00	\$0.00	\$43.52	\$58.74
Apprentice	Percent											
1st 6 months	50.00	\$15.22	\$7.50	\$0.46	\$0.00	\$0.00	\$0.91	\$0.41	\$0.00	\$0.00	\$24.50	\$32.11
2nd 6 months	55.00	\$16.74	\$7.50	\$0.50	\$0.00	\$0.00	\$1.00	\$0.45	\$0.00	\$0.00	\$26.19	\$34.56
3rd 6 months	60.00	\$18.26	\$7.50	\$0.55	\$0.00	\$0.89	\$1.10	\$0.00	\$0.00	\$0.00	\$28.30	\$37.44
4th 6 months	65.00	\$19.79	\$7.50	\$0.59	\$0.00	\$0.97	\$1.19	\$0.00	\$0.00	\$0.00	\$30.04	\$39.93
3rd year	70.00	\$21.31	\$7.50	\$0.64	\$0.00	\$1.52	\$1.28	\$0.00	\$0.00	\$0.00	\$32.25	\$42.90
4th year	80.00	\$24.35	\$7.50	\$0.73	\$0.00	\$1.73	\$1.46	\$0.00	\$0.00	\$0.00	\$35.77	\$47.95
5th year	90.00	\$27.40	\$7.50	\$0.82	\$0.00	\$1.95	\$1.64	\$0.00	\$0.00	\$0.00	\$39.31	\$53.00

**Special Calculation Note :** OTHER is Holiday Pay

**Ratio :**

None

**Jurisdiction ( \* denotes special jurisdictional note ):**

ERIE, HURON\*, LORAIN\*, MEDINA\*

**Special Jurisdictional Note :** In Huron County the following townships are included: Bronson, Clarksfield, Fairfield, Fitchville, Greenfield, Hartland, Lyme, New London, Norwalk, Norwich, Peru, Ridgefield, Sherman, Townsend and Wakeman. In Medina County the following townships are included: Litchfield and Liverpool.

In Lorain County the following township is excluded: Columbia.

**Details :**

# Prevailing Wage Rate Skilled Crafts

Name of Union: Electrical Local 38 Lightning Rod

Change # : LCN01-2020fbLoc38

Craft : Electrical Effective Date : 06/29/2020 Last Posted : 06/25/2020

	BHR		Fringe Benefit Payments						Irrevocable Fund		Total PWR	Overtime Rate
			H&W	Pension	App Tr.	Vac.	Annuity	Other	LECET (*)	MISC (*)		
<b>Classification</b>												
Electrical Lightning Protection Installer 60 months and up	\$30.44		\$7.50	\$0.91	\$0.00	\$2.84	\$1.83	\$0.00	\$0.00	\$0.00	\$43.52	\$58.74
<b>Experience Level</b>	<b>Percent</b>											
Apprentice Lightning Protection Installer 1st day-6 months	50.00	\$15.22	\$7.50	\$0.46	\$0.00	\$0.00	\$0.92	\$0.41	\$0.00	\$0.00	\$24.51	\$32.12
Apprentice Lightning Protection Installer 2nd 6 months	55.00	\$16.74	\$7.50	\$0.50	\$0.00	\$0.00	\$1.01	\$0.45	\$0.00	\$0.00	\$26.20	\$34.57
Apprentice Lightning Protection Installer 3rd 6 months	60.00	\$18.26	\$7.50	\$0.55	\$0.00	\$0.89	\$1.10	\$0.00	\$0.00	\$0.00	\$28.30	\$37.44
Apprentice Lightning Protection Installer 4th 6 months	65.00	\$19.79	\$7.50	\$0.59	\$0.00	\$0.97	\$1.19	\$0.00	\$0.00	\$0.00	\$30.04	\$39.93
Apprentice Lightning Protection Installer 3rd Year	70.00	\$21.31	\$7.50	\$0.64	\$0.00	\$1.52	\$1.28	\$0.00	\$0.00	\$0.00	\$32.25	\$42.90
Apprentice	80.00	\$24.35	\$7.50	\$0.73	\$0.00	\$1.73	\$1.46	\$0.00	\$0.00	\$0.00	\$35.77	\$47.95

Lightning Protection Installer 4th Year												
Apprentice Lightning Protection Installer 5th Year	90.00	\$27.40	\$7.50	\$0.82	\$0.00	\$1.95	\$1.65	\$0.00	\$0.00	\$0.00	\$39.32	\$53.01

**Special Calculation Note :** Other is Holiday.

**Ratio :** 3 Journeyman to 1 Apprentice

**Jurisdiction ( \* denotes special jurisdictional note ):** CUYAHOGA, GEAUGA\*, LORAIN\*

**Special Jurisdictional Note :** In Geauga County the following townships are included: (Bainbridge, Chester and Russell). In Lorain County the following township is included (Columbia).

**Details :**  
 Scope of work but not limited to: The installation, operation, maintenance, repair and service of equipment and appliances used in a system of lightning protection systems.  
 Intermediate Journeymen to be trained by the employer to meet all standards in the industry.

# Prevailing Wage Rate Skilled Crafts

Name of Union: Electrical Local 129 Voice Data Video

Change # : LCN01-2020fbLoc129VDV

Craft : Voice Data Video Effective Date : 04/27/2020 Last Posted : 04/23/2020

	BHR		Fringe Benefit Payments						Irrevocable Fund		Total PWR	Overtime Rate
			H&W	Pension	App Tr.	Vac.	Annuity	Other	LECET (*)	MISC (*)		
Classification												
Electrical Installer Technician	\$27.30		\$7.75	\$3.77	\$0.42	\$1.23	\$0.00	\$0.00	\$0.00	\$0.00	\$40.47	\$54.12
Communications Technician	\$28.55		\$7.75	\$3.81	\$0.42	\$1.28	\$0.00	\$0.00	\$0.00	\$0.00	\$41.81	\$56.09
Senior Technician	\$29.55		\$7.75	\$3.84	\$0.42	\$1.33	\$0.00	\$0.00	\$0.00	\$0.00	\$42.89	\$57.67
Security Technician Level I	\$27.30		\$7.75	\$3.77	\$0.42	\$1.23	\$0.00	\$0.00	\$0.00	\$0.00	\$40.47	\$54.12
Security Technician Level II	\$28.55		\$7.75	\$3.81	\$0.42	\$1.28	\$0.00	\$0.00	\$0.00	\$0.00	\$41.81	\$56.09
Security Technician Level III	\$29.55		\$7.75	\$3.84	\$0.42	\$1.33	\$0.00	\$0.00	\$0.00	\$0.00	\$42.89	\$57.67
Audio/Visual Technician Level I	\$27.30		\$7.75	\$3.77	\$0.42	\$1.23	\$0.00	\$0.00	\$0.00	\$0.00	\$40.47	\$54.12
Audio/Visual Technician Level II	\$28.55		\$7.75	\$3.81	\$0.42	\$1.28	\$0.00	\$0.00	\$0.00	\$0.00	\$41.81	\$56.09
Audio/Visual Technician Level III	\$29.55		\$7.75	\$3.84	\$0.42	\$1.33	\$0.00	\$0.00	\$0.00	\$0.00	\$42.89	\$57.67
Apprentice	Percent											
1st 750 hours	55.00	\$15.02	\$7.75	\$3.40	\$0.42	\$0.68	\$0.00	\$0.00	\$0.00	\$0.00	\$27.26	\$34.77
2nd 750 hours	65.02	\$17.75	\$7.75	\$3.49	\$0.42	\$0.80	\$0.00	\$0.00	\$0.00	\$0.00	\$30.21	\$39.09
3rd 750 hours	75.00	\$20.48	\$7.75	\$3.57	\$0.42	\$0.92	\$0.00	\$0.00	\$0.00	\$0.00	\$33.14	\$43.37
4th 750 hours	80.00	\$21.84	\$7.75	\$3.61	\$0.42	\$0.98	\$0.00	\$0.00	\$0.00	\$0.00	\$34.60	\$45.52
5th 750 hours	85.02	\$23.21	\$7.75	\$3.65	\$0.42	\$1.04	\$0.00	\$0.00	\$0.00	\$0.00	\$36.07	\$47.68
6th 750 hours	90.00	\$24.57	\$7.75	\$3.69	\$0.42	\$1.11	\$0.00	\$0.00	\$0.00	\$0.00	\$37.54	\$49.83

**Special Calculation Note :** No special calculations for this skilled craft wage rate are required at this time.

**Ratio :**

1 Journeyman to 1 Apprentice

**Jurisdiction ( \* denotes special jurisdictional note ):**

ERIE, HURON\*, LORAIN\*, MEDINA\*

**Special Jurisdictional Note :** In Huron County the following townships are included: (Lyme, Ridgefield, Norwalk, Townsend, Wakeman, Sherman, Peru, Bronson, Hartland, Clarksfield, Norwich, Greenfield, Fairfield, Fitchville and New London). In Lorain County the following townships are excluded: (Columbia). In Medina County the following townships are included: (Litchfield and Liverpool).

**Details :**

An employee who is required to wear a pager after hours will receive an additional 1.00 per hour for all hours worked.

Vacation: 1 week for 1 year

2 weeks for 2 years or more

Holidays: Memorial Day - Fourth of July - Labor Day - Thanksgiving Day - Christmas Day - New Years Day

The following work is excluded from the Teledata Technician work scope:

The installation of computer systems in industrial applications such as assembly lines, robotics, computer controller manufacturing systems.

The installation of conduit and/ or raceways shall be installed by Inside Wireman . On sites where there is no Inside Wireman employed, the Teledata Technician may install raceway, or conduit not greater then 10 ft.

Fire Alarm work is excluded on all new construction sites or wherever the fire alarm system is installed in conduit

All HVAC control work.

# Prevailing Wage Rate Skilled Crafts

Name of Union: Electrical Local 38

Change # : LCN01-2020fbLoc38

Craft : Electrical Effective Date : 04/30/2020 Last Posted : 04/30/2020

	BHR		Fringe Benefit Payments					Irrevocable Fund		Total PWR	Overtime Rate	
			H&W	Pension	App Tr.	Vac.	Annuity	Other	LECET (*)			MISC (*)
Classification												
Electrician	\$39.88		\$9.05	\$10.05	\$0.42	\$0.00	\$0.50	\$1.20	\$0.00	\$0.00	\$61.10	\$81.04
<b>Apprentice</b>	<b>Percent</b>											
1st year 1st 6 Months	35.00	\$13.96	\$9.05	\$0.00	\$0.42	\$0.00	\$0.50	\$0.42	\$0.00	\$0.00	\$24.35	\$31.33
1st year 2nd 6 Months	40.00	\$15.95	\$9.05	\$0.00	\$0.42	\$0.00	\$0.50	\$0.48	\$0.00	\$0.00	\$26.40	\$34.38
2nd year 3rd 6 Months	45.00	\$17.95	\$9.05	\$6.53	\$0.42	\$0.00	\$0.50	\$0.54	\$0.00	\$0.00	\$34.99	\$43.96
2nd year 4th 6 Months	50.00	\$19.94	\$9.05	\$6.53	\$0.42	\$0.00	\$0.50	\$0.60	\$0.00	\$0.00	\$37.04	\$47.01
3rd year 5th 6 Months	55.00	\$21.93	\$9.05	\$6.53	\$0.42	\$0.00	\$0.50	\$0.66	\$0.00	\$0.00	\$39.09	\$50.06
3rd year 3rd year 6th 6 Months	60.00	\$23.93	\$9.05	\$6.53	\$0.42	\$0.00	\$0.50	\$0.72	\$0.00	\$0.00	\$41.15	\$53.11
4th year 7th 6 Months	65.00	\$25.92	\$9.05	\$6.53	\$0.42	\$0.00	\$0.50	\$0.78	\$0.00	\$0.00	\$43.20	\$56.16
4th year 8th 6 Months	70.00	\$27.92	\$9.05	\$6.53	\$0.42	\$0.00	\$0.50	\$0.84	\$0.00	\$0.00	\$45.26	\$59.21
4th year 9th 6 Months	75.00	\$29.91	\$9.05	\$6.53	\$0.42	\$0.00	\$0.50	\$0.90	\$0.00	\$0.00	\$47.31	\$62.27
5th year 10th 6 Months	80.00	\$31.90	\$9.05	\$6.53	\$0.42	\$0.00	\$0.50	\$0.96	\$0.00	\$0.00	\$49.36	\$65.32

**Special Calculation Note** : OTHER: National Electrical Benefit Fund (NEBF).

**Ratio** :

1 to 3 Journeyman up to 2 Apprentice  
4 to 6 Journeymen up to 4 Apprentice  
7 to 9 Journeymen up to 6 Apprentice

**Jurisdiction ( \* denotes special jurisdictional note )**:

CUYAHOGA, GEAUGA\*, LORAIN\*

and continue as above per job site

**Special Jurisdictional Note :** In Geauga County the following townships are included: (Bainbridge, Chester and Russell). In Lorain County the following township is included (Columbia Twp).

**Details :**

# Prevailing Wage Rate Skilled Crafts

Name of Union: Electrical Local 38 Lt Commercial Northern

Change # : LCN01-2021fbLoc38

Craft : Electrical Effective Date : 01/20/2021 Last Posted : 01/20/2021

	BHR		Fringe Benefit Payments					Irrevocable Fund		Total PWR	Overtime Rate	
			H&W	Pension	App Tr.	Vac.	Annuity	Other	LECET (*)			MISC (*)
Classification												
Electrician	\$39.88		\$9.05	\$10.05	\$0.42	\$0.00	\$0.00	\$1.20	\$0.00	\$0.00	\$60.60	\$80.54
CE-3 12,001- 14,000 Hrs	\$26.31		\$6.35	\$0.00	\$0.84	\$0.00	\$0.79	\$0.79	\$0.00	\$0.10	\$35.18	\$48.34
CE-2 10,001- 12,000 Hrs	\$20.67		\$6.35	\$0.00	\$0.84	\$0.00	\$0.62	\$0.62	\$0.00	\$0.10	\$29.20	\$39.54
CE-1 8,001- 10,000 Hrs	\$18.79		\$6.35	\$0.00	\$0.84	\$0.00	\$0.56	\$0.56	\$0.00	\$0.10	\$27.20	\$36.60
CW-4 6,001-8,000 Hrs	\$16.91		\$6.35	\$0.00	\$0.84	\$0.00	\$0.51	\$0.51	\$0.00	\$0.10	\$25.22	\$33.68
CW-3 4,000-6,000 Hrs	\$15.03		\$6.35	\$0.00	\$0.84	\$0.00	\$0.45	\$0.45	\$0.00	\$0.10	\$23.22	\$30.73
CW-2 2,001-4,000 Hrs	\$14.09		\$6.35	\$0.00	\$0.84	\$0.00	\$0.42	\$0.42	\$0.00	\$0.10	\$22.22	\$29.27
CW-1 0- 2,000 Hrs	\$13.15		\$6.35	\$0.00	\$0.84	\$0.00	\$0.39	\$0.39	\$0.00	\$0.10	\$21.22	\$27.80
<b>Apprentice</b>	<b>Percent</b>											
1st 6 Months	35.00	\$13.96	\$9.05	\$0.00	\$0.42	\$0.00	\$0.50	\$0.42	\$0.00	\$0.00	\$24.35	\$31.33
2nd 6 Months	40.00	\$15.95	\$9.05	\$0.00	\$0.42	\$0.00	\$0.50	\$0.48	\$0.00	\$0.00	\$26.40	\$34.38
3rd 6 Months	45.00	\$17.95	\$9.05	\$6.53	\$0.42	\$0.00	\$0.50	\$0.54	\$0.00	\$0.00	\$34.99	\$43.96
4th 6 Months	50.00	\$19.94	\$9.05	\$6.53	\$0.42	\$0.00	\$0.50	\$0.60	\$0.00	\$0.00	\$37.04	\$47.01
5th 6 Months	55.00	\$21.93	\$9.05	\$6.53	\$0.42	\$0.00	\$0.50	\$0.66	\$0.00	\$0.00	\$39.09	\$50.06
6th 6 Months	60.00	\$23.93	\$9.05	\$6.53	\$0.42	\$0.00	\$0.50	\$0.72	\$0.00	\$0.00	\$41.15	\$53.11
7th 6	65.00	\$25.92	\$9.05	\$6.53	\$0.42	\$0.00	\$0.50	\$0.78	\$0.00	\$0.00	\$43.20	\$56.16

Months												
8th 6 Months	70.00	\$27.92	\$9.05	\$6.53	\$0.42	\$0.00	\$0.50	\$0.84	\$0.00	\$0.00	\$45.26	\$59.21
9th 6 Months	75.00	\$29.91	\$9.05	\$6.53	\$0.42	\$0.00	\$0.50	\$0.90	\$0.00	\$0.00	\$47.31	\$62.27
10th 6 Months	80.00	\$31.90	\$9.05	\$6.53	\$0.42	\$0.00	\$0.50	\$0.96	\$0.00	\$0.00	\$49.36	\$65.32

**Special Calculation Note :** OTHER: National Electrical Benefit Fund (NEBF).

**Ratio :**

1 to 3 Journeyman to 2 Apprentice  
 4 to 6 Journeymen to 4 Apprentice  
 7 to 9 Journeymen to 6 Apprentice  
 and continue as above per job site

**Jurisdiction ( \* denotes special jurisdictional note ):**

CUYAHOGA, GEAUGA\*, LORAIN\*

**Construction Electrician and Construction Wireman Ratio**

There shall be a minimum ratio of one inside Journeyman Wireman to every (4) employees of different classifications per jobsite. An Inside Journeyman Wireman is required on the project as the fifth (5th) worker or when apprentices are used.

**Special Jurisdictional Note :** In Geauga County the following townships are included: (Bainbridge, Chester and Russell). In Lorain County the following township is included (Columbia).

The scope of work for the light commercial agreement shall apply to the following small medical clinics, stand-alone doctor and dentist offices with up to 600 amp service (not attached to a hospital), gas stations/convenience stores, fast food restaurants and franchised chain restaurants including independent bars and taverns, places of worship, funeral homes, nursing homes, assisted living facilities and day-care facilities under 15,000 sq ft, small office, retail/wholesale facilities under 15,000 sq ft with less than 10 units attached, storage units, car washes, express hotels and motels (4 stories or less) without conference or restaurants facilities, residential units (subject to Davis Bacon Rates) small stand-alone manufacturing facilities when free standing and not part of a larger facility (less than 15,000 sq ft) solar projects (500 panels or less) unless other wise covered under this agreement, lighting retrofits (when not associated with remodels involving branch re-circuiting) Lighting retrofits shall be defined as the changing of lamps and ballasts in existing light fixtures and shall also include the one for one replacement of existing fixtures.

**Details :**

# Prevailing Wage Rate

## Skilled Crafts

Name of Union: Electrical Local 38 Voice Data Video

Change # : LCN01-2021fbLoc38VDV

Craft : Voice Data Video Effective Date : 04/28/2021 Last Posted : 04/28/2021

	BHR		Fringe Benefit Payments					Irrevocable Fund		Total PWR	Overtime Rate	
			H&W	Pension	App Tr.	Vac.	Annuity	Other	LECET (*)			MISC (*)
Classification												
Electrical Installer Technician	\$27.55		\$7.75	\$3.20	\$0.42	\$1.24	\$0.50	\$0.86	\$0.00	\$0.00	\$41.52	\$55.30
Communication Technician	\$28.80		\$7.75	\$3.20	\$0.42	\$1.30	\$0.50	\$0.90	\$0.00	\$0.00	\$42.87	\$57.27
Senior Technician	\$29.80		\$7.75	\$3.20	\$0.42	\$1.34	\$0.50	\$0.93	\$0.00	\$0.00	\$43.94	\$58.84
Security Technician Level I	\$27.55		\$7.75	\$3.20	\$0.42	\$1.24	\$0.50	\$0.86	\$0.00	\$0.00	\$41.52	\$55.30
Security Technician Level II	\$28.80		\$7.75	\$3.20	\$0.42	\$1.30	\$0.50	\$0.90	\$0.00	\$0.00	\$42.87	\$57.27
Security Technician Level III	\$29.80		\$7.75	\$3.20	\$0.42	\$1.34	\$0.50	\$0.93	\$0.00	\$0.00	\$43.94	\$58.84
Audio/Visual Technician Level I	\$27.55		\$7.75	\$3.20	\$0.42	\$1.24	\$0.50	\$0.86	\$0.00	\$0.00	\$41.52	\$55.30
Audio/Visual Technician Level II	\$28.80		\$7.75	\$3.20	\$0.42	\$1.30	\$0.50	\$0.90	\$0.00	\$0.00	\$42.87	\$57.27
Audio/Visual Technician Level III	\$29.80		\$7.75	\$3.20	\$0.42	\$1.34	\$0.50	\$0.93	\$0.00	\$0.00	\$43.94	\$58.84
<b>Apprentice</b>	<b>Percent</b>											
1st 6 months	55.00	\$15.15	\$7.75	\$3.20	\$0.42	\$0.68	\$0.50	\$0.47	\$0.00	\$0.00	\$28.17	\$35.75
2nd 6 months	65.00	\$17.91	\$7.75	\$3.20	\$0.42	\$0.81	\$0.50	\$0.56	\$0.00	\$0.00	\$31.15	\$40.10
3rd 6 months	75.00	\$20.66	\$7.75	\$3.20	\$0.42	\$0.93	\$0.50	\$0.65	\$0.00	\$0.00	\$34.11	\$44.44
4th 6 months	80.00	\$22.04	\$7.75	\$3.20	\$0.42	\$0.99	\$0.50	\$0.69	\$0.00	\$0.00	\$35.59	\$46.61
5th 6 months	85.00	\$23.42	\$7.75	\$3.20	\$0.42	\$1.05	\$0.50	\$0.73	\$0.00	\$0.00	\$37.07	\$48.78
6th 6 months	90.00	\$24.80	\$7.75	\$3.20	\$0.42	\$1.12	\$0.50	\$0.78	\$0.00	\$0.00	\$38.57	\$50.96

**Special Calculation Note :** Other is National Electrical Benefit Fund.

**Ratio :**

1 Journeyman to 1 Apprentice

**Jurisdiction ( \* denotes special jurisdictional note ) :**

CUYAHOGA, GEAUGA\*, LORAIN\*

**Special Jurisdictional Note :** In Geauga County the following townships are included (Bainbridge, Chester and Russell). In Lorain County the following township is included (Columbia Twp.).

**Details :**

\*Installer Technician - Successful completion of the Installer/Tech Apprenticeship Program or have been certified by an IBEW/NECA Joint apprenticeship Program as a Installer/Technician.

\* Communications Technician - At least (2) years experience as a Installer/Technician and a minimum of 12 hours continuous related education or have been certified by an IBEW/NECA Joint Apprenticeship and Training Program as a Communications/Technician.

The following work is excluded from the Teledata Technician work scope:

The installation of computer systems in industrial applications such as assembly lines, robotics, computer controller manufacturing systems.

The installation of conduit and/ or raceways shall be installed by Inside Wireman . On sites where there is no Inside Wireman employed, the Teledata Technician may install raceway, or conduit not greater than 10 ft.

Fire Alarm work is excluded on all new construction sites or wherever the fire alarm system is installed in conduit

All HVAC control work.

# Prevailing Wage Rate

## Skilled Crafts

Name of Union: Roofer Local 44

Change # : LCN01-2019fbLoc44

Craft : Roofer Effective Date : 06/19/2019 Last Posted : 06/19/2019

	BHR		Fringe Benefit Payments					Irrevocable Fund		Total PWR	Overtime Rate	
			H&W	Pension	App Tr.	Vac.	Annuity	Other	LECET (*)			MISC (*)
Classification												
Roofer	\$33.65		\$9.15	\$9.75	\$0.28	\$0.00	\$0.00	\$0.06	\$0.00	\$0.00	\$52.89	\$69.71
Waterproofers	\$35.80		\$9.10	\$9.35	\$0.28	\$0.00	\$0.00	\$0.06	\$0.00	\$0.00	\$54.59	\$72.49
Applicant & Helper Trainees												
0 to 1851 hrs	\$13.75		\$0.40	\$0.50	\$0.28	\$0.00	\$0.00	\$0.06	\$0.00	\$0.00	\$14.99	\$21.86
1852 to 3350 hrs	\$18.51		\$9.15	\$9.75	\$0.28	\$0.00	\$0.00	\$0.06	\$0.00	\$0.00	\$37.75	\$47.01
3351 to 4850 hrs	\$23.56		\$9.15	\$9.75	\$0.28	\$0.00	\$0.00	\$0.06	\$0.00	\$0.00	\$42.80	\$54.58
4851 to 6350 hrs	\$26.92		\$9.15	\$9.75	\$0.28	\$0.00	\$0.00	\$0.06	\$0.00	\$0.00	\$46.16	\$59.62
6351 to 7550 hrs	\$30.29		\$9.15	\$9.75	\$0.28	\$0.00	\$0.00	\$0.06	\$0.00	\$0.00	\$49.53	\$64.68
7551 hrs	\$33.65		\$9.15	\$9.75	\$0.28	\$0.00	\$0.00	\$0.06	\$0.00	\$0.00	\$52.89	\$69.71
<b>Apprentice</b>	<b>Percent</b>											
Start of school	40.85	\$13.75	\$0.40	\$0.50	\$0.28	\$0.00	\$0.00	\$0.06	\$0.00	\$0.00	\$14.99	\$21.86
600 hrs worked/72 school hrs	45.00	\$15.14	\$0.40	\$0.50	\$0.28	\$0.00	\$0.00	\$0.06	\$0.00	\$0.00	\$16.38	\$23.95
1200 hrs worked/144 school hrs	50.00	\$16.82	\$9.15	\$9.75	\$0.28	\$0.00	\$0.00	\$0.06	\$0.00	\$0.00	\$36.07	\$44.48
1800 hrs worked/216 school hrs	55.00	\$18.51	\$9.15	\$9.75	\$0.28	\$0.00	\$0.00	\$0.06	\$0.00	\$0.00	\$37.75	\$47.00
2400 hrs worked/ 288 school hrs	60.00	\$20.19	\$9.15	\$9.75	\$0.28	\$0.00	\$0.00	\$0.06	\$0.00	\$0.00	\$39.43	\$49.53
3000 hrs worked/360 school hrs	70.00	\$23.55	\$9.15	\$9.75	\$0.28	\$0.00	\$0.00	\$0.06	\$0.00	\$0.00	\$42.80	\$54.57
3600 hrs	80.00	\$26.92	\$9.15	\$9.75	\$0.28	\$0.00	\$0.00	\$0.06	\$0.00	\$0.00	\$46.16	\$59.62

worked/432 school hrs												
4200 hrs worked/504 school hrs	90.00	\$30.28	\$9.15	\$9.75	\$0.28	\$0.00	\$0.00	\$0.06	\$0.00	\$0.00	\$49.53	\$64.67
4800 hrs/576 school hrs	100.00	\$33.65	\$9.15	\$9.75	\$0.28	\$0.00	\$0.00	\$0.06	\$0.00	\$0.00	\$52.89	\$69.71

**Special Calculation Note :** Other is for Drug Testing.

**Ratio :**

2 Journeymen to 1 Apprentice  
1 Applicant/Helper Trainee

**Jurisdiction ( \* denotes special jurisdictional note ) :**

ASHTABULA, CUYAHOGA, ERIE, GEAUGA,  
LAKE, LORAIN\*, SANDUSKY

**Special Jurisdictional Note :** Lorain (The Ohio Turnpike North)

**Details :**

\$0.04 for "Other" is for Drug Testing

# Prevailing Wage Rate Skilled Crafts

Name of Union: Roofer Local 88

Change # : LCN01-2020fbLoc88

Craft : Roofer Effective Date : 06/04/2020 Last Posted : 06/04/2020

	BHR		Fringe Benefit Payments					Irrevocable Fund		Total PWR	Overtime Rate	
			H&W	Pension	App Tr.	Vac.	Annuity	Other	LECET (*)			MISC (*)
Classification												
Roofer	\$27.00		\$8.90	\$8.95	\$0.40	\$0.00	\$1.25	\$0.15	\$0.00	\$0.00	\$46.65	\$60.15
HELPERS												
Helper -500 Hrs. 1st 6 months	\$15.12		\$2.25	\$0.00	\$0.40	\$0.00	\$1.25	\$0.15	\$0.00	\$0.00	\$19.17	\$26.73
Helper - 500 Hrs. 2nd 6 months	\$16.74		\$8.90	\$8.95	\$0.40	\$0.00	\$1.25	\$0.15	\$0.00	\$0.00	\$36.39	\$44.76
2nd year Helper	\$18.36		\$8.90	\$8.95	\$0.40	\$0.00	\$1.25	\$0.15	\$0.00	\$0.00	\$38.01	\$47.19
3rd year Helper	\$19.98		\$8.90	\$8.95	\$0.40	\$0.00	\$1.25	\$0.15	\$0.00	\$0.00	\$39.63	\$49.62
4th year Helper	\$21.60		\$8.90	\$8.95	\$0.40	\$0.00	\$1.25	\$0.15	\$0.00	\$0.00	\$41.25	\$52.05
5th year Helper	\$23.22		\$8.90	\$8.95	\$0.40	\$0.00	\$1.25	\$0.15	\$0.00	\$0.00	\$42.87	\$54.48
6th year Helper	\$24.84		\$8.90	\$8.95	\$0.40	\$0.00	\$1.25	\$0.15	\$0.00	\$0.00	\$44.49	\$56.91
<b>Apprentice</b>												
	Percent											
1st 6 months w/500 hrs	56.00	\$15.12	\$8.90	\$8.95	\$0.40	\$0.00	\$1.25	\$0.15	\$0.00	\$0.00	\$34.77	\$42.33
2nd 6 months w/500 hrs	62.00	\$16.74	\$8.90	\$8.95	\$0.40	\$0.00	\$1.25	\$0.15	\$0.00	\$0.00	\$36.39	\$44.76
3rd 6 months w/500 hrs	68.00	\$18.36	\$8.90	\$8.95	\$0.40	\$0.00	\$1.25	\$0.15	\$0.00	\$0.00	\$38.01	\$47.19
4th 6 months w/500 hrs	74.00	\$19.98	\$8.90	\$8.95	\$0.40	\$0.00	\$1.25	\$0.15	\$0.00	\$0.00	\$39.63	\$49.62
5th 6 months w/500 hrs	80.00	\$21.60	\$8.90	\$8.95	\$0.40	\$0.00	\$1.25	\$0.15	\$0.00	\$0.00	\$41.25	\$52.05

6th 6 months w/500 hrs	86.00	\$23.22	\$8.90	\$8.95	\$0.40	\$0.00	\$1.25	\$0.15	\$0.00	\$0.00	\$42.87	\$54.48
7th 6 months w/500 hrs	92.00	\$24.84	\$8.90	\$8.95	\$0.40	\$0.00	\$1.25	\$0.15	\$0.00	\$0.00	\$44.49	\$56.91
8th 6 months w/500 hrs	100.00	\$27.00	\$8.90	\$8.95	\$0.40	\$0.00	\$1.25	\$0.15	\$0.00	\$0.00	\$46.65	\$60.15

**Special Calculation Note :** Roofers working in any form of coal tar pitch, whether hot or cold, installing and/or removing will be paid \$.25 more per hour.  
Other \$0.15 is for C.I.D.B.

**Ratio :**

No helper shall be used on any one job unless 1 Journeymen, and 1 Apprentices are working on said job .One  
(1) Journeymen to One (1) Apprentice to One (1) Helper

**Jurisdiction ( \* denotes special jurisdictional note ) :**

ASHLAND, CARROLL, COSHOCTON, CRAWFORD, HOLMES, HURON, LORAIN\*, MEDINA, PORTAGE, RICHLAND, STARK, SUMMIT, TUSCARAWAS, WAYNE

**Special Jurisdictional Note :** In Lorain County (South of the Turnpike)

**Details :**

This document has important legal consequences; consultation with an attorney is encouraged with respect to its use or modification. This document should be adapted to the particular circumstances of the contemplated Project and the controlling Laws and Regulations.

# STANDARD GENERAL CONDITIONS OF THE CONSTRUCTION CONTRACT

Prepared by

**ENGINEERS JOINT CONTRACT DOCUMENTS COMMITTEE**

and

Issued and Published Jointly by



AMERICAN COUNCIL OF ENGINEERING COMPANIES

ASSOCIATED GENERAL CONTRACTORS OF AMERICA

AMERICAN SOCIETY OF CIVIL ENGINEERS

PROFESSIONAL ENGINEERS IN PRIVATE PRACTICE  
*A Practice Division of the*  
NATIONAL SOCIETY OF PROFESSIONAL ENGINEERS

Endorsed by



CONSTRUCTION SPECIFICATIONS INSTITUTE

These General Conditions have been prepared for use with the Suggested Forms of Agreement Between Owner and Contractor (EJCDC C-520 or C-525, 2007 Editions). Their provisions are interrelated and a change in one may necessitate a change in the other. Comments concerning their usage are contained in the Narrative Guide to the EJCDC Construction Documents (EJCDC C-001, 2007 Edition). For guidance in the preparation of Supplementary Conditions, see Guide to the Preparation of Supplementary Conditions (EJCDC C-800, 2007 Edition).

Copyright © 2007 National Society of Professional Engineers  
1420 King Street, Alexandria, VA 22314-2794  
(703) 684-2882  
[www.nspe.org](http://www.nspe.org)

American Council of Engineering Companies  
1015 15th Street N.W., Washington, DC 20005  
(202) 347-7474  
[www.acec.org](http://www.acec.org)

American Society of Civil Engineers  
1801 Alexander Bell Drive, Reston, VA 20191-4400  
(800) 548-2723  
[www.asce.org](http://www.asce.org)

Associated General Contractors of America  
2300 Wilson Boulevard, Suite 400, Arlington, VA 22201-3308  
(703) 548-3118  
[www.agc.org](http://www.agc.org)

The copyright for this EJCDC document is owned jointly by the four EJCDC sponsoring organizations and held in trust for their benefit by NSPE.

# STANDARD GENERAL CONDITIONS OF THE CONSTRUCTION CONTRACT

## TABLE OF CONTENTS

	Page
Article 1 – Definitions and Terminology .....	7
1.01 Defined Terms.....	7
1.02 Terminology .....	11
Article 2 – Preliminary Matters.....	12
2.01 Delivery of Bonds and Evidence of Insurance.....	12
2.02 Copies of Documents.....	12
2.03 Commencement of Contract Times; Notice to Proceed.....	12
2.04 Starting the Work.....	12
2.05 Before Starting Construction .....	13
2.06 Preconstruction Conference; Designation of Authorized Representatives .....	13
2.07 Initial Acceptance of Schedules.....	13
Article 3 – Contract Documents: Intent, Amending, Reuse .....	14
3.01 Intent.....	14
3.02 Reference Standards.....	14
3.03 Reporting and Resolving Discrepancies.....	14
3.04 Amending and Supplementing Contract Documents.....	15
3.05 Reuse of Documents .....	15
3.06 Electronic Data.....	16
Article 4 – Availability of Lands; Subsurface and Physical Conditions; Hazardous Environmental Conditions; Reference Points.....	16
4.01 Availability of Lands .....	16
4.02 Subsurface and Physical Conditions .....	17
4.03 Differing Subsurface or Physical Conditions.....	17
4.04 Underground Facilities .....	18
4.05 Reference Points .....	19
4.06 Hazardous Environmental Condition at Site.....	20
Article 5 – Bonds and Insurance .....	21
5.01 Performance, Payment, and Other Bonds .....	21
5.02 Licensed Sureties and Insurers .....	22
5.03 Certificates of Insurance .....	22
5.04 Contractor’s Insurance.....	23
5.05 Owner’s Liability Insurance .....	24
5.06 Property Insurance .....	24
5.07 Waiver of Rights .....	25
5.08 Receipt and Application of Insurance Proceeds.....	26
5.09 Acceptance of Bonds and Insurance; Option to Replace.....	27

5.10	Partial Utilization, Acknowledgment of Property Insurer .....	27
Article 6 –	Contractor’s Responsibilities .....	27
6.01	Supervision and Superintendence.....	27
6.02	Labor; Working Hours.....	28
6.03	Services, Materials, and Equipment .....	28
6.04	Progress Schedule .....	28
6.05	Substitutes and “Or-Equals” .....	28
6.06	Concerning Subcontractors, Suppliers, and Others.....	31
6.07	Patent Fees and Royalties .....	32
6.08	Permits.....	33
6.09	Laws and Regulations .....	33
6.10	Taxes .....	33
6.11	Use of Site and Other Areas .....	33
6.12	Record Documents.....	34
6.13	Safety and Protection .....	34
6.14	Safety Representative.....	35
6.15	Hazard Communication Programs .....	35
6.16	Emergencies .....	36
6.17	Shop Drawings and Samples .....	36
6.18	Continuing the Work.....	38
6.19	Contractor’s General Warranty and Guarantee.....	38
6.20	Indemnification .....	38
6.21	Delegation of Professional Design Services .....	39
Article 7 –	Other Work at the Site.....	40
7.01	Related Work at Site .....	40
7.02	Coordination.....	40
7.03	Legal Relationships.....	41
Article 8 –	Owner’s Responsibilities.....	41
8.01	Communications to Contractor.....	41
8.02	Replacement of Engineer.....	41
8.03	Furnish Data .....	41
8.04	Pay When Due .....	41
8.05	Lands and Easements; Reports and Tests.....	41
8.06	Insurance .....	42
8.07	Change Orders.....	42
8.08	Inspections, Tests, and Approvals .....	42
8.09	Limitations on Owner’s Responsibilities .....	42
8.10	Undisclosed Hazardous Environmental Condition .....	42
8.11	Evidence of Financial Arrangements .....	42
8.12	Compliance with Safety Program.....	42
Article 9 –	Engineer’s Status During Construction .....	42
9.01	Owner’s Representative.....	42
9.02	Visits to Site .....	43
9.03	Project Representative .....	43

9.04	Authorized Variations in Work .....	43
9.05	Rejecting Defective Work .....	43
9.06	Shop Drawings, Change Orders and Payments.....	44
9.07	Determinations for Unit Price Work .....	44
9.08	Decisions on Requirements of Contract Documents and Acceptability of Work.....	44
9.09	Limitations on Engineer's Authority and Responsibilities.....	45
9.10	Compliance with Safety Program.....	45
Article 10 – Changes in the Work; Claims .....		45
10.01	Authorized Changes in the Work .....	45
10.02	Unauthorized Changes in the Work .....	46
10.03	Execution of Change Orders.....	46
10.04	Notification to Surety.....	46
10.05	Claims.....	46
Article 11 – Cost of the Work; Allowances; Unit Price Work .....		47
11.01	Cost of the Work .....	47
11.02	Allowances .....	50
11.03	Unit Price Work .....	50
Article 12 – Change of Contract Price; Change of Contract Times .....		51
12.01	Change of Contract Price .....	51
12.02	Change of Contract Times .....	52
12.03	Delays.....	52
Article 13 – Tests and Inspections; Correction, Removal or Acceptance of Defective Work .....		53
13.01	Notice of Defects .....	53
13.02	Access to Work .....	53
13.03	Tests and Inspections .....	53
13.04	Uncovering Work.....	54
13.05	Owner May Stop the Work.....	55
13.06	Correction or Removal of Defective Work .....	55
13.07	Correction Period .....	55
13.08	Acceptance of Defective Work.....	56
13.09	Owner May Correct Defective Work .....	56
Article 14 – Payments to Contractor and Completion .....		57
14.01	Schedule of Values.....	57
14.02	Progress Payments .....	57
14.03	Contractor's Warranty of Title .....	60
14.04	Substantial Completion.....	60
14.05	Partial Utilization .....	61
14.06	Final Inspection.....	61
14.07	Final Payment.....	62
14.08	Final Completion Delayed.....	63
14.09	Waiver of Claims .....	63
Article 15 – Suspension of Work and Termination .....		63
15.01	Owner May Suspend Work .....	63

15.02 Owner May Terminate for Cause .....	63
15.03 Owner May Terminate For Convenience.....	65
15.04 Contractor May Stop Work or Terminate .....	65
Article 16 – Dispute Resolution .....	65
16.01 Methods and Procedures.....	65
Article 17 – Miscellaneous .....	66
17.01 Giving Notice.....	66
17.02 Computation of Times .....	66
17.03 Cumulative Remedies .....	66
17.04 Survival of Obligations .....	67
17.05 Controlling Law .....	67
17.06 Headings.....	67

## ARTICLE 1 – DEFINITIONS AND TERMINOLOGY

### 1.01 *Defined Terms*

- A. Wherever used in the Bidding Requirements or Contract Documents and printed with initial capital letters, the terms listed below will have the meanings indicated which are applicable to both the singular and plural thereof. In addition to terms specifically defined, terms with initial capital letters in the Contract Documents include references to identified articles and paragraphs, and the titles of other documents or forms.
1. *Addenda*—Written or graphic instruments issued prior to the opening of Bids which clarify, correct, or change the Bidding Requirements or the proposed Contract Documents.
  2. *Agreement*—The written instrument which is evidence of the agreement between Owner and Contractor covering the Work.
  3. *Application for Payment*—The form acceptable to Engineer which is to be used by Contractor during the course of the Work in requesting progress or final payments and which is to be accompanied by such supporting documentation as is required by the Contract Documents.
  4. *Asbestos*—Any material that contains more than one percent asbestos and is friable or is releasing asbestos fibers into the air above current action levels established by the United States Occupational Safety and Health Administration.
  5. *Bid*—The offer or proposal of a Bidder submitted on the prescribed form setting forth the prices for the Work to be performed.
  6. *Bidder*—The individual or entity who submits a Bid directly to Owner.
  7. *Bidding Documents*—The Bidding Requirements and the proposed Contract Documents (including all Addenda).
  8. *Bidding Requirements*—The advertisement or invitation to bid, Instructions to Bidders, Bid security of acceptable form, if any, and the Bid Form with any supplements.
  9. *Change Order*—A document recommended by Engineer which is signed by Contractor and Owner and authorizes an addition, deletion, or revision in the Work or an adjustment in the Contract Price or the Contract Times, issued on or after the Effective Date of the Agreement.
  10. *Claim*—A demand or assertion by Owner or Contractor seeking an adjustment of Contract Price or Contract Times, or both, or other relief with respect to the terms of the Contract. A demand for money or services by a third party is not a Claim.
  11. *Contract*—The entire and integrated written agreement between the Owner and Contractor concerning the Work. The Contract supersedes prior negotiations, representations, or agreements, whether written or oral.

12. *Contract Documents*—Those items so designated in the Agreement. Only printed or hard copies of the items listed in the Agreement are Contract Documents. Approved Shop Drawings, other Contractor submittals, and the reports and drawings of subsurface and physical conditions are not Contract Documents.
13. *Contract Price*—The moneys payable by Owner to Contractor for completion of the Work in accordance with the Contract Documents as stated in the Agreement (subject to the provisions of Paragraph 11.03 in the case of Unit Price Work).
14. *Contract Times*—The number of days or the dates stated in the Agreement to: (i) achieve Milestones, if any; (ii) achieve Substantial Completion; and (iii) complete the Work so that it is ready for final payment as evidenced by Engineer's written recommendation of final payment.
15. *Contractor*—The individual or entity with whom Owner has entered into the Agreement.
16. *Cost of the Work*—See Paragraph 11.01 for definition.
17. *Drawings*—That part of the Contract Documents prepared or approved by Engineer which graphically shows the scope, extent, and character of the Work to be performed by Contractor. Shop Drawings and other Contractor submittals are not Drawings as so defined.
18. *Effective Date of the Agreement*—The date indicated in the Agreement on which it becomes effective, but if no such date is indicated, it means the date on which the Agreement is signed and delivered by the last of the two parties to sign and deliver.
19. *Engineer*—The individual or entity named as such in the Agreement.
20. *Field Order*—A written order issued by Engineer which requires minor changes in the Work but which does not involve a change in the Contract Price or the Contract Times.
21. *General Requirements*—Sections of Division 1 of the Specifications.
22. *Hazardous Environmental Condition*—The presence at the Site of Asbestos, PCBs, Petroleum, Hazardous Waste, or Radioactive Material in such quantities or circumstances that may present a substantial danger to persons or property exposed thereto.
23. *Hazardous Waste*—The term Hazardous Waste shall have the meaning provided in Section 1004 of the Solid Waste Disposal Act (42 USC Section 6903) as amended from time to time.
24. *Laws and Regulations; Laws or Regulations*—Any and all applicable laws, rules, regulations, ordinances, codes, and orders of any and all governmental bodies, agencies, authorities, and courts having jurisdiction.
25. *Liens*—Charges, security interests, or encumbrances upon Project funds, real property, or personal property.
26. *Milestone*—A principal event specified in the Contract Documents relating to an intermediate completion date or time prior to Substantial Completion of all the Work.

27. *Notice of Award*—The written notice by Owner to the Successful Bidder stating that upon timely compliance by the Successful Bidder with the conditions precedent listed therein, Owner will sign and deliver the Agreement.
28. *Notice to Proceed*—A written notice given by Owner to Contractor fixing the date on which the Contract Times will commence to run and on which Contractor shall start to perform the Work under the Contract Documents.
29. *Owner*—The individual or entity with whom Contractor has entered into the Agreement and for whom the Work is to be performed.
30. *PCBs*—Polychlorinated biphenyls.
31. *Petroleum*—Petroleum, including crude oil or any fraction thereof which is liquid at standard conditions of temperature and pressure (60 degrees Fahrenheit and 14.7 pounds per square inch absolute), such as oil, petroleum, fuel oil, oil sludge, oil refuse, gasoline, kerosene, and oil mixed with other non-Hazardous Waste and crude oils.
32. *Progress Schedule*—A schedule, prepared and maintained by Contractor, describing the sequence and duration of the activities comprising the Contractor's plan to accomplish the Work within the Contract Times.
33. *Project*—The total construction of which the Work to be performed under the Contract Documents may be the whole, or a part.
34. *Project Manual*—The bound documentary information prepared for bidding and constructing the Work. A listing of the contents of the Project Manual, which may be bound in one or more volumes, is contained in the table(s) of contents.
35. *Radioactive Material*—Source, special nuclear, or byproduct material as defined by the Atomic Energy Act of 1954 (42 USC Section 2011 et seq.) as amended from time to time.
36. *Resident Project Representative*—The authorized representative of Engineer who may be assigned to the Site or any part thereof.
37. *Samples*—Physical examples of materials, equipment, or workmanship that are representative of some portion of the Work and which establish the standards by which such portion of the Work will be judged.
38. *Schedule of Submittals*—A schedule, prepared and maintained by Contractor, of required submittals and the time requirements to support scheduled performance of related construction activities.
39. *Schedule of Values*—A schedule, prepared and maintained by Contractor, allocating portions of the Contract Price to various portions of the Work and used as the basis for reviewing Contractor's Applications for Payment.
40. *Shop Drawings*—All drawings, diagrams, illustrations, schedules, and other data or information which are specifically prepared or assembled by or for Contractor and submitted by Contractor to illustrate some portion of the Work.

41. *Site*—Lands or areas indicated in the Contract Documents as being furnished by Owner upon which the Work is to be performed, including rights-of-way and easements for access thereto, and such other lands furnished by Owner which are designated for the use of Contractor.
42. *Specifications*—That part of the Contract Documents consisting of written requirements for materials, equipment, systems, standards and workmanship as applied to the Work, and certain administrative requirements and procedural matters applicable thereto.
43. *Subcontractor*—An individual or entity having a direct contract with Contractor or with any other Subcontractor for the performance of a part of the Work at the Site.
44. *Substantial Completion*—The time at which the Work (or a specified part thereof) has progressed to the point where, in the opinion of Engineer, the Work (or a specified part thereof) is sufficiently complete, in accordance with the Contract Documents, so that the Work (or a specified part thereof) can be utilized for the purposes for which it is intended. The terms “substantially complete” and “substantially completed” as applied to all or part of the Work refer to Substantial Completion thereof.
45. *Successful Bidder*—The Bidder submitting a responsive Bid to whom Owner makes an award.
46. *Supplementary Conditions*—That part of the Contract Documents which amends or supplements these General Conditions.
47. *Supplier*—A manufacturer, fabricator, supplier, distributor, materialman, or vendor having a direct contract with Contractor or with any Subcontractor to furnish materials or equipment to be incorporated in the Work by Contractor or Subcontractor.
48. *Underground Facilities*—All underground pipelines, conduits, ducts, cables, wires, manholes, vaults, tanks, tunnels, or other such facilities or attachments, and any encasements containing such facilities, including those that convey electricity, gases, steam, liquid petroleum products, telephone or other communications, cable television, water, wastewater, storm water, other liquids or chemicals, or traffic or other control systems.
49. *Unit Price Work*—Work to be paid for on the basis of unit prices.
50. *Work*—The entire construction or the various separately identifiable parts thereof required to be provided under the Contract Documents. Work includes and is the result of performing or providing all labor, services, and documentation necessary to produce such construction, and furnishing, installing, and incorporating all materials and equipment into such construction, all as required by the Contract Documents.
51. *Work Change Directive*—A written statement to Contractor issued on or after the Effective Date of the Agreement and signed by Owner and recommended by Engineer ordering an addition, deletion, or revision in the Work, or responding to differing or unforeseen subsurface or physical conditions under which the Work is to be performed or to emergencies. A Work Change Directive will not change the Contract Price or the Contract Times but is evidence that the parties expect that the change ordered or documented by a

Work Change Directive will be incorporated in a subsequently issued Change Order following negotiations by the parties as to its effect, if any, on the Contract Price or Contract Times.

## 1.02 Terminology

A. The words and terms discussed in Paragraph 1.02.B through F are not defined but, when used in the Bidding Requirements or Contract Documents, have the indicated meaning.

### B. *Intent of Certain Terms or Adjectives:*

1. The Contract Documents include the terms “as allowed,” “as approved,” “as ordered,” “as directed” or terms of like effect or import to authorize an exercise of professional judgment by Engineer. In addition, the adjectives “reasonable,” “suitable,” “acceptable,” “proper,” “satisfactory,” or adjectives of like effect or import are used to describe an action or determination of Engineer as to the Work. It is intended that such exercise of professional judgment, action, or determination will be solely to evaluate, in general, the Work for compliance with the information in the Contract Documents and with the design concept of the Project as a functioning whole as shown or indicated in the Contract Documents (unless there is a specific statement indicating otherwise). The use of any such term or adjective is not intended to and shall not be effective to assign to Engineer any duty or authority to supervise or direct the performance of the Work, or any duty or authority to undertake responsibility contrary to the provisions of Paragraph 9.09 or any other provision of the Contract Documents.

### C. *Day:*

1. The word “day” means a calendar day of 24 hours measured from midnight to the next midnight.

### D. *Defective:*

1. The word “defective,” when modifying the word “Work,” refers to Work that is unsatisfactory, faulty, or deficient in that it:
  - a. does not conform to the Contract Documents; or
  - b. does not meet the requirements of any applicable inspection, reference standard, test, or approval referred to in the Contract Documents; or
  - c. has been damaged prior to Engineer’s recommendation of final payment (unless responsibility for the protection thereof has been assumed by Owner at Substantial Completion in accordance with Paragraph 14.04 or 14.05).

### E. *Furnish, Install, Perform, Provide:*

1. The word “furnish,” when used in connection with services, materials, or equipment, shall mean to supply and deliver said services, materials, or equipment to the Site (or some other specified location) ready for use or installation and in usable or operable condition.

2. The word "install," when used in connection with services, materials, or equipment, shall mean to put into use or place in final position said services, materials, or equipment complete and ready for intended use.
3. The words "perform" or "provide," when used in connection with services, materials, or equipment, shall mean to furnish and install said services, materials, or equipment complete and ready for intended use.
4. When "furnish," "install," "perform," or "provide" is not used in connection with services, materials, or equipment in a context clearly requiring an obligation of Contractor, "provide" is implied.

F. Unless stated otherwise in the Contract Documents, words or phrases that have a well-known technical or construction industry or trade meaning are used in the Contract Documents in accordance with such recognized meaning.

## ARTICLE 2 – PRELIMINARY MATTERS

### 2.01 *Delivery of Bonds and Evidence of Insurance*

- A. When Contractor delivers the executed counterparts of the Agreement to Owner, Contractor shall also deliver to Owner such bonds as Contractor may be required to furnish.
- B. *Evidence of Insurance:* Before any Work at the Site is started, Contractor and Owner shall each deliver to the other, with copies to each additional insured identified in the Supplementary Conditions, certificates of insurance (and other evidence of insurance which either of them or any additional insured may reasonably request) which Contractor and Owner respectively are required to purchase and maintain in accordance with Article 5.

### 2.02 *Copies of Documents*

- A. Owner shall furnish to Contractor up to ten printed or hard copies of the Drawings and Project Manual. Additional copies will be furnished upon request at the cost of reproduction.

### 2.03 *Commencement of Contract Times; Notice to Proceed*

- A. The Contract Times will commence to run on the thirtieth day after the Effective Date of the Agreement or, if a Notice to Proceed is given, on the day indicated in the Notice to Proceed. A Notice to Proceed may be given at any time within 30 days after the Effective Date of the Agreement. In no event will the Contract Times commence to run later than the sixtieth day after the day of Bid opening or the thirtieth day after the Effective Date of the Agreement, whichever date is earlier.

### 2.04 *Starting the Work*

- A. Contractor shall start to perform the Work on the date when the Contract Times commence to run. No Work shall be done at the Site prior to the date on which the Contract Times commence to run.

2.05 *Before Starting Construction*

A. *Preliminary Schedules:* Within 10 days after the Effective Date of the Agreement (unless otherwise specified in the General Requirements), Contractor shall submit to Engineer for timely review:

1. a preliminary Progress Schedule indicating the times (numbers of days or dates) for starting and completing the various stages of the Work, including any Milestones specified in the Contract Documents;
2. a preliminary Schedule of Submittals; and
3. a preliminary Schedule of Values for all of the Work which includes quantities and prices of items which when added together equal the Contract Price and subdivides the Work into component parts in sufficient detail to serve as the basis for progress payments during performance of the Work. Such prices will include an appropriate amount of overhead and profit applicable to each item of Work.

2.06 *Preconstruction Conference; Designation of Authorized Representatives*

A. Before any Work at the Site is started, a conference attended by Owner, Contractor, Engineer, and others as appropriate will be held to establish a working understanding among the parties as to the Work and to discuss the schedules referred to in Paragraph 2.05.A, procedures for handling Shop Drawings and other submittals, processing Applications for Payment, and maintaining required records.

B. At this conference Owner and Contractor each shall designate, in writing, a specific individual to act as its authorized representative with respect to the services and responsibilities under the Contract. Such individuals shall have the authority to transmit instructions, receive information, render decisions relative to the Contract, and otherwise act on behalf of each respective party.

2.07 *Initial Acceptance of Schedules*

A. At least 10 days before submission of the first Application for Payment a conference attended by Contractor, Engineer, and others as appropriate will be held to review for acceptability to Engineer as provided below the schedules submitted in accordance with Paragraph 2.05.A. Contractor shall have an additional 10 days to make corrections and adjustments and to complete and resubmit the schedules. No progress payment shall be made to Contractor until acceptable schedules are submitted to Engineer.

1. The Progress Schedule will be acceptable to Engineer if it provides an orderly progression of the Work to completion within the Contract Times. Such acceptance will not impose on Engineer responsibility for the Progress Schedule, for sequencing, scheduling, or progress of the Work, nor interfere with or relieve Contractor from Contractor's full responsibility therefor.
2. Contractor's Schedule of Submittals will be acceptable to Engineer if it provides a workable arrangement for reviewing and processing the required submittals.

3. Contractor's Schedule of Values will be acceptable to Engineer as to form and substance if it provides a reasonable allocation of the Contract Price to component parts of the Work.

### ARTICLE 3 – CONTRACT DOCUMENTS: INTENT, AMENDING, REUSE

#### 3.01 *Intent*

- A. The Contract Documents are complementary; what is required by one is as binding as if required by all.
- B. It is the intent of the Contract Documents to describe a functionally complete project (or part thereof) to be constructed in accordance with the Contract Documents. Any labor, documentation, services, materials, or equipment that reasonably may be inferred from the Contract Documents or from prevailing custom or trade usage as being required to produce the indicated result will be provided whether or not specifically called for, at no additional cost to Owner.
- C. Clarifications and interpretations of the Contract Documents shall be issued by Engineer as provided in Article 9.

#### 3.02 *Reference Standards*

- A. Standards, Specifications, Codes, Laws, and Regulations
  1. Reference to standards, specifications, manuals, or codes of any technical society, organization, or association, or to Laws or Regulations, whether such reference be specific or by implication, shall mean the standard, specification, manual, code, or Laws or Regulations in effect at the time of opening of Bids (or on the Effective Date of the Agreement if there were no Bids), except as may be otherwise specifically stated in the Contract Documents.
  2. No provision of any such standard, specification, manual, or code, or any instruction of a Supplier, shall be effective to change the duties or responsibilities of Owner, Contractor, or Engineer, or any of their subcontractors, consultants, agents, or employees, from those set forth in the Contract Documents. No such provision or instruction shall be effective to assign to Owner, Engineer, or any of their officers, directors, members, partners, employees, agents, consultants, or subcontractors, any duty or authority to supervise or direct the performance of the Work or any duty or authority to undertake responsibility inconsistent with the provisions of the Contract Documents.

#### 3.03 *Reporting and Resolving Discrepancies*

##### A. *Reporting Discrepancies:*

1. *Contractor's Review of Contract Documents Before Starting Work:* Before undertaking each part of the Work, Contractor shall carefully study and compare the Contract Documents and check and verify pertinent figures therein and all applicable field measurements. Contractor shall promptly report in writing to Engineer any conflict, error, ambiguity, or discrepancy which Contractor discovers, or has actual knowledge of, and shall obtain a written interpretation or clarification from Engineer before proceeding with any Work affected thereby.

2. *Contractor's Review of Contract Documents During Performance of Work:* If, during the performance of the Work, Contractor discovers any conflict, error, ambiguity, or discrepancy within the Contract Documents, or between the Contract Documents and (a) any applicable Law or Regulation, (b) any standard, specification, manual, or code, or (c) any instruction of any Supplier, then Contractor shall promptly report it to Engineer in writing. Contractor shall not proceed with the Work affected thereby (except in an emergency as required by Paragraph 6.16.A) until an amendment or supplement to the Contract Documents has been issued by one of the methods indicated in Paragraph 3.04.
3. Contractor shall not be liable to Owner or Engineer for failure to report any conflict, error, ambiguity, or discrepancy in the Contract Documents unless Contractor had actual knowledge thereof.

B. *Resolving Discrepancies:*

1. Except as may be otherwise specifically stated in the Contract Documents, the provisions of the Contract Documents shall take precedence in resolving any conflict, error, ambiguity, or discrepancy between the provisions of the Contract Documents and:
  - a. the provisions of any standard, specification, manual, or code, or the instruction of any Supplier (whether or not specifically incorporated by reference in the Contract Documents); or
  - b. the provisions of any Laws or Regulations applicable to the performance of the Work (unless such an interpretation of the provisions of the Contract Documents would result in violation of such Law or Regulation).

3.04 *Amending and Supplementing Contract Documents*

- A. The Contract Documents may be amended to provide for additions, deletions, and revisions in the Work or to modify the terms and conditions thereof by either a Change Order or a Work Change Directive.
- B. The requirements of the Contract Documents may be supplemented, and minor variations and deviations in the Work may be authorized, by one or more of the following ways:
  1. A Field Order;
  2. Engineer's approval of a Shop Drawing or Sample (subject to the provisions of Paragraph 6.17.D.3); or
  3. Engineer's written interpretation or clarification.

3.05 *Reuse of Documents*

- A. Contractor and any Subcontractor or Supplier shall not:
  1. have or acquire any title to or ownership rights in any of the Drawings, Specifications, or other documents (or copies of any thereof) prepared by or bearing the seal of Engineer or its consultants, including electronic media editions; or

2. reuse any such Drawings, Specifications, other documents, or copies thereof on extensions of the Project or any other project without written consent of Owner and Engineer and specific written verification or adaptation by Engineer.
- B. The prohibitions of this Paragraph 3.05 will survive final payment, or termination of the Contract. Nothing herein shall preclude Contractor from retaining copies of the Contract Documents for record purposes.

### 3.06 *Electronic Data*

- A. Unless otherwise stated in the Supplementary Conditions, the data furnished by Owner or Engineer to Contractor, or by Contractor to Owner or Engineer, that may be relied upon are limited to the printed copies (also known as hard copies). Files in electronic media format of text, data, graphics, or other types are furnished only for the convenience of the receiving party. Any conclusion or information obtained or derived from such electronic files will be at the user's sole risk. If there is a discrepancy between the electronic files and the hard copies, the hard copies govern.
- B. Because data stored in electronic media format can deteriorate or be modified inadvertently or otherwise without authorization of the data's creator, the party receiving electronic files agrees that it will perform acceptance tests or procedures within 60 days, after which the receiving party shall be deemed to have accepted the data thus transferred. Any errors detected within the 60-day acceptance period will be corrected by the transferring party.
- C. When transferring documents in electronic media format, the transferring party makes no representations as to long term compatibility, usability, or readability of documents resulting from the use of software application packages, operating systems, or computer hardware differing from those used by the data's creator.

## **ARTICLE 4 – AVAILABILITY OF LANDS; SUBSURFACE AND PHYSICAL CONDITIONS; HAZARDOUS ENVIRONMENTAL CONDITIONS; REFERENCE POINTS**

### 4.01 *Availability of Lands*

- A. Owner shall furnish the Site. Owner shall notify Contractor of any encumbrances or restrictions not of general application but specifically related to use of the Site with which Contractor must comply in performing the Work. Owner will obtain in a timely manner and pay for easements for permanent structures or permanent changes in existing facilities. If Contractor and Owner are unable to agree on entitlement to or on the amount or extent, if any, of any adjustment in the Contract Price or Contract Times, or both, as a result of any delay in Owner's furnishing the Site or a part thereof, Contractor may make a Claim therefor as provided in Paragraph 10.05.
- B. Upon reasonable written request, Owner shall furnish Contractor with a current statement of record legal title and legal description of the lands upon which the Work is to be performed and Owner's interest therein as necessary for giving notice of or filing a mechanic's or construction lien against such lands in accordance with applicable Laws and Regulations.
- C. Contractor shall provide for all additional lands and access thereto that may be required for temporary construction facilities or storage of materials and equipment.

#### 4.02 *Subsurface and Physical Conditions*

A. *Reports and Drawings:* The Supplementary Conditions identify:

1. those reports known to Owner of explorations and tests of subsurface conditions at or contiguous to the Site; and
2. those drawings known to Owner of physical conditions relating to existing surface or subsurface structures at the Site (except Underground Facilities).

B. *Limited Reliance by Contractor on Technical Data Authorized:* Contractor may rely upon the accuracy of the “technical data” contained in such reports and drawings, but such reports and drawings are not Contract Documents. Such “technical data” is identified in the Supplementary Conditions. Except for such reliance on such “technical data,” Contractor may not rely upon or make any claim against Owner or Engineer, or any of their officers, directors, members, partners, employees, agents, consultants, or subcontractors with respect to:

1. the completeness of such reports and drawings for Contractor’s purposes, including, but not limited to, any aspects of the means, methods, techniques, sequences, and procedures of construction to be employed by Contractor, and safety precautions and programs incident thereto; or
2. other data, interpretations, opinions, and information contained in such reports or shown or indicated in such drawings; or
3. any Contractor interpretation of or conclusion drawn from any “technical data” or any such other data, interpretations, opinions, or information.

#### 4.03 *Differing Subsurface or Physical Conditions*

A. *Notice:* If Contractor believes that any subsurface or physical condition that is uncovered or revealed either:

1. is of such a nature as to establish that any “technical data” on which Contractor is entitled to rely as provided in Paragraph 4.02 is materially inaccurate; or
2. is of such a nature as to require a change in the Contract Documents; or
3. differs materially from that shown or indicated in the Contract Documents; or
4. is of an unusual nature, and differs materially from conditions ordinarily encountered and generally recognized as inherent in work of the character provided for in the Contract Documents;

then Contractor shall, promptly after becoming aware thereof and before further disturbing the subsurface or physical conditions or performing any Work in connection therewith (except in an emergency as required by Paragraph 6.16.A), notify Owner and Engineer in writing about such condition. Contractor shall not further disturb such condition or perform any Work in connection therewith (except as aforesaid) until receipt of written order to do so.

B. *Engineer's Review:* After receipt of written notice as required by Paragraph 4.03.A, Engineer will promptly review the pertinent condition, determine the necessity of Owner's obtaining additional exploration or tests with respect thereto, and advise Owner in writing (with a copy to Contractor) of Engineer's findings and conclusions.

C. *Possible Price and Times Adjustments:*

1. The Contract Price or the Contract Times, or both, will be equitably adjusted to the extent that the existence of such differing subsurface or physical condition causes an increase or decrease in Contractor's cost of, or time required for, performance of the Work; subject, however, to the following:
  - a. such condition must meet any one or more of the categories described in Paragraph 4.03.A; and
  - b. with respect to Work that is paid for on a unit price basis, any adjustment in Contract Price will be subject to the provisions of Paragraphs 9.07 and 11.03.
2. Contractor shall not be entitled to any adjustment in the Contract Price or Contract Times if:
  - a. Contractor knew of the existence of such conditions at the time Contractor made a final commitment to Owner with respect to Contract Price and Contract Times by the submission of a Bid or becoming bound under a negotiated contract; or
  - b. the existence of such condition could reasonably have been discovered or revealed as a result of any examination, investigation, exploration, test, or study of the Site and contiguous areas required by the Bidding Requirements or Contract Documents to be conducted by or for Contractor prior to Contractor's making such final commitment; or
  - c. Contractor failed to give the written notice as required by Paragraph 4.03.A.
3. If Owner and Contractor are unable to agree on entitlement to or on the amount or extent, if any, of any adjustment in the Contract Price or Contract Times, or both, a Claim may be made therefor as provided in Paragraph 10.05. However, neither Owner or Engineer, or any of their officers, directors, members, partners, employees, agents, consultants, or subcontractors shall be liable to Contractor for any claims, costs, losses, or damages (including but not limited to all fees and charges of engineers, architects, attorneys, and other professionals and all court or arbitration or other dispute resolution costs) sustained by Contractor on or in connection with any other project or anticipated project.

#### 4.04 *Underground Facilities*

A. *Shown or Indicated:* The information and data shown or indicated in the Contract Documents with respect to existing Underground Facilities at or contiguous to the Site is based on information and data furnished to Owner or Engineer by the owners of such Underground Facilities, including Owner, or by others. Unless it is otherwise expressly provided in the Supplementary Conditions:

1. Owner and Engineer shall not be responsible for the accuracy or completeness of any such information or data provided by others; and

2. the cost of all of the following will be included in the Contract Price, and Contractor shall have full responsibility for:
  - a. reviewing and checking all such information and data;
  - b. locating all Underground Facilities shown or indicated in the Contract Documents;
  - c. coordination of the Work with the owners of such Underground Facilities, including Owner, during construction; and
  - d. the safety and protection of all such Underground Facilities and repairing any damage thereto resulting from the Work.

B. *Not Shown or Indicated:*

1. If an Underground Facility is uncovered or revealed at or contiguous to the Site which was not shown or indicated, or not shown or indicated with reasonable accuracy in the Contract Documents, Contractor shall, promptly after becoming aware thereof and before further disturbing conditions affected thereby or performing any Work in connection therewith (except in an emergency as required by Paragraph 6.16.A), identify the owner of such Underground Facility and give written notice to that owner and to Owner and Engineer. Engineer will promptly review the Underground Facility and determine the extent, if any, to which a change is required in the Contract Documents to reflect and document the consequences of the existence or location of the Underground Facility. During such time, Contractor shall be responsible for the safety and protection of such Underground Facility.
2. If Engineer concludes that a change in the Contract Documents is required, a Work Change Directive or a Change Order will be issued to reflect and document such consequences. An equitable adjustment shall be made in the Contract Price or Contract Times, or both, to the extent that they are attributable to the existence or location of any Underground Facility that was not shown or indicated or not shown or indicated with reasonable accuracy in the Contract Documents and that Contractor did not know of and could not reasonably have been expected to be aware of or to have anticipated. If Owner and Contractor are unable to agree on entitlement to or on the amount or extent, if any, of any such adjustment in Contract Price or Contract Times, Owner or Contractor may make a Claim therefor as provided in Paragraph 10.05.

4.05 *Reference Points*

- A. Owner shall provide engineering surveys to establish reference points for construction which in Engineer's judgment are necessary to enable Contractor to proceed with the Work. Contractor shall be responsible for laying out the Work, shall protect and preserve the established reference points and property monuments, and shall make no changes or relocations without the prior written approval of Owner. Contractor shall report to Engineer whenever any reference point or property monument is lost or destroyed or requires relocation because of necessary changes in grades or locations, and shall be responsible for the accurate replacement or relocation of such reference points or property monuments by professionally qualified personnel.

#### 4.06 *Hazardous Environmental Condition at Site*

- A. *Reports and Drawings:* The Supplementary Conditions identify those reports and drawings known to Owner relating to Hazardous Environmental Conditions that have been identified at the Site.
- B. *Limited Reliance by Contractor on Technical Data Authorized:* Contractor may rely upon the accuracy of the “technical data” contained in such reports and drawings, but such reports and drawings are not Contract Documents. Such “technical data” is identified in the Supplementary Conditions. Except for such reliance on such “technical data,” Contractor may not rely upon or make any claim against Owner or Engineer, or any of their officers, directors, members, partners, employees, agents, consultants, or subcontractors with respect to:
1. the completeness of such reports and drawings for Contractor’s purposes, including, but not limited to, any aspects of the means, methods, techniques, sequences and procedures of construction to be employed by Contractor and safety precautions and programs incident thereto; or
  2. other data, interpretations, opinions and information contained in such reports or shown or indicated in such drawings; or
  3. any Contractor interpretation of or conclusion drawn from any “technical data” or any such other data, interpretations, opinions or information.
- C. Contractor shall not be responsible for any Hazardous Environmental Condition uncovered or revealed at the Site which was not shown or indicated in Drawings or Specifications or identified in the Contract Documents to be within the scope of the Work. Contractor shall be responsible for a Hazardous Environmental Condition created with any materials brought to the Site by Contractor, Subcontractors, Suppliers, or anyone else for whom Contractor is responsible.
- D. If Contractor encounters a Hazardous Environmental Condition or if Contractor or anyone for whom Contractor is responsible creates a Hazardous Environmental Condition, Contractor shall immediately: (i) secure or otherwise isolate such condition; (ii) stop all Work in connection with such condition and in any area affected thereby (except in an emergency as required by Paragraph 6.16.A); and (iii) notify Owner and Engineer (and promptly thereafter confirm such notice in writing). Owner shall promptly consult with Engineer concerning the necessity for Owner to retain a qualified expert to evaluate such condition or take corrective action, if any. Promptly after consulting with Engineer, Owner shall take such actions as are necessary to permit Owner to timely obtain required permits and provide Contractor the written notice required by Paragraph 4.06.E.
- E. Contractor shall not be required to resume Work in connection with such condition or in any affected area until after Owner has obtained any required permits related thereto and delivered written notice to Contractor: (i) specifying that such condition and any affected area is or has been rendered safe for the resumption of Work; or (ii) specifying any special conditions under which such Work may be resumed safely. If Owner and Contractor cannot agree as to entitlement to or on the amount or extent, if any, of any adjustment in Contract Price or Contract Times, or both, as a result of such Work stoppage or such special conditions under which Work

is agreed to be resumed by Contractor, either party may make a Claim therefor as provided in Paragraph 10.05.

- F. If after receipt of such written notice Contractor does not agree to resume such Work based on a reasonable belief it is unsafe, or does not agree to resume such Work under such special conditions, then Owner may order the portion of the Work that is in the area affected by such condition to be deleted from the Work. If Owner and Contractor cannot agree as to entitlement to or on the amount or extent, if any, of an adjustment in Contract Price or Contract Times as a result of deleting such portion of the Work, then either party may make a Claim therefor as provided in Paragraph 10.05. Owner may have such deleted portion of the Work performed by Owner's own forces or others in accordance with Article 7.
- G. To the fullest extent permitted by Laws and Regulations, Owner shall indemnify and hold harmless Contractor, Subcontractors, and Engineer, and the officers, directors, members, partners, employees, agents, consultants, and subcontractors of each and any of them from and against all claims, costs, losses, and damages (including but not limited to all fees and charges of engineers, architects, attorneys, and other professionals and all court or arbitration or other dispute resolution costs) arising out of or relating to a Hazardous Environmental Condition, provided that such Hazardous Environmental Condition: (i) was not shown or indicated in the Drawings or Specifications or identified in the Contract Documents to be included within the scope of the Work, and (ii) was not created by Contractor or by anyone for whom Contractor is responsible. Nothing in this Paragraph 4.06.G shall obligate Owner to indemnify any individual or entity from and against the consequences of that individual's or entity's own negligence.
- H. To the fullest extent permitted by Laws and Regulations, Contractor shall indemnify and hold harmless Owner and Engineer, and the officers, directors, members, partners, employees, agents, consultants, and subcontractors of each and any of them from and against all claims, costs, losses, and damages (including but not limited to all fees and charges of engineers, architects, attorneys, and other professionals and all court or arbitration or other dispute resolution costs) arising out of or relating to a Hazardous Environmental Condition created by Contractor or by anyone for whom Contractor is responsible. Nothing in this Paragraph 4.06.H shall obligate Contractor to indemnify any individual or entity from and against the consequences of that individual's or entity's own negligence.
- I. The provisions of Paragraphs 4.02, 4.03, and 4.04 do not apply to a Hazardous Environmental Condition uncovered or revealed at the Site.

## **ARTICLE 5 – BONDS AND INSURANCE**

### **5.01 *Performance, Payment, and Other Bonds***

- A. Contractor shall furnish performance and payment bonds, each in an amount at least equal to the Contract Price as security for the faithful performance and payment of all of Contractor's obligations under the Contract Documents. These bonds shall remain in effect until one year after the date when final payment becomes due or until completion of the correction period specified in Paragraph 13.07, whichever is later, except as provided otherwise by Laws or Regulations or by the Contract Documents. Contractor shall also furnish such other bonds as are required by the Contract Documents.

- B. All bonds shall be in the form prescribed by the Contract Documents except as provided otherwise by Laws or Regulations, and shall be executed by such sureties as are named in the list of "Companies Holding Certificates of Authority as Acceptable Sureties on Federal Bonds and as Acceptable Reinsuring Companies" as published in Circular 570 (amended) by the Financial Management Service, Surety Bond Branch, U.S. Department of the Treasury. All bonds signed by an agent or attorney-in-fact must be accompanied by a certified copy of that individual's authority to bind the surety. The evidence of authority shall show that it is effective on the date the agent or attorney-in-fact signed each bond.
- C. If the surety on any bond furnished by Contractor is declared bankrupt or becomes insolvent or its right to do business is terminated in any state where any part of the Project is located or it ceases to meet the requirements of Paragraph 5.01.B, Contractor shall promptly notify Owner and Engineer and shall, within 20 days after the event giving rise to such notification, provide another bond and surety, both of which shall comply with the requirements of Paragraphs 5.01.B and 5.02.

#### 5.02 *Licensed Sureties and Insurers*

- A. All bonds and insurance required by the Contract Documents to be purchased and maintained by Owner or Contractor shall be obtained from surety or insurance companies that are duly licensed or authorized in the jurisdiction in which the Project is located to issue bonds or insurance policies for the limits and coverages so required. Such surety and insurance companies shall also meet such additional requirements and qualifications as may be provided in the Supplementary Conditions.

#### 5.03 *Certificates of Insurance*

- A. Contractor shall deliver to Owner, with copies to each additional insured and loss payee identified in the Supplementary Conditions, certificates of insurance (and other evidence of insurance requested by Owner or any other additional insured) which Contractor is required to purchase and maintain.
- B. Owner shall deliver to Contractor, with copies to each additional insured and loss payee identified in the Supplementary Conditions, certificates of insurance (and other evidence of insurance requested by Contractor or any other additional insured) which Owner is required to purchase and maintain.
- C. Failure of Owner to demand such certificates or other evidence of Contractor's full compliance with these insurance requirements or failure of Owner to identify a deficiency in compliance from the evidence provided shall not be construed as a waiver of Contractor's obligation to maintain such insurance.
- D. Owner does not represent that insurance coverage and limits established in this Contract necessarily will be adequate to protect Contractor.
- E. The insurance and insurance limits required herein shall not be deemed as a limitation on Contractor's liability under the indemnities granted to Owner in the Contract Documents.

#### 5.04 *Contractor's Insurance*

- A. Contractor shall purchase and maintain such insurance as is appropriate for the Work being performed and as will provide protection from claims set forth below which may arise out of or result from Contractor's performance of the Work and Contractor's other obligations under the Contract Documents, whether it is to be performed by Contractor, any Subcontractor or Supplier, or by anyone directly or indirectly employed by any of them to perform any of the Work, or by anyone for whose acts any of them may be liable:
1. claims under workers' compensation, disability benefits, and other similar employee benefit acts;
  2. claims for damages because of bodily injury, occupational sickness or disease, or death of Contractor's employees;
  3. claims for damages because of bodily injury, sickness or disease, or death of any person other than Contractor's employees;
  4. claims for damages insured by reasonably available personal injury liability coverage which are sustained:
    - a. by any person as a result of an offense directly or indirectly related to the employment of such person by Contractor, or
    - b. by any other person for any other reason;
  5. claims for damages, other than to the Work itself, because of injury to or destruction of tangible property wherever located, including loss of use resulting therefrom; and
  6. claims for damages because of bodily injury or death of any person or property damage arising out of the ownership, maintenance or use of any motor vehicle.
- B. The policies of insurance required by this Paragraph 5.04 shall:
1. with respect to insurance required by Paragraphs 5.04.A.3 through 5.04.A.6 inclusive, be written on an occurrence basis, include as additional insureds (subject to any customary exclusion regarding professional liability) Owner and Engineer, and any other individuals or entities identified in the Supplementary Conditions, all of whom shall be listed as additional insureds, and include coverage for the respective officers, directors, members, partners, employees, agents, consultants, and subcontractors of each and any of all such additional insureds, and the insurance afforded to these additional insureds shall provide primary coverage for all claims covered thereby;
  2. include at least the specific coverages and be written for not less than the limits of liability provided in the Supplementary Conditions or required by Laws or Regulations, whichever is greater;
  3. include contractual liability insurance covering Contractor's indemnity obligations under Paragraphs 6.11 and 6.20;

4. contain a provision or endorsement that the coverage afforded will not be canceled, materially changed or renewal refused until at least 30 days prior written notice has been given to Owner and Contractor and to each other additional insured identified in the Supplementary Conditions to whom a certificate of insurance has been issued (and the certificates of insurance furnished by the Contractor pursuant to Paragraph 5.03 will so provide);
5. remain in effect at least until final payment and at all times thereafter when Contractor may be correcting, removing, or replacing defective Work in accordance with Paragraph 13.07; and
6. include completed operations coverage:
  - a. Such insurance shall remain in effect for two years after final payment.
  - b. Contractor shall furnish Owner and each other additional insured identified in the Supplementary Conditions, to whom a certificate of insurance has been issued, evidence satisfactory to Owner and any such additional insured of continuation of such insurance at final payment and one year thereafter.

#### 5.05 *Owner's Liability Insurance*

- A. In addition to the insurance required to be provided by Contractor under Paragraph 5.04, Owner, at Owner's option, may purchase and maintain at Owner's expense Owner's own liability insurance as will protect Owner against claims which may arise from operations under the Contract Documents.

#### 5.06 *Property Insurance*

- A. Unless otherwise provided in the Supplementary Conditions, Owner shall purchase and maintain property insurance upon the Work at the Site in the amount of the full replacement cost thereof (subject to such deductible amounts as may be provided in the Supplementary Conditions or required by Laws and Regulations). This insurance shall:
  1. include the interests of Owner, Contractor, Subcontractors, and Engineer, and any other individuals or entities identified in the Supplementary Conditions, and the officers, directors, members, partners, employees, agents, consultants, and subcontractors of each and any of them, each of whom is deemed to have an insurable interest and shall be listed as a loss payee;
  2. be written on a Builder's Risk "all-risk" policy form that shall at least include insurance for physical loss or damage to the Work, temporary buildings, falsework, and materials and equipment in transit, and shall insure against at least the following perils or causes of loss: fire, lightning, extended coverage, theft, vandalism and malicious mischief, earthquake, collapse, debris removal, demolition occasioned by enforcement of Laws and Regulations, water damage (other than that caused by flood), and such other perils or causes of loss as may be specifically required by the Supplementary Conditions.

3. include expenses incurred in the repair or replacement of any insured property (including but not limited to fees and charges of engineers and architects);
  4. cover materials and equipment stored at the Site or at another location that was agreed to in writing by Owner prior to being incorporated in the Work, provided that such materials and equipment have been included in an Application for Payment recommended by Engineer;
  5. allow for partial utilization of the Work by Owner;
  6. include testing and startup; and
  7. be maintained in effect until final payment is made unless otherwise agreed to in writing by Owner, Contractor, and Engineer with 30 days written notice to each other loss payee to whom a certificate of insurance has been issued.
- B. Owner shall purchase and maintain such equipment breakdown insurance or additional property insurance as may be required by the Supplementary Conditions or Laws and Regulations which will include the interests of Owner, Contractor, Subcontractors, and Engineer, and any other individuals or entities identified in the Supplementary Conditions, and the officers, directors, members, partners, employees, agents, consultants and subcontractors of each and any of them, each of whom is deemed to have an insurable interest and shall be listed as a loss payee.
- C. All the policies of insurance (and the certificates or other evidence thereof) required to be purchased and maintained in accordance with this Paragraph 5.06 will contain a provision or endorsement that the coverage afforded will not be canceled or materially changed or renewal refused until at least 30 days prior written notice has been given to Owner and Contractor and to each other loss payee to whom a certificate of insurance has been issued and will contain waiver provisions in accordance with Paragraph 5.07.
- D. Owner shall not be responsible for purchasing and maintaining any property insurance specified in this Paragraph 5.06 to protect the interests of Contractor, Subcontractors, or others in the Work to the extent of any deductible amounts that are identified in the Supplementary Conditions. The risk of loss within such identified deductible amount will be borne by Contractor, Subcontractors, or others suffering any such loss, and if any of them wishes property insurance coverage within the limits of such amounts, each may purchase and maintain it at the purchaser's own expense.
- E. If Contractor requests in writing that other special insurance be included in the property insurance policies provided under this Paragraph 5.06, Owner shall, if possible, include such insurance, and the cost thereof will be charged to Contractor by appropriate Change Order. Prior to commencement of the Work at the Site, Owner shall in writing advise Contractor whether or not such other insurance has been procured by Owner.

#### 5.07 *Waiver of Rights*

- A. Owner and Contractor intend that all policies purchased in accordance with Paragraph 5.06 will protect Owner, Contractor, Subcontractors, and Engineer, and all other individuals or entities identified in the Supplementary Conditions as loss payees (and the officers, directors, members, partners, employees, agents, consultants, and subcontractors of each and any of them) in such

policies and will provide primary coverage for all losses and damages caused by the perils or causes of loss covered thereby. All such policies shall contain provisions to the effect that in the event of payment of any loss or damage the insurers will have no rights of recovery against any of the insureds or loss payees thereunder. Owner and Contractor waive all rights against each other and their respective officers, directors, members, partners, employees, agents, consultants and subcontractors of each and any of them for all losses and damages caused by, arising out of or resulting from any of the perils or causes of loss covered by such policies and any other property insurance applicable to the Work; and, in addition, waive all such rights against Subcontractors and Engineer, and all other individuals or entities identified in the Supplementary Conditions as loss payees (and the officers, directors, members, partners, employees, agents, consultants, and subcontractors of each and any of them) under such policies for losses and damages so caused. None of the above waivers shall extend to the rights that any party making such waiver may have to the proceeds of insurance held by Owner as trustee or otherwise payable under any policy so issued.

- B. Owner waives all rights against Contractor, Subcontractors, and Engineer, and the officers, directors, members, partners, employees, agents, consultants and subcontractors of each and any of them for:
  - 1. loss due to business interruption, loss of use, or other consequential loss extending beyond direct physical loss or damage to Owner's property or the Work caused by, arising out of, or resulting from fire or other perils whether or not insured by Owner; and
  - 2. loss or damage to the completed Project or part thereof caused by, arising out of, or resulting from fire or other insured peril or cause of loss covered by any property insurance maintained on the completed Project or part thereof by Owner during partial utilization pursuant to Paragraph 14.05, after Substantial Completion pursuant to Paragraph 14.04, or after final payment pursuant to Paragraph 14.07.
- C. Any insurance policy maintained by Owner covering any loss, damage or consequential loss referred to in Paragraph 5.07.B shall contain provisions to the effect that in the event of payment of any such loss, damage, or consequential loss, the insurers will have no rights of recovery against Contractor, Subcontractors, or Engineer, and the officers, directors, members, partners, employees, agents, consultants and subcontractors of each and any of them.

#### 5.08 *Receipt and Application of Insurance Proceeds*

- A. Any insured loss under the policies of insurance required by Paragraph 5.06 will be adjusted with Owner and made payable to Owner as fiduciary for the loss payees, as their interests may appear, subject to the requirements of any applicable mortgage clause and of Paragraph 5.08.B. Owner shall deposit in a separate account any money so received and shall distribute it in accordance with such agreement as the parties in interest may reach. If no other special agreement is reached, the damaged Work shall be repaired or replaced, the moneys so received applied on account thereof, and the Work and the cost thereof covered by an appropriate Change Order.
- B. Owner as fiduciary shall have power to adjust and settle any loss with the insurers unless one of the parties in interest shall object in writing within 15 days after the occurrence of loss to Owner's exercise of this power. If such objection be made, Owner as fiduciary shall make settlement with the insurers in accordance with such agreement as the parties in interest may

reach. If no such agreement among the parties in interest is reached, Owner as fiduciary shall adjust and settle the loss with the insurers and, if required in writing by any party in interest, Owner as fiduciary shall give bond for the proper performance of such duties.

5.09 *Acceptance of Bonds and Insurance; Option to Replace*

- A. If either Owner or Contractor has any objection to the coverage afforded by or other provisions of the bonds or insurance required to be purchased and maintained by the other party in accordance with Article 5 on the basis of non-conformance with the Contract Documents, the objecting party shall so notify the other party in writing within 10 days after receipt of the certificates (or other evidence requested) required by Paragraph 2.01.B. Owner and Contractor shall each provide to the other such additional information in respect of insurance provided as the other may reasonably request. If either party does not purchase or maintain all of the bonds and insurance required of such party by the Contract Documents, such party shall notify the other party in writing of such failure to purchase prior to the start of the Work, or of such failure to maintain prior to any change in the required coverage. Without prejudice to any other right or remedy, the other party may elect to obtain equivalent bonds or insurance to protect such other party's interests at the expense of the party who was required to provide such coverage, and a Change Order shall be issued to adjust the Contract Price accordingly.

5.10 *Partial Utilization, Acknowledgment of Property Insurer*

- A. If Owner finds it necessary to occupy or use a portion or portions of the Work prior to Substantial Completion of all the Work as provided in Paragraph 14.05, no such use or occupancy shall commence before the insurers providing the property insurance pursuant to Paragraph 5.06 have acknowledged notice thereof and in writing effected any changes in coverage necessitated thereby. The insurers providing the property insurance shall consent by endorsement on the policy or policies, but the property insurance shall not be canceled or permitted to lapse on account of any such partial use or occupancy.

**ARTICLE 6 – CONTRACTOR'S RESPONSIBILITIES**

6.01 *Supervision and Superintendence*

- A. Contractor shall supervise, inspect, and direct the Work competently and efficiently, devoting such attention thereto and applying such skills and expertise as may be necessary to perform the Work in accordance with the Contract Documents. Contractor shall be solely responsible for the means, methods, techniques, sequences, and procedures of construction. Contractor shall not be responsible for the negligence of Owner or Engineer in the design or specification of a specific means, method, technique, sequence, or procedure of construction which is shown or indicated in and expressly required by the Contract Documents.
- B. At all times during the progress of the Work, Contractor shall assign a competent resident superintendent who shall not be replaced without written notice to Owner and Engineer except under extraordinary circumstances.

## 6.02 *Labor; Working Hours*

- A. Contractor shall provide competent, suitably qualified personnel to survey and lay out the Work and perform construction as required by the Contract Documents. Contractor shall at all times maintain good discipline and order at the Site.
- B. Except as otherwise required for the safety or protection of persons or the Work or property at the Site or adjacent thereto, and except as otherwise stated in the Contract Documents, all Work at the Site shall be performed during regular working hours. Contractor will not permit the performance of Work on a Saturday, Sunday, or any legal holiday without Owner's written consent (which will not be unreasonably withheld) given after prior written notice to Engineer.

## 6.03 *Services, Materials, and Equipment*

- A. Unless otherwise specified in the Contract Documents, Contractor shall provide and assume full responsibility for all services, materials, equipment, labor, transportation, construction equipment and machinery, tools, appliances, fuel, power, light, heat, telephone, water, sanitary facilities, temporary facilities, and all other facilities and incidentals necessary for the performance, testing, start-up, and completion of the Work.
- B. All materials and equipment incorporated into the Work shall be as specified or, if not specified, shall be of good quality and new, except as otherwise provided in the Contract Documents. All special warranties and guarantees required by the Specifications shall expressly run to the benefit of Owner. If required by Engineer, Contractor shall furnish satisfactory evidence (including reports of required tests) as to the source, kind, and quality of materials and equipment.
- C. All materials and equipment shall be stored, applied, installed, connected, erected, protected, used, cleaned, and conditioned in accordance with instructions of the applicable Supplier, except as otherwise may be provided in the Contract Documents.

## 6.04 *Progress Schedule*

- A. Contractor shall adhere to the Progress Schedule established in accordance with Paragraph 2.07 as it may be adjusted from time to time as provided below.
  - 1. Contractor shall submit to Engineer for acceptance (to the extent indicated in Paragraph 2.07) proposed adjustments in the Progress Schedule that will not result in changing the Contract Times. Such adjustments will comply with any provisions of the General Requirements applicable thereto.
  - 2. Proposed adjustments in the Progress Schedule that will change the Contract Times shall be submitted in accordance with the requirements of Article 12. Adjustments in Contract Times may only be made by a Change Order.

## 6.05 *Substitutes and "Or-Equals"*

- A. Whenever an item of material or equipment is specified or described in the Contract Documents by using the name of a proprietary item or the name of a particular Supplier, the specification or description is intended to establish the type, function, appearance, and quality required. Unless the specification or description contains or is followed by words reading that no like, equivalent,

or "or-equal" item or no substitution is permitted, other items of material or equipment or material or equipment of other Suppliers may be submitted to Engineer for review under the circumstances described below.

1. *"Or-Equal" Items:* If in Engineer's sole discretion an item of material or equipment proposed by Contractor is functionally equal to that named and sufficiently similar so that no change in related Work will be required, it may be considered by Engineer as an "or-equal" item, in which case review and approval of the proposed item may, in Engineer's sole discretion, be accomplished without compliance with some or all of the requirements for approval of proposed substitute items. For the purposes of this Paragraph 6.05.A.1, a proposed item of material or equipment will be considered functionally equal to an item so named if:

a. in the exercise of reasonable judgment Engineer determines that:

- 1) it is at least equal in materials of construction, quality, durability, appearance, strength, and design characteristics;
- 2) it will reliably perform at least equally well the function and achieve the results imposed by the design concept of the completed Project as a functioning whole; and
- 3) it has a proven record of performance and availability of responsive service.

b. Contractor certifies that, if approved and incorporated into the Work:

- 1) there will be no increase in cost to the Owner or increase in Contract Times; and
- 2) it will conform substantially to the detailed requirements of the item named in the Contract Documents.

2. *Substitute Items:*

a. If in Engineer's sole discretion an item of material or equipment proposed by Contractor does not qualify as an "or-equal" item under Paragraph 6.05.A.1, it will be considered a proposed substitute item.

b. Contractor shall submit sufficient information as provided below to allow Engineer to determine if the item of material or equipment proposed is essentially equivalent to that named and an acceptable substitute therefor. Requests for review of proposed substitute items of material or equipment will not be accepted by Engineer from anyone other than Contractor.

c. The requirements for review by Engineer will be as set forth in Paragraph 6.05.A.2.d, as supplemented by the General Requirements, and as Engineer may decide is appropriate under the circumstances.

d. Contractor shall make written application to Engineer for review of a proposed substitute item of material or equipment that Contractor seeks to furnish or use. The application:

- 1) shall certify that the proposed substitute item will:

- a) perform adequately the functions and achieve the results called for by the general design,
  - b) be similar in substance to that specified, and
  - c) be suited to the same use as that specified;
- 2) will state:
- a) the extent, if any, to which the use of the proposed substitute item will prejudice Contractor's achievement of Substantial Completion on time,
  - b) whether use of the proposed substitute item in the Work will require a change in any of the Contract Documents (or in the provisions of any other direct contract with Owner for other work on the Project) to adapt the design to the proposed substitute item, and
  - c) whether incorporation or use of the proposed substitute item in connection with the Work is subject to payment of any license fee or royalty;
- 3) will identify:
- a) all variations of the proposed substitute item from that specified, and
  - b) available engineering, sales, maintenance, repair, and replacement services; and
- 4) shall contain an itemized estimate of all costs or credits that will result directly or indirectly from use of such substitute item, including costs of redesign and claims of other contractors affected by any resulting change.

B. *Substitute Construction Methods or Procedures:* If a specific means, method, technique, sequence, or procedure of construction is expressly required by the Contract Documents, Contractor may furnish or utilize a substitute means, method, technique, sequence, or procedure of construction approved by Engineer. Contractor shall submit sufficient information to allow Engineer, in Engineer's sole discretion, to determine that the substitute proposed is equivalent to that expressly called for by the Contract Documents. The requirements for review by Engineer will be similar to those provided in Paragraph 6.05.A.2.

C. *Engineer's Evaluation:* Engineer will be allowed a reasonable time within which to evaluate each proposal or submittal made pursuant to Paragraphs 6.05.A and 6.05.B. Engineer may require Contractor to furnish additional data about the proposed substitute item. Engineer will be the sole judge of acceptability. No "or equal" or substitute will be ordered, installed or utilized until Engineer's review is complete, which will be evidenced by a Change Order in the case of a substitute and an approved Shop Drawing for an "or equal." Engineer will advise Contractor in writing of any negative determination.

D. *Special Guarantee:* Owner may require Contractor to furnish at Contractor's expense a special performance guarantee or other surety with respect to any substitute.

- E. *Engineer's Cost Reimbursement*: Engineer will record Engineer's costs in evaluating a substitute proposed or submitted by Contractor pursuant to Paragraphs 6.05.A.2 and 6.05.B. Whether or not Engineer approves a substitute so proposed or submitted by Contractor, Contractor shall reimburse Owner for the reasonable charges of Engineer for evaluating each such proposed substitute. Contractor shall also reimburse Owner for the reasonable charges of Engineer for making changes in the Contract Documents (or in the provisions of any other direct contract with Owner) resulting from the acceptance of each proposed substitute.
- F. *Contractor's Expense*: Contractor shall provide all data in support of any proposed substitute or "or-equal" at Contractor's expense.

6.06 *Concerning Subcontractors, Suppliers, and Others*

- A. Contractor shall not employ any Subcontractor, Supplier, or other individual or entity (including those acceptable to Owner as indicated in Paragraph 6.06.B), whether initially or as a replacement, against whom Owner may have reasonable objection. Contractor shall not be required to employ any Subcontractor, Supplier, or other individual or entity to furnish or perform any of the Work against whom Contractor has reasonable objection.
- B. If the Supplementary Conditions require the identity of certain Subcontractors, Suppliers, or other individuals or entities to be submitted to Owner in advance for acceptance by Owner by a specified date prior to the Effective Date of the Agreement, and if Contractor has submitted a list thereof in accordance with the Supplementary Conditions, Owner's acceptance (either in writing or by failing to make written objection thereto by the date indicated for acceptance or objection in the Bidding Documents or the Contract Documents) of any such Subcontractor, Supplier, or other individual or entity so identified may be revoked on the basis of reasonable objection after due investigation. Contractor shall submit an acceptable replacement for the rejected Subcontractor, Supplier, or other individual or entity, and the Contract Price will be adjusted by the difference in the cost occasioned by such replacement, and an appropriate Change Order will be issued. No acceptance by Owner of any such Subcontractor, Supplier, or other individual or entity, whether initially or as a replacement, shall constitute a waiver of any right of Owner or Engineer to reject defective Work.
- C. Contractor shall be fully responsible to Owner and Engineer for all acts and omissions of the Subcontractors, Suppliers, and other individuals or entities performing or furnishing any of the Work just as Contractor is responsible for Contractor's own acts and omissions. Nothing in the Contract Documents:
  - 1. shall create for the benefit of any such Subcontractor, Supplier, or other individual or entity any contractual relationship between Owner or Engineer and any such Subcontractor, Supplier or other individual or entity; nor
  - 2. shall create any obligation on the part of Owner or Engineer to pay or to see to the payment of any moneys due any such Subcontractor, Supplier, or other individual or entity except as may otherwise be required by Laws and Regulations.
- D. Contractor shall be solely responsible for scheduling and coordinating the Work of Subcontractors, Suppliers, and other individuals or entities performing or furnishing any of the Work under a direct or indirect contract with Contractor.

- E. Contractor shall require all Subcontractors, Suppliers, and such other individuals or entities performing or furnishing any of the Work to communicate with Engineer through Contractor.
- F. The divisions and sections of the Specifications and the identifications of any Drawings shall not control Contractor in dividing the Work among Subcontractors or Suppliers or delineating the Work to be performed by any specific trade.
- G. All Work performed for Contractor by a Subcontractor or Supplier will be pursuant to an appropriate agreement between Contractor and the Subcontractor or Supplier which specifically binds the Subcontractor or Supplier to the applicable terms and conditions of the Contract Documents for the benefit of Owner and Engineer. Whenever any such agreement is with a Subcontractor or Supplier who is listed as a loss payee on the property insurance provided in Paragraph 5.06, the agreement between the Contractor and the Subcontractor or Supplier will contain provisions whereby the Subcontractor or Supplier waives all rights against Owner, Contractor, Engineer, and all other individuals or entities identified in the Supplementary Conditions to be listed as insureds or loss payees (and the officers, directors, members, partners, employees, agents, consultants, and subcontractors of each and any of them) for all losses and damages caused by, arising out of, relating to, or resulting from any of the perils or causes of loss covered by such policies and any other property insurance applicable to the Work. If the insurers on any such policies require separate waiver forms to be signed by any Subcontractor or Supplier, Contractor will obtain the same.

#### 6.07 *Patent Fees and Royalties*

- A. Contractor shall pay all license fees and royalties and assume all costs incident to the use in the performance of the Work or the incorporation in the Work of any invention, design, process, product, or device which is the subject of patent rights or copyrights held by others. If a particular invention, design, process, product, or device is specified in the Contract Documents for use in the performance of the Work and if, to the actual knowledge of Owner or Engineer, its use is subject to patent rights or copyrights calling for the payment of any license fee or royalty to others, the existence of such rights shall be disclosed by Owner in the Contract Documents.
- B. To the fullest extent permitted by Laws and Regulations, Owner shall indemnify and hold harmless Contractor, and its officers, directors, members, partners, employees, agents, consultants, and subcontractors from and against all claims, costs, losses, and damages (including but not limited to all fees and charges of engineers, architects, attorneys, and other professionals, and all court or arbitration or other dispute resolution costs) arising out of or relating to any infringement of patent rights or copyrights incident to the use in the performance of the Work or resulting from the incorporation in the Work of any invention, design, process, product, or device specified in the Contract Documents, but not identified as being subject to payment of any license fee or royalty to others required by patent rights or copyrights.
- C. To the fullest extent permitted by Laws and Regulations, Contractor shall indemnify and hold harmless Owner and Engineer, and the officers, directors, members, partners, employees, agents, consultants and subcontractors of each and any of them from and against all claims, costs, losses, and damages (including but not limited to all fees and charges of engineers, architects, attorneys, and other professionals and all court or arbitration or other dispute resolution costs) arising out of or relating to any infringement of patent rights or copyrights incident to the use in the

performance of the Work or resulting from the incorporation in the Work of any invention, design, process, product, or device not specified in the Contract Documents.

6.08 *Permits*

- A. Unless otherwise provided in the Supplementary Conditions, Contractor shall obtain and pay for all construction permits and licenses. Owner shall assist Contractor, when necessary, in obtaining such permits and licenses. Contractor shall pay all governmental charges and inspection fees necessary for the prosecution of the Work which are applicable at the time of opening of Bids, or, if there are no Bids, on the Effective Date of the Agreement. Owner shall pay all charges of utility owners for connections for providing permanent service to the Work.

6.09 *Laws and Regulations*

- A. Contractor shall give all notices required by and shall comply with all Laws and Regulations applicable to the performance of the Work. Except where otherwise expressly required by applicable Laws and Regulations, neither Owner nor Engineer shall be responsible for monitoring Contractor's compliance with any Laws or Regulations.
- B. If Contractor performs any Work knowing or having reason to know that it is contrary to Laws or Regulations, Contractor shall bear all claims, costs, losses, and damages (including but not limited to all fees and charges of engineers, architects, attorneys, and other professionals and all court or arbitration or other dispute resolution costs) arising out of or relating to such Work. However, it shall not be Contractor's responsibility to make certain that the Specifications and Drawings are in accordance with Laws and Regulations, but this shall not relieve Contractor of Contractor's obligations under Paragraph 3.03.
- C. Changes in Laws or Regulations not known at the time of opening of Bids (or, on the Effective Date of the Agreement if there were no Bids) having an effect on the cost or time of performance of the Work shall be the subject of an adjustment in Contract Price or Contract Times. If Owner and Contractor are unable to agree on entitlement to or on the amount or extent, if any, of any such adjustment, a Claim may be made therefor as provided in Paragraph 10.05.

6.10 *Taxes*

- A. Contractor shall pay all sales, consumer, use, and other similar taxes required to be paid by Contractor in accordance with the Laws and Regulations of the place of the Project which are applicable during the performance of the Work.

6.11 *Use of Site and Other Areas*

A. *Limitation on Use of Site and Other Areas:*

- 1. Contractor shall confine construction equipment, the storage of materials and equipment, and the operations of workers to the Site and other areas permitted by Laws and Regulations, and shall not unreasonably encumber the Site and other areas with construction equipment or other materials or equipment. Contractor shall assume full responsibility for any damage to any such land or area, or to the owner or occupant thereof, or of any adjacent land or areas resulting from the performance of the Work.

2. Should any claim be made by any such owner or occupant because of the performance of the Work, Contractor shall promptly settle with such other party by negotiation or otherwise resolve the claim by arbitration or other dispute resolution proceeding or at law.
3. To the fullest extent permitted by Laws and Regulations, Contractor shall indemnify and hold harmless Owner and Engineer, and the officers, directors, members, partners, employees, agents, consultants and subcontractors of each and any of them from and against all claims, costs, losses, and damages (including but not limited to all fees and charges of engineers, architects, attorneys, and other professionals and all court or arbitration or other dispute resolution costs) arising out of or relating to any claim or action, legal or equitable, brought by any such owner or occupant against Owner, Engineer, or any other party indemnified hereunder to the extent caused by or based upon Contractor's performance of the Work.

- B. *Removal of Debris During Performance of the Work:* During the progress of the Work Contractor shall keep the Site and other areas free from accumulations of waste materials, rubbish, and other debris. Removal and disposal of such waste materials, rubbish, and other debris shall conform to applicable Laws and Regulations.
- C. *Cleaning:* Prior to Substantial Completion of the Work Contractor shall clean the Site and the Work and make it ready for utilization by Owner. At the completion of the Work Contractor shall remove from the Site all tools, appliances, construction equipment and machinery, and surplus materials and shall restore to original condition all property not designated for alteration by the Contract Documents.
- D. *Loading Structures:* Contractor shall not load nor permit any part of any structure to be loaded in any manner that will endanger the structure, nor shall Contractor subject any part of the Work or adjacent property to stresses or pressures that will endanger it.

#### 6.12 *Record Documents*

- A. Contractor shall maintain in a safe place at the Site one record copy of all Drawings, Specifications, Addenda, Change Orders, Work Change Directives, Field Orders, and written interpretations and clarifications in good order and annotated to show changes made during construction. These record documents together with all approved Samples and a counterpart of all approved Shop Drawings will be available to Engineer for reference. Upon completion of the Work, these record documents, Samples, and Shop Drawings will be delivered to Engineer for Owner.

#### 6.13 *Safety and Protection*

- A. Contractor shall be solely responsible for initiating, maintaining and supervising all safety precautions and programs in connection with the Work. Such responsibility does not relieve Subcontractors of their responsibility for the safety of persons or property in the performance of their work, nor for compliance with applicable safety Laws and Regulations. Contractor shall take all necessary precautions for the safety of, and shall provide the necessary protection to prevent damage, injury or loss to:

1. all persons on the Site or who may be affected by the Work;

2. all the Work and materials and equipment to be incorporated therein, whether in storage on or off the Site; and
  3. other property at the Site or adjacent thereto, including trees, shrubs, lawns, walks, pavements, roadways, structures, utilities, and Underground Facilities not designated for removal, relocation, or replacement in the course of construction.
- B. Contractor shall comply with all applicable Laws and Regulations relating to the safety of persons or property, or to the protection of persons or property from damage, injury, or loss; and shall erect and maintain all necessary safeguards for such safety and protection. Contractor shall notify owners of adjacent property and of Underground Facilities and other utility owners when prosecution of the Work may affect them, and shall cooperate with them in the protection, removal, relocation, and replacement of their property.
- C. Contractor shall comply with the applicable requirements of Owner's safety programs, if any. The Supplementary Conditions identify any Owner's safety programs that are applicable to the Work.
- D. Contractor shall inform Owner and Engineer of the specific requirements of Contractor's safety program with which Owner's and Engineer's employees and representatives must comply while at the Site.
- E. All damage, injury, or loss to any property referred to in Paragraph 6.13.A.2 or 6.13.A.3 caused, directly or indirectly, in whole or in part, by Contractor, any Subcontractor, Supplier, or any other individual or entity directly or indirectly employed by any of them to perform any of the Work, or anyone for whose acts any of them may be liable, shall be remedied by Contractor (except damage or loss attributable to the fault of Drawings or Specifications or to the acts or omissions of Owner or Engineer or anyone employed by any of them, or anyone for whose acts any of them may be liable, and not attributable, directly or indirectly, in whole or in part, to the fault or negligence of Contractor or any Subcontractor, Supplier, or other individual or entity directly or indirectly employed by any of them).
- F. Contractor's duties and responsibilities for safety and for protection of the Work shall continue until such time as all the Work is completed and Engineer has issued a notice to Owner and Contractor in accordance with Paragraph 14.07.B that the Work is acceptable (except as otherwise expressly provided in connection with Substantial Completion).

#### 6.14 *Safety Representative*

- A. Contractor shall designate a qualified and experienced safety representative at the Site whose duties and responsibilities shall be the prevention of accidents and the maintaining and supervising of safety precautions and programs.

#### 6.15 *Hazard Communication Programs*

- A. Contractor shall be responsible for coordinating any exchange of material safety data sheets or other hazard communication information required to be made available to or exchanged between or among employers at the Site in accordance with Laws or Regulations.

## 6.16 *Emergencies*

- A. In emergencies affecting the safety or protection of persons or the Work or property at the Site or adjacent thereto, Contractor is obligated to act to prevent threatened damage, injury, or loss. Contractor shall give Engineer prompt written notice if Contractor believes that any significant changes in the Work or variations from the Contract Documents have been caused thereby or are required as a result thereof. If Engineer determines that a change in the Contract Documents is required because of the action taken by Contractor in response to such an emergency, a Work Change Directive or Change Order will be issued.

## 6.17 *Shop Drawings and Samples*

- A. Contractor shall submit Shop Drawings and Samples to Engineer for review and approval in accordance with the accepted Schedule of Submittals (as required by Paragraph 2.07). Each submittal will be identified as Engineer may require.

### 1. *Shop Drawings:*

- a. Submit number of copies specified in the General Requirements.
- b. Data shown on the Shop Drawings will be complete with respect to quantities, dimensions, specified performance and design criteria, materials, and similar data to show Engineer the services, materials, and equipment Contractor proposes to provide and to enable Engineer to review the information for the limited purposes required by Paragraph 6.17.D.

### 2. *Samples:*

- a. Submit number of Samples specified in the Specifications.
- b. Clearly identify each Sample as to material, Supplier, pertinent data such as catalog numbers, the use for which intended and other data as Engineer may require to enable Engineer to review the submittal for the limited purposes required by Paragraph 6.17.D.

- B. Where a Shop Drawing or Sample is required by the Contract Documents or the Schedule of Submittals, any related Work performed prior to Engineer's review and approval of the pertinent submittal will be at the sole expense and responsibility of Contractor.

### C. *Submittal Procedures:*

1. Before submitting each Shop Drawing or Sample, Contractor shall have:

- a. reviewed and coordinated each Shop Drawing or Sample with other Shop Drawings and Samples and with the requirements of the Work and the Contract Documents;
- b. determined and verified all field measurements, quantities, dimensions, specified performance and design criteria, installation requirements, materials, catalog numbers, and similar information with respect thereto;

- c. determined and verified the suitability of all materials offered with respect to the indicated application, fabrication, shipping, handling, storage, assembly, and installation pertaining to the performance of the Work; and
  - d. determined and verified all information relative to Contractor's responsibilities for means, methods, techniques, sequences, and procedures of construction, and safety precautions and programs incident thereto.
2. Each submittal shall bear a stamp or specific written certification that Contractor has satisfied Contractor's obligations under the Contract Documents with respect to Contractor's review and approval of that submittal.
  3. With each submittal, Contractor shall give Engineer specific written notice of any variations that the Shop Drawing or Sample may have from the requirements of the Contract Documents. This notice shall be both a written communication separate from the Shop Drawings or Sample submittal; and, in addition, by a specific notation made on each Shop Drawing or Sample submitted to Engineer for review and approval of each such variation.

*D. Engineer's Review:*

1. Engineer will provide timely review of Shop Drawings and Samples in accordance with the Schedule of Submittals acceptable to Engineer. Engineer's review and approval will be only to determine if the items covered by the submittals will, after installation or incorporation in the Work, conform to the information given in the Contract Documents and be compatible with the design concept of the completed Project as a functioning whole as indicated by the Contract Documents.
2. Engineer's review and approval will not extend to means, methods, techniques, sequences, or procedures of construction (except where a particular means, method, technique, sequence, or procedure of construction is specifically and expressly called for by the Contract Documents) or to safety precautions or programs incident thereto. The review and approval of a separate item as such will not indicate approval of the assembly in which the item functions.
3. Engineer's review and approval shall not relieve Contractor from responsibility for any variation from the requirements of the Contract Documents unless Contractor has complied with the requirements of Paragraph 6.17.C.3 and Engineer has given written approval of each such variation by specific written notation thereof incorporated in or accompanying the Shop Drawing or Sample. Engineer's review and approval shall not relieve Contractor from responsibility for complying with the requirements of Paragraph 6.17.C.1.

*E. Resubmittal Procedures:*

1. Contractor shall make corrections required by Engineer and shall return the required number of corrected copies of Shop Drawings and submit, as required, new Samples for review and approval. Contractor shall direct specific attention in writing to revisions other than the corrections called for by Engineer on previous submittals.

6.18 *Continuing the Work*

- A. Contractor shall carry on the Work and adhere to the Progress Schedule during all disputes or disagreements with Owner. No Work shall be delayed or postponed pending resolution of any disputes or disagreements, except as permitted by Paragraph 15.04 or as Owner and Contractor may otherwise agree in writing.

6.19 *Contractor's General Warranty and Guarantee*

- A. Contractor warrants and guarantees to Owner that all Work will be in accordance with the Contract Documents and will not be defective. Engineer and its officers, directors, members, partners, employees, agents, consultants, and subcontractors shall be entitled to rely on representation of Contractor's warranty and guarantee.
- B. Contractor's warranty and guarantee hereunder excludes defects or damage caused by:
1. abuse, modification, or improper maintenance or operation by persons other than Contractor, Subcontractors, Suppliers, or any other individual or entity for whom Contractor is responsible; or
  2. normal wear and tear under normal usage.
- C. Contractor's obligation to perform and complete the Work in accordance with the Contract Documents shall be absolute. None of the following will constitute an acceptance of Work that is not in accordance with the Contract Documents or a release of Contractor's obligation to perform the Work in accordance with the Contract Documents:
1. observations by Engineer;
  2. recommendation by Engineer or payment by Owner of any progress or final payment;
  3. the issuance of a certificate of Substantial Completion by Engineer or any payment related thereto by Owner;
  4. use or occupancy of the Work or any part thereof by Owner;
  5. any review and approval of a Shop Drawing or Sample submittal or the issuance of a notice of acceptability by Engineer;
  6. any inspection, test, or approval by others; or
  7. any correction of defective Work by Owner.

6.20 *Indemnification*

- A. To the fullest extent permitted by Laws and Regulations, Contractor shall indemnify and hold harmless Owner and Engineer, and the officers, directors, members, partners, employees, agents, consultants and subcontractors of each and any of them from and against all claims, costs, losses, and damages (including but not limited to all fees and charges of engineers, architects, attorneys, and other professionals and all court or arbitration or other dispute resolution costs) arising out of

or relating to the performance of the Work, provided that any such claim, cost, loss, or damage is attributable to bodily injury, sickness, disease, or death, or to injury to or destruction of tangible property (other than the Work itself), including the loss of use resulting therefrom but only to the extent caused by any negligent act or omission of Contractor, any Subcontractor, any Supplier, or any individual or entity directly or indirectly employed by any of them to perform any of the Work or anyone for whose acts any of them may be liable .

- B. In any and all claims against Owner or Engineer or any of their officers, directors, members, partners, employees, agents, consultants, or subcontractors by any employee (or the survivor or personal representative of such employee) of Contractor, any Subcontractor, any Supplier, or any individual or entity directly or indirectly employed by any of them to perform any of the Work, or anyone for whose acts any of them may be liable, the indemnification obligation under Paragraph 6.20.A shall not be limited in any way by any limitation on the amount or type of damages, compensation, or benefits payable by or for Contractor or any such Subcontractor, Supplier, or other individual or entity under workers' compensation acts, disability benefit acts, or other employee benefit acts.
- C. The indemnification obligations of Contractor under Paragraph 6.20.A shall not extend to the liability of Engineer and Engineer's officers, directors, members, partners, employees, agents, consultants and subcontractors arising out of:
  - 1. the preparation or approval of, or the failure to prepare or approve maps, Drawings, opinions, reports, surveys, Change Orders, designs, or Specifications; or
  - 2. giving directions or instructions, or failing to give them, if that is the primary cause of the injury or damage.

#### 6.21 *Delegation of Professional Design Services*

- A. Contractor will not be required to provide professional design services unless such services are specifically required by the Contract Documents for a portion of the Work or unless such services are required to carry out Contractor's responsibilities for construction means, methods, techniques, sequences and procedures. Contractor shall not be required to provide professional services in violation of applicable law.
- B. If professional design services or certifications by a design professional related to systems, materials or equipment are specifically required of Contractor by the Contract Documents, Owner and Engineer will specify all performance and design criteria that such services must satisfy. Contractor shall cause such services or certifications to be provided by a properly licensed professional, whose signature and seal shall appear on all drawings, calculations, specifications, certifications, Shop Drawings and other submittals prepared by such professional. Shop Drawings and other submittals related to the Work designed or certified by such professional, if prepared by others, shall bear such professional's written approval when submitted to Engineer.
- C. Owner and Engineer shall be entitled to rely upon the adequacy, accuracy and completeness of the services, certifications or approvals performed by such design professionals, provided Owner and Engineer have specified to Contractor all performance and design criteria that such services must satisfy.

- D. Pursuant to this Paragraph 6.21, Engineer's review and approval of design calculations and design drawings will be only for the limited purpose of checking for conformance with performance and design criteria given and the design concept expressed in the Contract Documents. Engineer's review and approval of Shop Drawings and other submittals (except design calculations and design drawings) will be only for the purpose stated in Paragraph 6.17.D.1.
- E. Contractor shall not be responsible for the adequacy of the performance or design criteria required by the Contract Documents.

## **ARTICLE 7 – OTHER WORK AT THE SITE**

### **7.01 *Related Work at Site***

- A. Owner may perform other work related to the Project at the Site with Owner's employees, or through other direct contracts therefor, or have other work performed by utility owners. If such other work is not noted in the Contract Documents, then:
  - 1. written notice thereof will be given to Contractor prior to starting any such other work; and
  - 2. if Owner and Contractor are unable to agree on entitlement to or on the amount or extent, if any, of any adjustment in the Contract Price or Contract Times that should be allowed as a result of such other work, a Claim may be made therefor as provided in Paragraph 10.05.
- B. Contractor shall afford each other contractor who is a party to such a direct contract, each utility owner, and Owner, if Owner is performing other work with Owner's employees, proper and safe access to the Site, provide a reasonable opportunity for the introduction and storage of materials and equipment and the execution of such other work, and properly coordinate the Work with theirs. Contractor shall do all cutting, fitting, and patching of the Work that may be required to properly connect or otherwise make its several parts come together and properly integrate with such other work. Contractor shall not endanger any work of others by cutting, excavating, or otherwise altering such work; provided, however, that Contractor may cut or alter others' work with the written consent of Engineer and the others whose work will be affected. The duties and responsibilities of Contractor under this Paragraph are for the benefit of such utility owners and other contractors to the extent that there are comparable provisions for the benefit of Contractor in said direct contracts between Owner and such utility owners and other contractors.
- C. If the proper execution or results of any part of Contractor's Work depends upon work performed by others under this Article 7, Contractor shall inspect such other work and promptly report to Engineer in writing any delays, defects, or deficiencies in such other work that render it unavailable or unsuitable for the proper execution and results of Contractor's Work. Contractor's failure to so report will constitute an acceptance of such other work as fit and proper for integration with Contractor's Work except for latent defects and deficiencies in such other work.

### **7.02 *Coordination***

- A. If Owner intends to contract with others for the performance of other work on the Project at the Site, the following will be set forth in Supplementary Conditions:

1. the individual or entity who will have authority and responsibility for coordination of the activities among the various contractors will be identified;
  2. the specific matters to be covered by such authority and responsibility will be itemized; and
  3. the extent of such authority and responsibilities will be provided.
- B. Unless otherwise provided in the Supplementary Conditions, Owner shall have sole authority and responsibility for such coordination.

### 7.03 *Legal Relationships*

- A. Paragraphs 7.01.A and 7.02 are not applicable for utilities not under the control of Owner.
- B. Each other direct contract of Owner under Paragraph 7.01.A shall provide that the other contractor is liable to Owner and Contractor for the reasonable direct delay and disruption costs incurred by Contractor as a result of the other contractor's wrongful actions or inactions.
- C. Contractor shall be liable to Owner and any other contractor under direct contract to Owner for the reasonable direct delay and disruption costs incurred by such other contractor as a result of Contractor's wrongful action or inactions.

## **ARTICLE 8 – OWNER'S RESPONSIBILITIES**

### 8.01 *Communications to Contractor*

- A. Except as otherwise provided in these General Conditions, Owner shall issue all communications to Contractor through Engineer.

### 8.02 *Replacement of Engineer*

- A. In case of termination of the employment of Engineer, Owner shall appoint an engineer to whom Contractor makes no reasonable objection, whose status under the Contract Documents shall be that of the former Engineer.

### 8.03 *Furnish Data*

- A. Owner shall promptly furnish the data required of Owner under the Contract Documents.

### 8.04 *Pay When Due*

- A. Owner shall make payments to Contractor when they are due as provided in Paragraphs 14.02.C and 14.07.C.

### 8.05 *Lands and Easements; Reports and Tests*

- A. Owner's duties with respect to providing lands and easements and providing engineering surveys to establish reference points are set forth in Paragraphs 4.01 and 4.05. Paragraph 4.02 refers to Owner's identifying and making available to Contractor copies of reports of explorations and

tests of subsurface conditions and drawings of physical conditions relating to existing surface or subsurface structures at the Site.

8.06 *Insurance*

A. Owner's responsibilities, if any, with respect to purchasing and maintaining liability and property insurance are set forth in Article 5.

8.07 *Change Orders*

A. Owner is obligated to execute Change Orders as indicated in Paragraph 10.03.

8.08 *Inspections, Tests, and Approvals*

A. Owner's responsibility with respect to certain inspections, tests, and approvals is set forth in Paragraph 13.03.B.

8.09 *Limitations on Owner's Responsibilities*

A. The Owner shall not supervise, direct, or have control or authority over, nor be responsible for, Contractor's means, methods, techniques, sequences, or procedures of construction, or the safety precautions and programs incident thereto, or for any failure of Contractor to comply with Laws and Regulations applicable to the performance of the Work. Owner will not be responsible for Contractor's failure to perform the Work in accordance with the Contract Documents.

8.10 *Undisclosed Hazardous Environmental Condition*

A. Owner's responsibility in respect to an undisclosed Hazardous Environmental Condition is set forth in Paragraph 4.06.

8.11 *Evidence of Financial Arrangements*

A. Upon request of Contractor, Owner shall furnish Contractor reasonable evidence that financial arrangements have been made to satisfy Owner's obligations under the Contract Documents.

8.12 *Compliance with Safety Program*

A. While at the Site, Owner's employees and representatives shall comply with the specific applicable requirements of Contractor's safety programs of which Owner has been informed pursuant to Paragraph 6.13.D.

**ARTICLE 9 – ENGINEER'S STATUS DURING CONSTRUCTION**

9.01 *Owner's Representative*

A. Engineer will be Owner's representative during the construction period. The duties and responsibilities and the limitations of authority of Engineer as Owner's representative during construction are set forth in the Contract Documents.

## 9.02 *Visits to Site*

- A. Engineer will make visits to the Site at intervals appropriate to the various stages of construction as Engineer deems necessary in order to observe as an experienced and qualified design professional the progress that has been made and the quality of the various aspects of Contractor's executed Work. Based on information obtained during such visits and observations, Engineer, for the benefit of Owner, will determine, in general, if the Work is proceeding in accordance with the Contract Documents. Engineer will not be required to make exhaustive or continuous inspections on the Site to check the quality or quantity of the Work. Engineer's efforts will be directed toward providing for Owner a greater degree of confidence that the completed Work will conform generally to the Contract Documents. On the basis of such visits and observations, Engineer will keep Owner informed of the progress of the Work and will endeavor to guard Owner against defective Work.
- B. Engineer's visits and observations are subject to all the limitations on Engineer's authority and responsibility set forth in Paragraph 9.09. Particularly, but without limitation, during or as a result of Engineer's visits or observations of Contractor's Work, Engineer will not supervise, direct, control, or have authority over or be responsible for Contractor's means, methods, techniques, sequences, or procedures of construction, or the safety precautions and programs incident thereto, or for any failure of Contractor to comply with Laws and Regulations applicable to the performance of the Work.

## 9.03 *Project Representative*

- A. If Owner and Engineer agree, Engineer will furnish a Resident Project Representative to assist Engineer in providing more extensive observation of the Work. The authority and responsibilities of any such Resident Project Representative and assistants will be as provided in the Supplementary Conditions, and limitations on the responsibilities thereof will be as provided in Paragraph 9.09. If Owner designates another representative or agent to represent Owner at the Site who is not Engineer's consultant, agent or employee, the responsibilities and authority and limitations thereon of such other individual or entity will be as provided in the Supplementary Conditions.

## 9.04 *Authorized Variations in Work*

- A. Engineer may authorize minor variations in the Work from the requirements of the Contract Documents which do not involve an adjustment in the Contract Price or the Contract Times and are compatible with the design concept of the completed Project as a functioning whole as indicated by the Contract Documents. These may be accomplished by a Field Order and will be binding on Owner and also on Contractor, who shall perform the Work involved promptly. If Owner or Contractor believes that a Field Order justifies an adjustment in the Contract Price or Contract Times, or both, and the parties are unable to agree on entitlement to or on the amount or extent, if any, of any such adjustment, a Claim may be made therefor as provided in Paragraph 10.05.

## 9.05 *Rejecting Defective Work*

- A. Engineer will have authority to reject Work which Engineer believes to be defective, or that Engineer believes will not produce a completed Project that conforms to the Contract Documents

or that will prejudice the integrity of the design concept of the completed Project as a functioning whole as indicated by the Contract Documents. Engineer will also have authority to require special inspection or testing of the Work as provided in Paragraph 13.04, whether or not the Work is fabricated, installed, or completed.

9.06 *Shop Drawings, Change Orders and Payments*

- A. In connection with Engineer's authority, and limitations thereof, as to Shop Drawings and Samples, see Paragraph 6.17.
- B. In connection with Engineer's authority, and limitations thereof, as to design calculations and design drawings submitted in response to a delegation of professional design services, if any, see Paragraph 6.21.
- C. In connection with Engineer's authority as to Change Orders, see Articles 10, 11, and 12.
- D. In connection with Engineer's authority as to Applications for Payment, see Article 14.

9.07 *Determinations for Unit Price Work*

- A. Engineer will determine the actual quantities and classifications of Unit Price Work performed by Contractor. Engineer will review with Contractor the Engineer's preliminary determinations on such matters before rendering a written decision thereon (by recommendation of an Application for Payment or otherwise). Engineer's written decision thereon will be final and binding (except as modified by Engineer to reflect changed factual conditions or more accurate data) upon Owner and Contractor, subject to the provisions of Paragraph 10.05.

9.08 *Decisions on Requirements of Contract Documents and Acceptability of Work*

- A. Engineer will be the initial interpreter of the requirements of the Contract Documents and judge of the acceptability of the Work thereunder. All matters in question and other matters between Owner and Contractor arising prior to the date final payment is due relating to the acceptability of the Work, and the interpretation of the requirements of the Contract Documents pertaining to the performance of the Work, will be referred initially to Engineer in writing within 30 days of the event giving rise to the question.
- B. Engineer will, with reasonable promptness, render a written decision on the issue referred. If Owner or Contractor believes that any such decision entitles them to an adjustment in the Contract Price or Contract Times or both, a Claim may be made under Paragraph 10.05. The date of Engineer's decision shall be the date of the event giving rise to the issues referenced for the purposes of Paragraph 10.05.B.
- C. Engineer's written decision on the issue referred will be final and binding on Owner and Contractor, subject to the provisions of Paragraph 10.05.
- D. When functioning as interpreter and judge under this Paragraph 9.08, Engineer will not show partiality to Owner or Contractor and will not be liable in connection with any interpretation or decision rendered in good faith in such capacity.

9.09 *Limitations on Engineer's Authority and Responsibilities*

- A. Neither Engineer's authority or responsibility under this Article 9 or under any other provision of the Contract Documents nor any decision made by Engineer in good faith either to exercise or not exercise such authority or responsibility or the undertaking, exercise, or performance of any authority or responsibility by Engineer shall create, impose, or give rise to any duty in contract, tort, or otherwise owed by Engineer to Contractor, any Subcontractor, any Supplier, any other individual or entity, or to any surety for or employee or agent of any of them.
- B. Engineer will not supervise, direct, control, or have authority over or be responsible for Contractor's means, methods, techniques, sequences, or procedures of construction, or the safety precautions and programs incident thereto, or for any failure of Contractor to comply with Laws and Regulations applicable to the performance of the Work. Engineer will not be responsible for Contractor's failure to perform the Work in accordance with the Contract Documents.
- C. Engineer will not be responsible for the acts or omissions of Contractor or of any Subcontractor, any Supplier, or of any other individual or entity performing any of the Work.
- D. Engineer's review of the final Application for Payment and accompanying documentation and all maintenance and operating instructions, schedules, guarantees, bonds, certificates of inspection, tests and approvals, and other documentation required to be delivered by Paragraph 14.07.A will only be to determine generally that their content complies with the requirements of, and in the case of certificates of inspections, tests, and approvals that the results certified indicate compliance with, the Contract Documents.
- E. The limitations upon authority and responsibility set forth in this Paragraph 9.09 shall also apply to the Resident Project Representative, if any, and assistants, if any.

9.10 *Compliance with Safety Program*

- A. While at the Site, Engineer's employees and representatives shall comply with the specific applicable requirements of Contractor's safety programs of which Engineer has been informed pursuant to Paragraph 6.13.D.

**ARTICLE 10 – CHANGES IN THE WORK; CLAIMS**

10.01 *Authorized Changes in the Work*

- A. Without invalidating the Contract and without notice to any surety, Owner may, at any time or from time to time, order additions, deletions, or revisions in the Work by a Change Order, or a Work Change Directive. Upon receipt of any such document, Contractor shall promptly proceed with the Work involved which will be performed under the applicable conditions of the Contract Documents (except as otherwise specifically provided).
- B. If Owner and Contractor are unable to agree on entitlement to, or on the amount or extent, if any, of an adjustment in the Contract Price or Contract Times, or both, that should be allowed as a result of a Work Change Directive, a Claim may be made therefor as provided in Paragraph 10.05.

#### 10.02 *Unauthorized Changes in the Work*

- A. Contractor shall not be entitled to an increase in the Contract Price or an extension of the Contract Times with respect to any work performed that is not required by the Contract Documents as amended, modified, or supplemented as provided in Paragraph 3.04, except in the case of an emergency as provided in Paragraph 6.16 or in the case of uncovering Work as provided in Paragraph 13.04.D.

#### 10.03 *Execution of Change Orders*

- A. Owner and Contractor shall execute appropriate Change Orders recommended by Engineer covering:
  - 1. changes in the Work which are: (i) ordered by Owner pursuant to Paragraph 10.01.A, (ii) required because of acceptance of defective Work under Paragraph 13.08.A or Owner's correction of defective Work under Paragraph 13.09, or (iii) agreed to by the parties;
  - 2. changes in the Contract Price or Contract Times which are agreed to by the parties, including any undisputed sum or amount of time for Work actually performed in accordance with a Work Change Directive; and
  - 3. changes in the Contract Price or Contract Times which embody the substance of any written decision rendered by Engineer pursuant to Paragraph 10.05; provided that, in lieu of executing any such Change Order, an appeal may be taken from any such decision in accordance with the provisions of the Contract Documents and applicable Laws and Regulations, but during any such appeal, Contractor shall carry on the Work and adhere to the Progress Schedule as provided in Paragraph 6.18.A.

#### 10.04 *Notification to Surety*

- A. If the provisions of any bond require notice to be given to a surety of any change affecting the general scope of the Work or the provisions of the Contract Documents (including, but not limited to, Contract Price or Contract Times), the giving of any such notice will be Contractor's responsibility. The amount of each applicable bond will be adjusted to reflect the effect of any such change.

#### 10.05 *Claims*

- A. *Engineer's Decision Required:* All Claims, except those waived pursuant to Paragraph 14.09, shall be referred to the Engineer for decision. A decision by Engineer shall be required as a condition precedent to any exercise by Owner or Contractor of any rights or remedies either may otherwise have under the Contract Documents or by Laws and Regulations in respect of such Claims.
- B. *Notice:* Written notice stating the general nature of each Claim shall be delivered by the claimant to Engineer and the other party to the Contract promptly (but in no event later than 30 days) after the start of the event giving rise thereto. The responsibility to substantiate a Claim shall rest with the party making the Claim. Notice of the amount or extent of the Claim, with supporting data shall be delivered to the Engineer and the other party to the Contract within 60 days after the

start of such event (unless Engineer allows additional time for claimant to submit additional or more accurate data in support of such Claim). A Claim for an adjustment in Contract Price shall be prepared in accordance with the provisions of Paragraph 12.01.B. A Claim for an adjustment in Contract Times shall be prepared in accordance with the provisions of Paragraph 12.02.B. Each Claim shall be accompanied by claimant's written statement that the adjustment claimed is the entire adjustment to which the claimant believes it is entitled as a result of said event. The opposing party shall submit any response to Engineer and the claimant within 30 days after receipt of the claimant's last submittal (unless Engineer allows additional time).

- C. *Engineer's Action:* Engineer will review each Claim and, within 30 days after receipt of the last submittal of the claimant or the last submittal of the opposing party, if any, take one of the following actions in writing:
1. deny the Claim in whole or in part;
  2. approve the Claim; or
  3. notify the parties that the Engineer is unable to resolve the Claim if, in the Engineer's sole discretion, it would be inappropriate for the Engineer to do so. For purposes of further resolution of the Claim, such notice shall be deemed a denial.
- D. In the event that Engineer does not take action on a Claim within said 30 days, the Claim shall be deemed denied.
- E. Engineer's written action under Paragraph 10.05.C or denial pursuant to Paragraphs 10.05.C.3 or 10.05.D will be final and binding upon Owner and Contractor, unless Owner or Contractor invoke the dispute resolution procedure set forth in Article 16 within 30 days of such action or denial.
- F. No Claim for an adjustment in Contract Price or Contract Times will be valid if not submitted in accordance with this Paragraph 10.05.

## **ARTICLE 11 – COST OF THE WORK; ALLOWANCES; UNIT PRICE WORK**

### **11.01 *Cost of the Work***

- A. *Costs Included:* The term Cost of the Work means the sum of all costs, except those excluded in Paragraph 11.01.B, necessarily incurred and paid by Contractor in the proper performance of the Work. When the value of any Work covered by a Change Order or when a Claim for an adjustment in Contract Price is determined on the basis of Cost of the Work, the costs to be reimbursed to Contractor will be only those additional or incremental costs required because of the change in the Work or because of the event giving rise to the Claim. Except as otherwise may be agreed to in writing by Owner, such costs shall be in amounts no higher than those prevailing in the locality of the Project, shall not include any of the costs itemized in Paragraph 11.01.B, and shall include only the following items:
1. Payroll costs for employees in the direct employ of Contractor in the performance of the Work under schedules of job classifications agreed upon by Owner and Contractor. Such employees shall include, without limitation, superintendents, foremen, and other personnel

employed full time on the Work. Payroll costs for employees not employed full time on the Work shall be apportioned on the basis of their time spent on the Work. Payroll costs shall include, but not be limited to, salaries and wages plus the cost of fringe benefits, which shall include social security contributions, unemployment, excise, and payroll taxes, workers' compensation, health and retirement benefits, bonuses, sick leave, vacation and holiday pay applicable thereto. The expenses of performing Work outside of regular working hours, on Saturday, Sunday, or legal holidays, shall be included in the above to the extent authorized by Owner.

2. Cost of all materials and equipment furnished and incorporated in the Work, including costs of transportation and storage thereof, and Suppliers' field services required in connection therewith. All cash discounts shall accrue to Contractor unless Owner deposits funds with Contractor with which to make payments, in which case the cash discounts shall accrue to Owner. All trade discounts, rebates and refunds and returns from sale of surplus materials and equipment shall accrue to Owner, and Contractor shall make provisions so that they may be obtained.
3. Payments made by Contractor to Subcontractors for Work performed by Subcontractors. If required by Owner, Contractor shall obtain competitive bids from subcontractors acceptable to Owner and Contractor and shall deliver such bids to Owner, who will then determine, with the advice of Engineer, which bids, if any, will be acceptable. If any subcontract provides that the Subcontractor is to be paid on the basis of Cost of the Work plus a fee, the Subcontractor's Cost of the Work and fee shall be determined in the same manner as Contractor's Cost of the Work and fee as provided in this Paragraph 11.01.
4. Costs of special consultants (including but not limited to engineers, architects, testing laboratories, surveyors, attorneys, and accountants) employed for services specifically related to the Work.
5. Supplemental costs including the following:
  - a. The proportion of necessary transportation, travel, and subsistence expenses of Contractor's employees incurred in discharge of duties connected with the Work.
  - b. Cost, including transportation and maintenance, of all materials, supplies, equipment, machinery, appliances, office, and temporary facilities at the Site, and hand tools not owned by the workers, which are consumed in the performance of the Work, and cost, less market value, of such items used but not consumed which remain the property of Contractor.
  - c. Rentals of all construction equipment and machinery, and the parts thereof whether rented from Contractor or others in accordance with rental agreements approved by Owner with the advice of Engineer, and the costs of transportation, loading, unloading, assembly, dismantling, and removal thereof. All such costs shall be in accordance with the terms of said rental agreements. The rental of any such equipment, machinery, or parts shall cease when the use thereof is no longer necessary for the Work.
  - d. Sales, consumer, use, and other similar taxes related to the Work, and for which Contractor is liable, as imposed by Laws and Regulations.

- e. Deposits lost for causes other than negligence of Contractor, any Subcontractor, or anyone directly or indirectly employed by any of them or for whose acts any of them may be liable, and royalty payments and fees for permits and licenses.
- f. Losses and damages (and related expenses) caused by damage to the Work, not compensated by insurance or otherwise, sustained by Contractor in connection with the performance of the Work (except losses and damages within the deductible amounts of property insurance established in accordance with Paragraph 5.06.D), provided such losses and damages have resulted from causes other than the negligence of Contractor, any Subcontractor, or anyone directly or indirectly employed by any of them or for whose acts any of them may be liable. Such losses shall include settlements made with the written consent and approval of Owner. No such losses, damages, and expenses shall be included in the Cost of the Work for the purpose of determining Contractor's fee.
- g. The cost of utilities, fuel, and sanitary facilities at the Site.
- h. Minor expenses such as telegrams, long distance telephone calls, telephone service at the Site, express and courier services, and similar petty cash items in connection with the Work.
- i. The costs of premiums for all bonds and insurance Contractor is required by the Contract Documents to purchase and maintain.

B. *Costs Excluded:* The term Cost of the Work shall not include any of the following items:

1. Payroll costs and other compensation of Contractor's officers, executives, principals (of partnerships and sole proprietorships), general managers, safety managers, engineers, architects, estimators, attorneys, auditors, accountants, purchasing and contracting agents, expeditors, timekeepers, clerks, and other personnel employed by Contractor, whether at the Site or in Contractor's principal or branch office for general administration of the Work and not specifically included in the agreed upon schedule of job classifications referred to in Paragraph 11.01.A.1 or specifically covered by Paragraph 11.01.A.4, all of which are to be considered administrative costs covered by the Contractor's fee.
2. Expenses of Contractor's principal and branch offices other than Contractor's office at the Site.
3. Any part of Contractor's capital expenses, including interest on Contractor's capital employed for the Work and charges against Contractor for delinquent payments.
4. Costs due to the negligence of Contractor, any Subcontractor, or anyone directly or indirectly employed by any of them or for whose acts any of them may be liable, including but not limited to, the correction of defective Work, disposal of materials or equipment wrongly supplied, and making good any damage to property.
5. Other overhead or general expense costs of any kind and the costs of any item not specifically and expressly included in Paragraphs 11.01.A.

- C. *Contractor's Fee:* When all the Work is performed on the basis of cost-plus, Contractor's fee shall be determined as set forth in the Agreement. When the value of any Work covered by a Change Order or when a Claim for an adjustment in Contract Price is determined on the basis of Cost of the Work, Contractor's fee shall be determined as set forth in Paragraph 12.01.C.
- D. *Documentation:* Whenever the Cost of the Work for any purpose is to be determined pursuant to Paragraphs 11.01.A and 11.01.B, Contractor will establish and maintain records thereof in accordance with generally accepted accounting practices and submit in a form acceptable to Engineer an itemized cost breakdown together with supporting data.

## 11.02 Allowances

- A. It is understood that Contractor has included in the Contract Price all allowances so named in the Contract Documents and shall cause the Work so covered to be performed for such sums and by such persons or entities as may be acceptable to Owner and Engineer.
- B. *Cash Allowances:*
  - 1. Contractor agrees that:
    - a. the cash allowances include the cost to Contractor (less any applicable trade discounts) of materials and equipment required by the allowances to be delivered at the Site, and all applicable taxes; and
    - b. Contractor's costs for unloading and handling on the Site, labor, installation, overhead, profit, and other expenses contemplated for the cash allowances have been included in the Contract Price and not in the allowances, and no demand for additional payment on account of any of the foregoing will be valid.
- C. *Contingency Allowance:*
  - 1. Contractor agrees that a contingency allowance, if any, is for the sole use of Owner to cover unanticipated costs.
- D. Prior to final payment, an appropriate Change Order will be issued as recommended by Engineer to reflect actual amounts due Contractor on account of Work covered by allowances, and the Contract Price shall be correspondingly adjusted.

## 11.03 Unit Price Work

- A. Where the Contract Documents provide that all or part of the Work is to be Unit Price Work, initially the Contract Price will be deemed to include for all Unit Price Work an amount equal to the sum of the unit price for each separately identified item of Unit Price Work times the estimated quantity of each item as indicated in the Agreement.
- B. The estimated quantities of items of Unit Price Work are not guaranteed and are solely for the purpose of comparison of Bids and determining an initial Contract Price. Determinations of the actual quantities and classifications of Unit Price Work performed by Contractor will be made by Engineer subject to the provisions of Paragraph 9.07.

- C. Each unit price will be deemed to include an amount considered by Contractor to be adequate to cover Contractor's overhead and profit for each separately identified item.
- D. Owner or Contractor may make a Claim for an adjustment in the Contract Price in accordance with Paragraph 10.05 if:
  - 1. the quantity of any item of Unit Price Work performed by Contractor differs materially and significantly from the estimated quantity of such item indicated in the Agreement; and
  - 2. there is no corresponding adjustment with respect to any other item of Work; and
  - 3. Contractor believes that Contractor is entitled to an increase in Contract Price as a result of having incurred additional expense or Owner believes that Owner is entitled to a decrease in Contract Price and the parties are unable to agree as to the amount of any such increase or decrease.

## **ARTICLE 12 – CHANGE OF CONTRACT PRICE; CHANGE OF CONTRACT TIMES**

### **12.01 *Change of Contract Price***

- A. The Contract Price may only be changed by a Change Order. Any Claim for an adjustment in the Contract Price shall be based on written notice submitted by the party making the Claim to the Engineer and the other party to the Contract in accordance with the provisions of Paragraph 10.05.
- B. The value of any Work covered by a Change Order or of any Claim for an adjustment in the Contract Price will be determined as follows:
  - 1. where the Work involved is covered by unit prices contained in the Contract Documents, by application of such unit prices to the quantities of the items involved (subject to the provisions of Paragraph 11.03); or
  - 2. where the Work involved is not covered by unit prices contained in the Contract Documents, by a mutually agreed lump sum (which may include an allowance for overhead and profit not necessarily in accordance with Paragraph 12.01.C.2); or
  - 3. where the Work involved is not covered by unit prices contained in the Contract Documents and agreement to a lump sum is not reached under Paragraph 12.01.B.2, on the basis of the Cost of the Work (determined as provided in Paragraph 11.01) plus a Contractor's fee for overhead and profit (determined as provided in Paragraph 12.01.C).
- C. *Contractor's Fee:* The Contractor's fee for overhead and profit shall be determined as follows:
  - 1. a mutually acceptable fixed fee; or
  - 2. if a fixed fee is not agreed upon, then a fee based on the following percentages of the various portions of the Cost of the Work:
    - a. for costs incurred under Paragraphs 11.01.A.1 and 11.01.A.2, the Contractor's fee shall be 15 percent;

- b. for costs incurred under Paragraph 11.01.A.3, the Contractor's fee shall be five percent;
- c. where one or more tiers of subcontracts are on the basis of Cost of the Work plus a fee and no fixed fee is agreed upon, the intent of Paragraphs 12.01.C.2.a and 12.01.C.2.b is that the Subcontractor who actually performs the Work, at whatever tier, will be paid a fee of 15 percent of the costs incurred by such Subcontractor under Paragraphs 11.01.A.1 and 11.01.A.2 and that any higher tier Subcontractor and Contractor will each be paid a fee of five percent of the amount paid to the next lower tier Subcontractor;
- d. no fee shall be payable on the basis of costs itemized under Paragraphs 11.01.A.4, 11.01.A.5, and 11.01.B;
- e. the amount of credit to be allowed by Contractor to Owner for any change which results in a net decrease in cost will be the amount of the actual net decrease in cost plus a deduction in Contractor's fee by an amount equal to five percent of such net decrease; and
- f. when both additions and credits are involved in any one change, the adjustment in Contractor's fee shall be computed on the basis of the net change in accordance with Paragraphs 12.01.C.2.a through 12.01.C.2.e, inclusive.

#### 12.02 *Change of Contract Times*

- A. The Contract Times may only be changed by a Change Order. Any Claim for an adjustment in the Contract Times shall be based on written notice submitted by the party making the Claim to the Engineer and the other party to the Contract in accordance with the provisions of Paragraph 10.05.
- B. Any adjustment of the Contract Times covered by a Change Order or any Claim for an adjustment in the Contract Times will be determined in accordance with the provisions of this Article 12.

#### 12.03 *Delays*

- A. Where Contractor is prevented from completing any part of the Work within the Contract Times due to delay beyond the control of Contractor, the Contract Times will be extended in an amount equal to the time lost due to such delay if a Claim is made therefor as provided in Paragraph 12.02.A. Delays beyond the control of Contractor shall include, but not be limited to, acts or neglect by Owner, acts or neglect of utility owners or other contractors performing other work as contemplated by Article 7, fires, floods, epidemics, abnormal weather conditions, or acts of God.
- B. If Owner, Engineer, or other contractors or utility owners performing other work for Owner as contemplated by Article 7, or anyone for whom Owner is responsible, delays, disrupts, or interferes with the performance or progress of the Work, then Contractor shall be entitled to an equitable adjustment in the Contract Price or the Contract Times, or both. Contractor's entitlement to an adjustment of the Contract Times is conditioned on such adjustment being essential to Contractor's ability to complete the Work within the Contract Times.

- C. If Contractor is delayed in the performance or progress of the Work by fire, flood, epidemic, abnormal weather conditions, acts of God, acts or failures to act of utility owners not under the control of Owner, or other causes not the fault of and beyond control of Owner and Contractor, then Contractor shall be entitled to an equitable adjustment in Contract Times, if such adjustment is essential to Contractor's ability to complete the Work within the Contract Times. Such an adjustment shall be Contractor's sole and exclusive remedy for the delays described in this Paragraph 12.03.C.
- D. Owner, Engineer, and their officers, directors, members, partners, employees, agents, consultants, or subcontractors shall not be liable to Contractor for any claims, costs, losses, or damages (including but not limited to all fees and charges of engineers, architects, attorneys, and other professionals and all court or arbitration or other dispute resolution costs) sustained by Contractor on or in connection with any other project or anticipated project.
- E. Contractor shall not be entitled to an adjustment in Contract Price or Contract Times for delays within the control of Contractor. Delays attributable to and within the control of a Subcontractor or Supplier shall be deemed to be delays within the control of Contractor.

## **ARTICLE 13 – TESTS AND INSPECTIONS; CORRECTION, REMOVAL OR ACCEPTANCE OF DEFECTIVE WORK**

### *13.01 Notice of Defects*

- A. Prompt notice of all defective Work of which Owner or Engineer has actual knowledge will be given to Contractor. Defective Work may be rejected, corrected, or accepted as provided in this Article 13.

### *13.02 Access to Work*

- A. Owner, Engineer, their consultants and other representatives and personnel of Owner, independent testing laboratories, and governmental agencies with jurisdictional interests will have access to the Site and the Work at reasonable times for their observation, inspection, and testing. Contractor shall provide them proper and safe conditions for such access and advise them of Contractor's safety procedures and programs so that they may comply therewith as applicable.

### *13.03 Tests and Inspections*

- A. Contractor shall give Engineer timely notice of readiness of the Work for all required inspections, tests, or approvals and shall cooperate with inspection and testing personnel to facilitate required inspections or tests.
- B. Owner shall employ and pay for the services of an independent testing laboratory to perform all inspections, tests, or approvals required by the Contract Documents except:
  - 1. for inspections, tests, or approvals covered by Paragraphs 13.03.C and 13.03.D below;
  - 2. that costs incurred in connection with tests or inspections conducted pursuant to Paragraph 13.04.B shall be paid as provided in Paragraph 13.04.C; and
  - 3. as otherwise specifically provided in the Contract Documents.

- C. If Laws or Regulations of any public body having jurisdiction require any Work (or part thereof) specifically to be inspected, tested, or approved by an employee or other representative of such public body, Contractor shall assume full responsibility for arranging and obtaining such inspections, tests, or approvals, pay all costs in connection therewith, and furnish Engineer the required certificates of inspection or approval.
- D. Contractor shall be responsible for arranging and obtaining and shall pay all costs in connection with any inspections, tests, or approvals required for Owner's and Engineer's acceptance of materials or equipment to be incorporated in the Work; or acceptance of materials, mix designs, or equipment submitted for approval prior to Contractor's purchase thereof for incorporation in the Work. Such inspections, tests, or approvals shall be performed by organizations acceptable to Owner and Engineer.
- E. If any Work (or the work of others) that is to be inspected, tested, or approved is covered by Contractor without written concurrence of Engineer, Contractor shall, if requested by Engineer, uncover such Work for observation.
- F. Uncovering Work as provided in Paragraph 13.03.E shall be at Contractor's expense unless Contractor has given Engineer timely notice of Contractor's intention to cover the same and Engineer has not acted with reasonable promptness in response to such notice.

#### 13.04 *Uncovering Work*

- A. If any Work is covered contrary to the written request of Engineer, it must, if requested by Engineer, be uncovered for Engineer's observation and replaced at Contractor's expense.
- B. If Engineer considers it necessary or advisable that covered Work be observed by Engineer or inspected or tested by others, Contractor, at Engineer's request, shall uncover, expose, or otherwise make available for observation, inspection, or testing as Engineer may require, that portion of the Work in question, furnishing all necessary labor, material, and equipment.
- C. If it is found that the uncovered Work is defective, Contractor shall pay all claims, costs, losses, and damages (including but not limited to all fees and charges of engineers, architects, attorneys, and other professionals and all court or arbitration or other dispute resolution costs) arising out of or relating to such uncovering, exposure, observation, inspection, and testing, and of satisfactory replacement or reconstruction (including but not limited to all costs of repair or replacement of work of others); and Owner shall be entitled to an appropriate decrease in the Contract Price. If the parties are unable to agree as to the amount thereof, Owner may make a Claim therefor as provided in Paragraph 10.05.
- D. If the uncovered Work is not found to be defective, Contractor shall be allowed an increase in the Contract Price or an extension of the Contract Times, or both, directly attributable to such uncovering, exposure, observation, inspection, testing, replacement, and reconstruction. If the parties are unable to agree as to the amount or extent thereof, Contractor may make a Claim therefor as provided in Paragraph 10.05.

### 13.05 *Owner May Stop the Work*

- A. If the Work is defective, or Contractor fails to supply sufficient skilled workers or suitable materials or equipment, or fails to perform the Work in such a way that the completed Work will conform to the Contract Documents, Owner may order Contractor to stop the Work, or any portion thereof, until the cause for such order has been eliminated; however, this right of Owner to stop the Work shall not give rise to any duty on the part of Owner to exercise this right for the benefit of Contractor, any Subcontractor, any Supplier, any other individual or entity, or any surety for, or employee or agent of any of them.

### 13.06 *Correction or Removal of Defective Work*

- A. Promptly after receipt of written notice, Contractor shall correct all defective Work, whether or not fabricated, installed, or completed, or, if the Work has been rejected by Engineer, remove it from the Project and replace it with Work that is not defective. Contractor shall pay all claims, costs, losses, and damages (including but not limited to all fees and charges of engineers, architects, attorneys, and other professionals and all court or arbitration or other dispute resolution costs) arising out of or relating to such correction or removal (including but not limited to all costs of repair or replacement of work of others).
- B. When correcting defective Work under the terms of this Paragraph 13.06 or Paragraph 13.07, Contractor shall take no action that would void or otherwise impair Owner's special warranty and guarantee, if any, on said Work.

### 13.07 *Correction Period*

- A. If within one year after the date of Substantial Completion (or such longer period of time as may be prescribed by the terms of any applicable special guarantee required by the Contract Documents) or by any specific provision of the Contract Documents, any Work is found to be defective, or if the repair of any damages to the land or areas made available for Contractor's use by Owner or permitted by Laws and Regulations as contemplated in Paragraph 6.11.A is found to be defective, Contractor shall promptly, without cost to Owner and in accordance with Owner's written instructions:
  - 1. repair such defective land or areas; or
  - 2. correct such defective Work; or
  - 3. if the defective Work has been rejected by Owner, remove it from the Project and replace it with Work that is not defective, and
  - 4. satisfactorily correct or repair or remove and replace any damage to other Work, to the work of others or other land or areas resulting therefrom.
- B. If Contractor does not promptly comply with the terms of Owner's written instructions, or in an emergency where delay would cause serious risk of loss or damage, Owner may have the defective Work corrected or repaired or may have the rejected Work removed and replaced. All claims, costs, losses, and damages (including but not limited to all fees and charges of engineers, architects, attorneys, and other professionals and all court or arbitration or other dispute

resolution costs) arising out of or relating to such correction or repair or such removal and replacement (including but not limited to all costs of repair or replacement of work of others) will be paid by Contractor.

- C. In special circumstances where a particular item of equipment is placed in continuous service before Substantial Completion of all the Work, the correction period for that item may start to run from an earlier date if so provided in the Specifications.
- D. Where defective Work (and damage to other Work resulting therefrom) has been corrected or removed and replaced under this Paragraph 13.07, the correction period hereunder with respect to such Work will be extended for an additional period of one year after such correction or removal and replacement has been satisfactorily completed.
- E. Contractor's obligations under this Paragraph 13.07 are in addition to any other obligation or warranty. The provisions of this Paragraph 13.07 shall not be construed as a substitute for, or a waiver of, the provisions of any applicable statute of limitation or repose.

#### 13.08 *Acceptance of Defective Work*

- A. If, instead of requiring correction or removal and replacement of defective Work, Owner (and, prior to Engineer's recommendation of final payment, Engineer) prefers to accept it, Owner may do so. Contractor shall pay all claims, costs, losses, and damages (including but not limited to all fees and charges of engineers, architects, attorneys, and other professionals and all court or arbitration or other dispute resolution costs) attributable to Owner's evaluation of and determination to accept such defective Work (such costs to be approved by Engineer as to reasonableness) and for the diminished value of the Work to the extent not otherwise paid by Contractor pursuant to this sentence. If any such acceptance occurs prior to Engineer's recommendation of final payment, a Change Order will be issued incorporating the necessary revisions in the Contract Documents with respect to the Work, and Owner shall be entitled to an appropriate decrease in the Contract Price, reflecting the diminished value of Work so accepted. If the parties are unable to agree as to the amount thereof, Owner may make a Claim therefor as provided in Paragraph 10.05. If the acceptance occurs after such recommendation, an appropriate amount will be paid by Contractor to Owner.

#### 13.09 *Owner May Correct Defective Work*

- A. If Contractor fails within a reasonable time after written notice from Engineer to correct defective Work, or to remove and replace rejected Work as required by Engineer in accordance with Paragraph 13.06.A, or if Contractor fails to perform the Work in accordance with the Contract Documents, or if Contractor fails to comply with any other provision of the Contract Documents, Owner may, after seven days written notice to Contractor, correct, or remedy any such deficiency.
- B. In exercising the rights and remedies under this Paragraph 13.09, Owner shall proceed expeditiously. In connection with such corrective or remedial action, Owner may exclude Contractor from all or part of the Site, take possession of all or part of the Work and suspend Contractor's services related thereto, take possession of Contractor's tools, appliances, construction equipment and machinery at the Site, and incorporate in the Work all materials and equipment stored at the Site or for which Owner has paid Contractor but which are stored

elsewhere. Contractor shall allow Owner, Owner's representatives, agents and employees, Owner's other contractors, and Engineer and Engineer's consultants access to the Site to enable Owner to exercise the rights and remedies under this Paragraph.

- C. All claims, costs, losses, and damages (including but not limited to all fees and charges of engineers, architects, attorneys, and other professionals and all court or arbitration or other dispute resolution costs) incurred or sustained by Owner in exercising the rights and remedies under this Paragraph 13.09 will be charged against Contractor, and a Change Order will be issued incorporating the necessary revisions in the Contract Documents with respect to the Work; and Owner shall be entitled to an appropriate decrease in the Contract Price. If the parties are unable to agree as to the amount of the adjustment, Owner may make a Claim therefor as provided in Paragraph 10.05. Such claims, costs, losses and damages will include but not be limited to all costs of repair, or replacement of work of others destroyed or damaged by correction, removal, or replacement of Contractor's defective Work.
- D. Contractor shall not be allowed an extension of the Contract Times because of any delay in the performance of the Work attributable to the exercise by Owner of Owner's rights and remedies under this Paragraph 13.09.

## **ARTICLE 14 – PAYMENTS TO CONTRACTOR AND COMPLETION**

### *14.01 Schedule of Values*

- A. The Schedule of Values established as provided in Paragraph 2.07.A will serve as the basis for progress payments and will be incorporated into a form of Application for Payment acceptable to Engineer. Progress payments on account of Unit Price Work will be based on the number of units completed.

### *14.02 Progress Payments*

#### *A. Applications for Payments:*

1. At least 20 days before the date established in the Agreement for each progress payment (but not more often than once a month), Contractor shall submit to Engineer for review an Application for Payment filled out and signed by Contractor covering the Work completed as of the date of the Application and accompanied by such supporting documentation as is required by the Contract Documents. If payment is requested on the basis of materials and equipment not incorporated in the Work but delivered and suitably stored at the Site or at another location agreed to in writing, the Application for Payment shall also be accompanied by a bill of sale, invoice, or other documentation warranting that Owner has received the materials and equipment free and clear of all Liens and evidence that the materials and equipment are covered by appropriate property insurance or other arrangements to protect Owner's interest therein, all of which must be satisfactory to Owner.
2. Beginning with the second Application for Payment, each Application shall include an affidavit of Contractor stating that all previous progress payments received on account of the Work have been applied on account to discharge Contractor's legitimate obligations associated with prior Applications for Payment.

3. The amount of retainage with respect to progress payments will be as stipulated in the Agreement.

B. *Review of Applications:*

1. Engineer will, within 10 days after receipt of each Application for Payment, either indicate in writing a recommendation of payment and present the Application to Owner or return the Application to Contractor indicating in writing Engineer's reasons for refusing to recommend payment. In the latter case, Contractor may make the necessary corrections and resubmit the Application.
2. Engineer's recommendation of any payment requested in an Application for Payment will constitute a representation by Engineer to Owner, based on Engineer's observations of the executed Work as an experienced and qualified design professional, and on Engineer's review of the Application for Payment and the accompanying data and schedules, that to the best of Engineer's knowledge, information and belief:
  - a. the Work has progressed to the point indicated;
  - b. the quality of the Work is generally in accordance with the Contract Documents (subject to an evaluation of the Work as a functioning whole prior to or upon Substantial Completion, the results of any subsequent tests called for in the Contract Documents, a final determination of quantities and classifications for Unit Price Work under Paragraph 9.07, and any other qualifications stated in the recommendation); and
  - c. the conditions precedent to Contractor's being entitled to such payment appear to have been fulfilled in so far as it is Engineer's responsibility to observe the Work.
3. By recommending any such payment Engineer will not thereby be deemed to have represented that:
  - a. inspections made to check the quality or the quantity of the Work as it has been performed have been exhaustive, extended to every aspect of the Work in progress, or involved detailed inspections of the Work beyond the responsibilities specifically assigned to Engineer in the Contract Documents; or
  - b. there may not be other matters or issues between the parties that might entitle Contractor to be paid additionally by Owner or entitle Owner to withhold payment to Contractor.
4. Neither Engineer's review of Contractor's Work for the purposes of recommending payments nor Engineer's recommendation of any payment, including final payment, will impose responsibility on Engineer:
  - a. to supervise, direct, or control the Work, or
  - b. for the means, methods, techniques, sequences, or procedures of construction, or the safety precautions and programs incident thereto, or
  - c. for Contractor's failure to comply with Laws and Regulations applicable to Contractor's performance of the Work, or

- d. to make any examination to ascertain how or for what purposes Contractor has used the moneys paid on account of the Contract Price, or
  - e. to determine that title to any of the Work, materials, or equipment has passed to Owner free and clear of any Liens.
5. Engineer may refuse to recommend the whole or any part of any payment if, in Engineer's opinion, it would be incorrect to make the representations to Owner stated in Paragraph 14.02.B.2. Engineer may also refuse to recommend any such payment or, because of subsequently discovered evidence or the results of subsequent inspections or tests, revise or revoke any such payment recommendation previously made, to such extent as may be necessary in Engineer's opinion to protect Owner from loss because:
- a. the Work is defective, or completed Work has been damaged, requiring correction or replacement;
  - b. the Contract Price has been reduced by Change Orders;
  - c. Owner has been required to correct defective Work or complete Work in accordance with Paragraph 13.09; or
  - d. Engineer has actual knowledge of the occurrence of any of the events enumerated in Paragraph 15.02.A.

*C. Payment Becomes Due:*

- 1. Ten days after presentation of the Application for Payment to Owner with Engineer's recommendation, the amount recommended will (subject to the provisions of Paragraph 14.02.D) become due, and when due will be paid by Owner to Contractor.

*D. Reduction in Payment:*

- 1. Owner may refuse to make payment of the full amount recommended by Engineer because:
  - a. claims have been made against Owner on account of Contractor's performance or furnishing of the Work;
  - b. Liens have been filed in connection with the Work, except where Contractor has delivered a specific bond satisfactory to Owner to secure the satisfaction and discharge of such Liens;
  - c. there are other items entitling Owner to a set-off against the amount recommended; or
  - d. Owner has actual knowledge of the occurrence of any of the events enumerated in Paragraphs 14.02.B.5.a through 14.02.B.5.c or Paragraph 15.02.A.
- 2. If Owner refuses to make payment of the full amount recommended by Engineer, Owner will give Contractor immediate written notice (with a copy to Engineer) stating the reasons for such action and promptly pay Contractor any amount remaining after deduction of the amount so withheld. Owner shall promptly pay Contractor the amount so withheld, or any

adjustment thereto agreed to by Owner and Contractor, when Contractor remedies the reasons for such action.

3. Upon a subsequent determination that Owner's refusal of payment was not justified, the amount wrongfully withheld shall be treated as an amount due as determined by Paragraph 14.02.C.1 and subject to interest as provided in the Agreement.

#### 14.03 *Contractor's Warranty of Title*

- A. Contractor warrants and guarantees that title to all Work, materials, and equipment covered by any Application for Payment, whether incorporated in the Project or not, will pass to Owner no later than the time of payment free and clear of all Liens.

#### 14.04 *Substantial Completion*

- A. When Contractor considers the entire Work ready for its intended use Contractor shall notify Owner and Engineer in writing that the entire Work is substantially complete (except for items specifically listed by Contractor as incomplete) and request that Engineer issue a certificate of Substantial Completion.
- B. Promptly after Contractor's notification, Owner, Contractor, and Engineer shall make an inspection of the Work to determine the status of completion. If Engineer does not consider the Work substantially complete, Engineer will notify Contractor in writing giving the reasons therefor.
- C. If Engineer considers the Work substantially complete, Engineer will deliver to Owner a tentative certificate of Substantial Completion which shall fix the date of Substantial Completion. There shall be attached to the certificate a tentative list of items to be completed or corrected before final payment. Owner shall have seven days after receipt of the tentative certificate during which to make written objection to Engineer as to any provisions of the certificate or attached list. If, after considering such objections, Engineer concludes that the Work is not substantially complete, Engineer will, within 14 days after submission of the tentative certificate to Owner, notify Contractor in writing, stating the reasons therefor. If, after consideration of Owner's objections, Engineer considers the Work substantially complete, Engineer will, within said 14 days, execute and deliver to Owner and Contractor a definitive certificate of Substantial Completion (with a revised tentative list of items to be completed or corrected) reflecting such changes from the tentative certificate as Engineer believes justified after consideration of any objections from Owner.
- D. At the time of delivery of the tentative certificate of Substantial Completion, Engineer will deliver to Owner and Contractor a written recommendation as to division of responsibilities pending final payment between Owner and Contractor with respect to security, operation, safety, and protection of the Work, maintenance, heat, utilities, insurance, and warranties and guarantees. Unless Owner and Contractor agree otherwise in writing and so inform Engineer in writing prior to Engineer's issuing the definitive certificate of Substantial Completion, Engineer's aforesaid recommendation will be binding on Owner and Contractor until final payment.

- E. Owner shall have the right to exclude Contractor from the Site after the date of Substantial Completion subject to allowing Contractor reasonable access to remove its property and complete or correct items on the tentative list.

#### 14.05 *Partial Utilization*

- A. Prior to Substantial Completion of all the Work, Owner may use or occupy any substantially completed part of the Work which has specifically been identified in the Contract Documents, or which Owner, Engineer, and Contractor agree constitutes a separately functioning and usable part of the Work that can be used by Owner for its intended purpose without significant interference with Contractor's performance of the remainder of the Work, subject to the following conditions:
  - 1. Owner at any time may request Contractor in writing to permit Owner to use or occupy any such part of the Work which Owner believes to be ready for its intended use and substantially complete. If and when Contractor agrees that such part of the Work is substantially complete, Contractor, Owner, and Engineer will follow the procedures of Paragraph 14.04.A through D for that part of the Work.
  - 2. Contractor at any time may notify Owner and Engineer in writing that Contractor considers any such part of the Work ready for its intended use and substantially complete and request Engineer to issue a certificate of Substantial Completion for that part of the Work.
  - 3. Within a reasonable time after either such request, Owner, Contractor, and Engineer shall make an inspection of that part of the Work to determine its status of completion. If Engineer does not consider that part of the Work to be substantially complete, Engineer will notify Owner and Contractor in writing giving the reasons therefor. If Engineer considers that part of the Work to be substantially complete, the provisions of Paragraph 14.04 will apply with respect to certification of Substantial Completion of that part of the Work and the division of responsibility in respect thereof and access thereto.
  - 4. No use or occupancy or separate operation of part of the Work may occur prior to compliance with the requirements of Paragraph 5.10 regarding property insurance.

#### 14.06 *Final Inspection*

- A. Upon written notice from Contractor that the entire Work or an agreed portion thereof is complete, Engineer will promptly make a final inspection with Owner and Contractor and will notify Contractor in writing of all particulars in which this inspection reveals that the Work is incomplete or defective. Contractor shall immediately take such measures as are necessary to complete such Work or remedy such deficiencies.

## 14.07 *Final Payment*

### A. *Application for Payment:*

1. After Contractor has, in the opinion of Engineer, satisfactorily completed all corrections identified during the final inspection and has delivered, in accordance with the Contract Documents, all maintenance and operating instructions, schedules, guarantees, bonds, certificates or other evidence of insurance, certificates of inspection, marked-up record documents (as provided in Paragraph 6.12), and other documents, Contractor may make application for final payment following the procedure for progress payments.
2. The final Application for Payment shall be accompanied (except as previously delivered) by:
  - a. all documentation called for in the Contract Documents, including but not limited to the evidence of insurance required by Paragraph 5.04.B.6;
  - b. consent of the surety, if any, to final payment;
  - c. a list of all Claims against Owner that Contractor believes are unsettled; and
  - d. complete and legally effective releases or waivers (satisfactory to Owner) of all Lien rights arising out of or Liens filed in connection with the Work.
3. In lieu of the releases or waivers of Liens specified in Paragraph 14.07.A.2 and as approved by Owner, Contractor may furnish receipts or releases in full and an affidavit of Contractor that: (i) the releases and receipts include all labor, services, material, and equipment for which a Lien could be filed; and (ii) all payrolls, material and equipment bills, and other indebtedness connected with the Work for which Owner might in any way be responsible, or which might in any way result in liens or other burdens on Owner's property, have been paid or otherwise satisfied. If any Subcontractor or Supplier fails to furnish such a release or receipt in full, Contractor may furnish a bond or other collateral satisfactory to Owner to indemnify Owner against any Lien.

### B. *Engineer's Review of Application and Acceptance:*

1. If, on the basis of Engineer's observation of the Work during construction and final inspection, and Engineer's review of the final Application for Payment and accompanying documentation as required by the Contract Documents, Engineer is satisfied that the Work has been completed and Contractor's other obligations under the Contract Documents have been fulfilled, Engineer will, within ten days after receipt of the final Application for Payment, indicate in writing Engineer's recommendation of payment and present the Application for Payment to Owner for payment. At the same time Engineer will also give written notice to Owner and Contractor that the Work is acceptable subject to the provisions of Paragraph 14.09. Otherwise, Engineer will return the Application for Payment to Contractor, indicating in writing the reasons for refusing to recommend final payment, in which case Contractor shall make the necessary corrections and resubmit the Application for Payment.

### C. *Payment Becomes Due:*

1. Thirty days after the presentation to Owner of the Application for Payment and accompanying documentation, the amount recommended by Engineer, less any sum Owner is entitled to set off against Engineer's recommendation, including but not limited to liquidated damages, will become due and will be paid by Owner to Contractor.

#### 14.08 *Final Completion Delayed*

- A. If, through no fault of Contractor, final completion of the Work is significantly delayed, and if Engineer so confirms, Owner shall, upon receipt of Contractor's final Application for Payment (for Work fully completed and accepted) and recommendation of Engineer, and without terminating the Contract, make payment of the balance due for that portion of the Work fully completed and accepted. If the remaining balance to be held by Owner for Work not fully completed or corrected is less than the retainage stipulated in the Agreement, and if bonds have been furnished as required in Paragraph 5.01, the written consent of the surety to the payment of the balance due for that portion of the Work fully completed and accepted shall be submitted by Contractor to Engineer with the Application for such payment. Such payment shall be made under the terms and conditions governing final payment, except that it shall not constitute a waiver of Claims.

#### 14.09 *Waiver of Claims*

- A. The making and acceptance of final payment will constitute:
  1. a waiver of all Claims by Owner against Contractor, except Claims arising from unsettled Liens, from defective Work appearing after final inspection pursuant to Paragraph 14.06, from failure to comply with the Contract Documents or the terms of any special guarantees specified therein, or from Contractor's continuing obligations under the Contract Documents; and
  2. a waiver of all Claims by Contractor against Owner other than those previously made in accordance with the requirements herein and expressly acknowledged by Owner in writing as still unsettled.

### **ARTICLE 15 – SUSPENSION OF WORK AND TERMINATION**

#### 15.01 *Owner May Suspend Work*

- A. At any time and without cause, Owner may suspend the Work or any portion thereof for a period of not more than 90 consecutive days by notice in writing to Contractor and Engineer which will fix the date on which Work will be resumed. Contractor shall resume the Work on the date so fixed. Contractor shall be granted an adjustment in the Contract Price or an extension of the Contract Times, or both, directly attributable to any such suspension if Contractor makes a Claim therefor as provided in Paragraph 10.05.

#### 15.02 *Owner May Terminate for Cause*

- A. The occurrence of any one or more of the following events will justify termination for cause:
  1. Contractor's persistent failure to perform the Work in accordance with the Contract Documents (including, but not limited to, failure to supply sufficient skilled workers or

- suitable materials or equipment or failure to adhere to the Progress Schedule established under Paragraph 2.07 as adjusted from time to time pursuant to Paragraph 6.04);
2. Contractor's disregard of Laws or Regulations of any public body having jurisdiction;
  3. Contractor's repeated disregard of the authority of Engineer; or
  4. Contractor's violation in any substantial way of any provisions of the Contract Documents.
- B. If one or more of the events identified in Paragraph 15.02.A occur, Owner may, after giving Contractor (and surety) seven days written notice of its intent to terminate the services of Contractor:
1. exclude Contractor from the Site, and take possession of the Work and of all Contractor's tools, appliances, construction equipment, and machinery at the Site, and use the same to the full extent they could be used by Contractor (without liability to Contractor for trespass or conversion);
  2. incorporate in the Work all materials and equipment stored at the Site or for which Owner has paid Contractor but which are stored elsewhere; and
  3. complete the Work as Owner may deem expedient.
- C. If Owner proceeds as provided in Paragraph 15.02.B, Contractor shall not be entitled to receive any further payment until the Work is completed. If the unpaid balance of the Contract Price exceeds all claims, costs, losses, and damages (including but not limited to all fees and charges of engineers, architects, attorneys, and other professionals and all court or arbitration or other dispute resolution costs) sustained by Owner arising out of or relating to completing the Work, such excess will be paid to Contractor. If such claims, costs, losses, and damages exceed such unpaid balance, Contractor shall pay the difference to Owner. Such claims, costs, losses, and damages incurred by Owner will be reviewed by Engineer as to their reasonableness and, when so approved by Engineer, incorporated in a Change Order. When exercising any rights or remedies under this Paragraph, Owner shall not be required to obtain the lowest price for the Work performed.
- D. Notwithstanding Paragraphs 15.02.B and 15.02.C, Contractor's services will not be terminated if Contractor begins within seven days of receipt of notice of intent to terminate to correct its failure to perform and proceeds diligently to cure such failure within no more than 30 days of receipt of said notice.
- E. Where Contractor's services have been so terminated by Owner, the termination will not affect any rights or remedies of Owner against Contractor then existing or which may thereafter accrue. Any retention or payment of moneys due Contractor by Owner will not release Contractor from liability.
- F. If and to the extent that Contractor has provided a performance bond under the provisions of Paragraph 5.01.A, the termination procedures of that bond shall supersede the provisions of Paragraphs 15.02.B and 15.02.C.

### 15.03 *Owner May Terminate For Convenience*

- A. Upon seven days written notice to Contractor and Engineer, Owner may, without cause and without prejudice to any other right or remedy of Owner, terminate the Contract. In such case, Contractor shall be paid for (without duplication of any items):
1. completed and acceptable Work executed in accordance with the Contract Documents prior to the effective date of termination, including fair and reasonable sums for overhead and profit on such Work;
  2. expenses sustained prior to the effective date of termination in performing services and furnishing labor, materials, or equipment as required by the Contract Documents in connection with uncompleted Work, plus fair and reasonable sums for overhead and profit on such expenses;
  3. all claims, costs, losses, and damages (including but not limited to all fees and charges of engineers, architects, attorneys, and other professionals and all court or arbitration or other dispute resolution costs) incurred in settlement of terminated contracts with Subcontractors, Suppliers, and others; and
  4. reasonable expenses directly attributable to termination.
- B. Contractor shall not be paid on account of loss of anticipated profits or revenue or other economic loss arising out of or resulting from such termination.

### 15.04 *Contractor May Stop Work or Terminate*

- A. If, through no act or fault of Contractor, (i) the Work is suspended for more than 90 consecutive days by Owner or under an order of court or other public authority, or (ii) Engineer fails to act on any Application for Payment within 30 days after it is submitted, or (iii) Owner fails for 30 days to pay Contractor any sum finally determined to be due, then Contractor may, upon seven days written notice to Owner and Engineer, and provided Owner or Engineer do not remedy such suspension or failure within that time, terminate the Contract and recover from Owner payment on the same terms as provided in Paragraph 15.03.
- B. In lieu of terminating the Contract and without prejudice to any other right or remedy, if Engineer has failed to act on an Application for Payment within 30 days after it is submitted, or Owner has failed for 30 days to pay Contractor any sum finally determined to be due, Contractor may, seven days after written notice to Owner and Engineer, stop the Work until payment is made of all such amounts due Contractor, including interest thereon. The provisions of this Paragraph 15.04 are not intended to preclude Contractor from making a Claim under Paragraph 10.05 for an adjustment in Contract Price or Contract Times or otherwise for expenses or damage directly attributable to Contractor's stopping the Work as permitted by this Paragraph.

## **ARTICLE 16 – DISPUTE RESOLUTION**

### 16.01 *Methods and Procedures*

- A. Either Owner or Contractor may request mediation of any Claim submitted to Engineer for a decision under Paragraph 10.05 before such decision becomes final and binding. The mediation

will be governed by the Construction Industry Mediation Rules of the American Arbitration Association in effect as of the Effective Date of the Agreement. The request for mediation shall be submitted in writing to the American Arbitration Association and the other party to the Contract. Timely submission of the request shall stay the effect of Paragraph 10.05.E.

- B. Owner and Contractor shall participate in the mediation process in good faith. The process shall be concluded within 60 days of filing of the request. The date of termination of the mediation shall be determined by application of the mediation rules referenced above.
- C. If the Claim is not resolved by mediation, Engineer's action under Paragraph 10.05.C or a denial pursuant to Paragraphs 10.05.C.3 or 10.05.D shall become final and binding 30 days after termination of the mediation unless, within that time period, Owner or Contractor:
  - 1. elects in writing to invoke any dispute resolution process provided for in the Supplementary Conditions; or
  - 2. agrees with the other party to submit the Claim to another dispute resolution process; or
  - 3. gives written notice to the other party of the intent to submit the Claim to a court of competent jurisdiction.

## **ARTICLE 17 – MISCELLANEOUS**

### **17.01 *Giving Notice***

- A. Whenever any provision of the Contract Documents requires the giving of written notice, it will be deemed to have been validly given if:
  - 1. delivered in person to the individual or to a member of the firm or to an officer of the corporation for whom it is intended; or
  - 2. delivered at or sent by registered or certified mail, postage prepaid, to the last business address known to the giver of the notice.

### **17.02 *Computation of Times***

- A. When any period of time is referred to in the Contract Documents by days, it will be computed to exclude the first and include the last day of such period. If the last day of any such period falls on a Saturday or Sunday or on a day made a legal holiday by the law of the applicable jurisdiction, such day will be omitted from the computation.

### **17.03 *Cumulative Remedies***

- A. The duties and obligations imposed by these General Conditions and the rights and remedies available hereunder to the parties hereto are in addition to, and are not to be construed in any way as a limitation of, any rights and remedies available to any or all of them which are otherwise imposed or available by Laws or Regulations, by special warranty or guarantee, or by other provisions of the Contract Documents. The provisions of this Paragraph will be as effective as if repeated specifically in the Contract Documents in connection with each particular duty, obligation, right, and remedy to which they apply.

17.04 *Survival of Obligations*

- A. All representations, indemnifications, warranties, and guarantees made in, required by, or given in accordance with the Contract Documents, as well as all continuing obligations indicated in the Contract Documents, will survive final payment, completion, and acceptance of the Work or termination or completion of the Contract or termination of the services of Contractor.

17.05 *Controlling Law*

- A. This Contract is to be governed by the law of the state in which the Project is located.

17.06 *Headings*

- A. Article and paragraph headings are inserted for convenience only and do not constitute parts of these General Conditions.

\*

\*

\*

\*

**Blank Sheet**

\*

\*

\*